

Hong Kong Supplementary Character Set

Information Technology Services Department & Official Languages Agency

Government of the Hong Kong Special Administrative Region

September 1999

Table of Contents

Preface

Section 1 Overview

Section 2 Code Allocation of the HKSCS in Big-5

Section 3 Code Allocation of the HKSCS in ISO 10646

Annex I Lists of Characters in the GCCS Not Included in the HKSCS

Annex II List of Compatibility Points and Their Corresponding Characters in ISO 10646 v1.0

Annex III List of Compatibility Points and Their Corresponding Characters in ISO 10646 v2.0

Preface

Information stored in a computer is coded according to a pre-defined coding scheme. For information in Chinese, there are different coding schemes including “Big-5”, “GB 2312-80” and “ISO/IEC 10646-1:1993” (ISO 10646). A common shortcoming of these coding schemes is that they do not cover all characters in use in the Hong Kong Special Administrative Region (HKSAR). Among the characters not included in these schemes, many are unique to the HKSAR. Some of them are used in names of persons and places while some are used in Cantonese expressions. To be able to use such characters in a computer system, users need to assign internal codes for these characters in the user-defined area by themselves. This works well in stand-alone computers, but when computers are connected with each other, these user-defined characters may give rise to problems in communication and data exchange.

To facilitate electronic communication within the Government, a set of Chinese characters, the Government Common Character Set (GCCS), was developed in 1995. The release of the GCCS marked the first step in coordinating the use of user-defined Chinese characters within the Government and was well received by the public as a supplement to the standard character set of Big-5. This supplementary character set has recently been enhanced by the Government in collaboration with the newly established Chinese Language Interface Advisory Committee (CLIAC), which comprises representatives from academic institutions, language and linguistics associations and the IT and publishing industries. The enhanced character set includes characters collected from various sectors in the HKSAR and represents a common set for the community. It is thus named the Hong Kong Supplementary Character Set (HKSCS). There are two code allocation schemes for the HKSCS, one for Big-5 and the other for ISO 10646. The HKSCS for Big-5 is in effect the updated version of the GCCS.

One of the initiatives under the "Digital 21" IT Strategy announced by the Information Technology and Broadcasting Bureau in November 1998 is to develop an open and common Chinese language interface in the HKSAR for users who prefer to communicate electronically in Chinese. A pivotal element of this initiative is the adoption of ISO 10646, an international coding standard being developed under the aegis of the International Organisation for Standardisation (ISO) to embrace characters used in all major languages in the world.

The current version of ISO 10646 has defined 20 902 ideographic characters. Its next version

will cover more than 27 000 ideographic characters. All characters in the HKSCS which are not included in the existing version of ISO 10646 have already been submitted to the Ideographic Rapporteur Group (IRG), a working group under ISO, and will be considered for inclusion in future releases of ISO 10646.

Through the development of the HKSCS and participation in the development of ISO 10646, the HKSAR is well on its way to establishing a common Chinese language interface in the long term.

Acknowledgement

This specification was completed with invaluable assistance from CLIAC. We would like to thank the following committee members for their contribution: Mr. C. L. CHAN, Mr. Dominic CHENG, Mr. Raymond CHENG, Dr. K.H. CHEUNG, Dr. W.C. KEUNG, Mr. Francis LEE, Mr. Fan LOOK, Dr. Qin LU, Dr. K.K. LUKE, Mr. Lawrence MO, Mr. Arics POON, Mr. Tony TAI, Mr. H.T. TSANG, Prof. Benjamin TSOU and Mr. T.H. YAO. We would also like to thank the two working groups under CLIAC for their great effort : the Working Group on Characters for Chinese Computer Systems chaired by Dr. K.H. CHEUNG and the Working Group on Chinese Information Processing chaired by Dr. Qin LU.

Section 1 Overview

- 1.1 This document specifies the overall architecture and coding assignment of the Hong Kong Supplementary Character Set (HKSCS) in Big-5 and provides the mapping of the HKSCS to ISO 10646 v1.0 and the upcoming ISO 10646 v2.0. In Big-5, the HKSCS is defined in the User-Defined Areas and Vendor-Defined Areas and is fully compatible with the Government Common Character Set (GCCS). Characters in the HKSCS which are not defined in ISO 10646 v1.0 and ISO 10646 v2.0 are defined in the Private Use Area of ISO 10646.
- 1.2 The HKSCS is a coded character set. It is not meant to be a glyph standard. The glyphs used in this document are only representatives of the characters to be defined.
- 1.3 For the purpose of this document, the following definitions will apply:

Backward compatibility	A newer version of a standard/specification which still supports the code point assignment in older versions of the same standard/specification. Sometimes it also refers to a new standard supporting all the characters in the base standards from which the new standard is produced.
Block	A continuous collection of characters that share common characteristics.
Character	A member of a set of elements used for the organisation, control, or representation of data.
Character set	A defined set of characters.
Code point	An assigned binary code value to represent a character.
Coded character set	A set of unambiguous rules that establishes a character set and the relationship between the characters of the set and their coded representation.
Glyph	An abstractly identified graphic symbol independent of any actual image, thus an abstraction of the actual image.

Government Common Character Set (GCCS)	A coded character set developed by the Hong Kong Government in 1995 for Chinese character interchange and processing within the Government.
ISO 10646	An ISO standard on a coded character set. Its official name is “Information technology - Universal Multiple-Octet Coded Character Set (UCS)”. It aims at providing one single character set to encompass the characters of all major languages.
ISO 10646 v1.0	The first ISO 10646 standard published in 1993, which consists of 20 902 ideograph characters from China, Japan and Korea. The reference number is “ISO/IEC 10646-1:1993”.
ISO 10646 v2.0	The next release of ISO 10646 scheduled for publication in 2000. It is an extension to ISO 10646 v1.0 with 6 582 additional ideographic characters (defined in the Extension A), 214 Kang Xi radicals, and other symbols.
Octet	An ordered sequence of eight bits considered as a unit.
Private Use Area (PUA)	A block of code points in ISO 10646 reserved for users and vendors to give their own definitions. The ISO 10646 PUA, in principle, is intended for use by individuals or vendors privately and not for data interchange.
User-Defined Areas (UDAs)	Blocks of code points in Big-5 reserved for users to give their own definitions. The Big-5 UDAs, in principle, are intended for personal use and not for data interchange.
Unification	The process of assigning one code point to two or more graphic symbols which, though seemingly different, are actually variants representing the same element in data representation. Consequently, only one of the variants is selected as the representative.
Vendor-Defined Areas (VDAs)	Blocks of code points in Big-5 reserved for vendors to give their own definitions. Some systems, however, allow end-users to make use of these areas for their individual use.

Section 2 Code Allocation of the HKSCS in Big-5

2.1 Big-5 is a fixed 2-octet coding scheme which consists of 13 053 traditional Chinese characters. It is a *de facto* industrial standard commonly used in Taiwan and the HKSAR. The ranges of the octets are as follows:

First Octet : 0x81 - 0xFE

Second Octet: 0x40 - 0x7E, 0xA1 - 0xFE

The current coding assignment and architecture of Big-5 is shown as follows:

Range	Name of Block (Total code points)
8140 – 8DFE	User-Defined Area 3 (UDA3) (2 041 code points)
8E40 – A0FE	User-Defined Area 2 (UDA2) (2 983 code points)
A140 – A3FE	Big-5 Symbols and Control Codes (471 code points)
A440 – C67E	Big-5 Primary Character Set (5 401 code points)
C6A1 – C8FE	Vendor-Defined Area (VDA) (408 code points)
C940 – F9D5	Big-5 Secondary Character Set (7 652 code points)
F9D6 – F9FE	Vendor-Defined Area (VDA) (41 code points)
FA40 – FEFE	User-Defined Area 1 (UDA1) (785 code points)

2.2. The HKSCS is an updated version of the GCCS. It includes 4 702 characters of which 2 943 are already in the GCCS and 1 759 are newly added. Most of the characters in the HKSCS are defined in the User-Defined Areas and some of them are defined in the Vendor-Defined Areas. Below is a summary of the allocation of code ranges for the HKSCS in Big-5:

- User-Defined Area 1 (FA40 – FEFE) : 763 characters
- User-Defined Area 2 (8E40 – A0FE) : 2 898 characters
- User-Defined Area 3 (8140 – 8DFE) : 641 characters
- Vendor-Defined Area (C6A1 – C8FE) : 359 characters
- Vendor-Defined Area (F9D6 – F9FE) : 41 characters

2.3 UDA3 is partly occupied by the HKSCS. To facilitate the management of the UDA, UDA3 is further divided into two parts as indicated below. The first block in UDA3 is not occupied by the HKSCS and it will not be used by future extensions of the HKSCS. The unassigned code points in the second block of UDA 3 may be used by future extensions of the HKSCS.

Range (Total code points)	Sub-blocks (Total code points)	Purpose
User-Defined Area 3 (UDA3) 8140 – 8DFE (2 041 code points)	8140 – 84FE (628 code points)	Will not be used by the HKSCS nor for future extensions of the HKSCS.
	8540 – 8DFE (1 413 code points)	Reserved for the HKSCS. Currently, 641 characters are defined.

2.4 All the GCCS characters in the HKSCS are to retain their original code points. Characters found as variants of other characters in Big-5 are unified and thus not included in the HKSCS. Characters not verifiable in the GCCS are also excluded from the HKSCS. To maintain backward compatibility, the original code points occupied by these characters are still reserved in the HKSCS as compatibility points. The list of compatibility points and their corresponding characters in Big-5 is at Annex I.

2.5 Table 2.1 is the code table of the HKSCS in Big-5. Each cell in the table represents a single code point. The code point value of a cell is the column code concatenated with the row code. In each cell, the glyph representing the character is shown first, followed by its corresponding ISO 10646 v1.0 and ISO 10646 v2.0 codes. The ISO 10646 codes are included in the table to facilitate the migration from the Big-5 platform to ISO 10646-enabled platforms.

2.6 The following is an example of a typical cell in Table 2.1

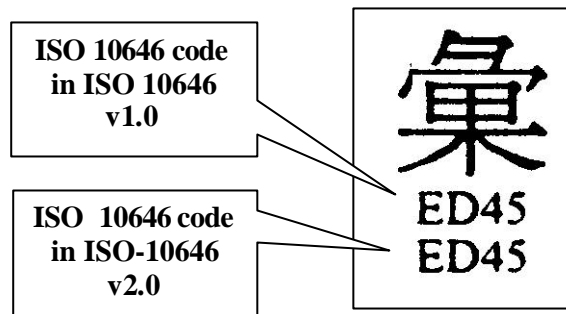

The following is an example of a cell representing a compatibility point in Table 2.1:

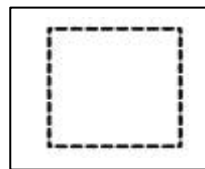

Table 2.1 – Code Table of the HKSCS in Big-5

FA40 – FEFE (UDA1)

	FA4	FA5	FA6	FA7	FAA	FAB	FAC	FAD	FAE	FAF
0	冇 E000 E000	杆 6744 6744	偃 E020 E020	丕 E030 E030		刊 520B 520B	滙 6ED9 6ED9	茆 E06E 44A2	眈 E07E 3F59	炆 7079 7079
1	鉷 92DB 92DB	拟 62DF 62DF	健 5FA4 5FA4	兪 516A 516A	鴿 9D34 9D34	刼 5226 5226	滙 E05F E05F	邛 536D 536D	玢 739C 739C	唸 552B 552B
2	逸 E002 E002	玳 E012 E012	傑 E022 E022	𠵼 E032 E032	涼 51C9 51C9	刼 523C 523C	匯 E060 E060	却 5374 5374	叁 53C1 53C1	哈 6657 6657
3	灌 E003 E003	鉦 E013 E013	傑 E023 E023	帽 E033 E033	減 51CF 51CF	券 52B5 52B5	滙 E061 E061	却 E071 E071	叅 53C5 53C5	洽 6D5B 6D5B
4	藟 854C 854C	儂 E014 E014	淫 6EDB 6EDB	偊 E034 E034	湊 51D1 51D1	剗 5257 5257	匱 5333 5333	鄂 537E 537E	汉 6C49 6C49	呖 546D 546D
5	紉 E005 42B5	茈 E015 E015	僚 E025 E025	徇 E035 E035	淋 E043 3CDC	劔 5294 5294	□	□	义 4E49 4E49	苳 E093 E093
6	瑛 73EF 73EF	堡 E016 E016	□	𠵼 E036 E036	凜 51D3 51D3	効 52B9 52B9	𠵼 E064 E064	卿 E074 E074	聖 57FE 57FE	唸 E094 E094
7	况 51B5 51B5	佞 4FAB 4FAB	僑 5101 5101	𠵼 E037 E037	凝 E045 E045	勅 52C5 52C5	泝 6CCB 6CCB	侯 E075 E075	叙 53D9 53D9	啱 555D 555D
8	𠵼 E008 3649	後 E018 E018	僑 E028 347A	孳 E038 E038	決 51B3 51B3	筋 7C15 7C15	妾 E066 E066	侯 77E6 77E6	𠵼 E086 3AAB	咏 548F 548F
9	跡 E009 E009	徠 5008 5008	𠵼 510E 510E	宄 5B82 5B82	凵 51E2 51E2	勝 8542 8542	協 681B 681B	厓 5393 5393	𠵼 E087 E087	咤 54A4 54A4
A	鋤 E00A E00A	蓆 E01A E01A	顛 986C 986C	蟠 877D 877D	凵 5342 5342	勑 52E0 52E0	琚 73D5 73D5	鏹 E078 E078	疊 53E0 53E0	趨 E098 47A6
B	鏹 9344 9344	諳 E01B E01B	𠵼 E02B 3743	𠵼 E03B E03B	凭 51ED 51ED	勳 860D 860D	協 604A 604A	厠 53A0 53A0	𠵼 E089 E089	姘 E099 E099
C	符 E00C E00C	樛 E01C E01C	莧 8416 8416	冰 E03C E03C	萘 83CD 83CD	茈 E05A E05A	𠵼 E06A 3EAA	𠵼 53AB 53AB	𠵼 E08A E08A	𠵼 E09A E09A
D	菡 82EE 82EE	璦 E01D E01D	琄 E02D E02D	冲 51B2 51B2	榭 693E 693E	□	𠵼 E06B 38CC	𠵼 53AE 53AE	叶 53F6 53F6	炆 E09B 3DB4
E	汕 E00E E00E	俸 E01E E01E	兒 E02E E02E	泮 51B8 51B8	櫛 E04C E04C	鋤 E05C E05C	姝 E06C E06C	玢 73A7 73A7	𠵼 E08C E08C	哲 E09C E09C
F	矜 783C 783C	□	𠵼 5160 5160		彻 5F7B 5F7B	唸 5549 5549	爆 71DD 71DD	𠵼 E07D E07D	吓 5413 5413	

	FB4	FB5	FB6	FB7	FBA	FBB	FBC	FBD	FBE	FBF
0	鎗 E09D E09D	皦 66CD 66CD	垠 5746 5746	叡 E0CD 3561		娣 E0EB E0EB	嫫 E0FB E0FB	寵 E10B E10B	嶋 5D8B 5D8B	櫛 E12B 3BC2
1	信 E09E E09E	皦 E0AE E0AE	灼 E0BE E0BE	壠 58E0 58E0	樊 E0DC E0DC	媢 E0EC E0EC	嫫 E0FC 3732	寶 5BF3 5BF3	寬 E11C E11C	幫 5E2E 5E2E
2	商 5547 5547	皦 66A4 66A4	洵 6C6E 6C6E	壘 58DC 58DC	婁 5A24 5A24	姹 59F9 59F9	妣 E0FD E0FD	宝 5B9D 5B9D	嶼 E11D E11D	櫛 6A8A 6A8A
3	鵬 E0A0 4CED	皦 66AD 66AD	炆 708B 708B	壬 E0D0 E0D0	啓 5553 5553	媣 E0EE E0EE	広 5E83 5E83	鸚 E10E 4D10	崑 5D10 5D10	□
4	启 542F 542F	噍 564D 564D	坂 5742 5742	堉 58FB 58FB	奮 E0DF E0DF	媣 5AAB 5AAB	勳 52D0 52D0	尅 5C05 5C05	崙 5D18 5D18	么 5E7A 5E7A
5	琫 7417 7417	喻 564F 564F	妊 E0C2 36B1	寿 5BFF 5BFF	蕙 8505 8505	媣 5A63 5A63	孳 5B76 5B76	尅 E110 E110	嵒 5D46 5D46	巖 E130 E130
6	喆 5586 5586	磬 78F1 78F1	苻 E0C3 E0C3	坑 5743 5743	姉 59C9 59C9	媣 E0F1 36E6	孳 6588 6588	尔 5C13 5C13	颯 E121 E121	岷 E131 E131
7	喻 55A9 55A9	囟 56F1 56F1	垠 57E6 57E6	鷓 E0D4 E0D4	咕 E0E2 E0E2	珥 E0F2 E0F2	孳 5B7C 5B7C	玆 73CE 73CE	岑 5CBA 5CBA	厦 53A6 53A6
8	□	鞞 9787 9787	堉 E0C5 E0C5	焜 E0D5 E0D5	媣 E0E3 E0E3	□	詭 E103 E103	尔 5C14 5C14	巖 5DD7 5DD7	廉 4EB7 4EB7
9	媣 E0A6 E0A6	𠂇 53FE 53FE	堉 5803 5803	鎡 93D3 93D3	蕙 E0E4 E0E4	媣 E0F4 3708	窳 E104 4004	甦 E114 E114	茈 82FC 82FC	□
A	熯 E0A7 E0A7	𠂇 5700 5700	𠂇 E0C7 E0C7	啜 E0D7 35A1	媣 E0E5 E0E5	媣 5A96 5A96	輓 E105 485D	茈 E115 E115	𠂇 E125 382D	厨 53A8 53A8
B	藟 E0A8 4552	𠂇 56EF 56EF	焜 E0C8 E0C8	够 591F 591F	姪 59D9 59D9	媣 7465 7465	佢 E106 E106	屮 5C49 5C49	坊 E126 E126	媣 E136 E136
C	熯 E0A9 E0A9	园 56ED 56ED	堉 5826 5826	梦 68A6 68A6	媣 E0E7 E0E7	媣 5AD3 5AD3	寧 5BD5 5BD5	郟 E117 48DD	巽 E127 E127	帟 5E09 5E09
D	曄 66B3 66B3	鎡 E0BA E0BA	瑩 E0CA E0CA	契 E0DA 36C3	媣 E0E8 E0E8	媣 E0F8 E0F8	傲 6160 6160	岷 5C85 5C85	幪 E128 E128	𠂇 5EF4 5EF4
E	噍 E0AB E0AB	圓 E0BB 3623	塚 585C 585C	湊 6E59 6E59	赫 E0E9 E0E9	律 E0F9 E0F9	寧 E109 E109	峩 5CE9 5CE9	芾 8287 8287	延 E139 E139
F	皦 5637 5637	圮 E0BC E0BC	整 58AA 58AA		派 6D71 6D71	濶 E0FA 3D85	寐 E10A E10A	峩 5CEF 5CEF	帆 E12A 3836	

	FC4	FC5	FC6	FC7	FCA	FCB	FCC	FCD	FCE	FCF
0	迫 5EF9 5EF9	彙 E14A E14A	鈇 E15A E15A	認 E16A E16A		拞 62D5 62D5	擘 64E5 64E5	旃 65D1 65D1	晰 E1B8 E1B8	欖 E1C8 E1C8
1	廻 5EFB 5EFB	彡 5F63 5F63	忽 6031 6031	璉 74A4 74A4	懋 E179 E179	擻 E189 E189	鑿 947B 947B	礮 E1A9 40D8	皙 6673 6673	□
2	廻 E13C 38A0	鞦 97BD 97BD	暄 6685 6685	德 50E1 50E1	憐 61D3 61D3	拊 636C 636C	攜 E19A 3A66	嫫 E1AA E1AA	□	杌 6767 6767
3	迺 5EFC 5EFC	彡 E14D E14D	媿 E15D E15D	媿 5AA0 5AA0	鑿 E17B E17B	瑄 E18B E18B	携 643A 643A	无 65E0 65E0	岿 E1BB E1BB	空 6762 6762
4	栾 683E 683E	鬲 5F72 5F72	恣 E15E 3963	慤 6164 6164	駮 E17C E17C	捷 E18C 3A17	携 E19C 3A57	旣 65E3 65E3	暢 E1BC E1BC	杰 E1CC E1CC
5	鐸 941B 941B	鐸 9340 9340	玦 E15F 3DC7	螢 8424 8424	懷 61D0 61D0	揅 6438 6438	敍 654D 654D	攸 5FDF 5FDF	暹 E1BD E1BD	霽 E1CD E1CD
6	式 5F0D 5F0D	卸 E150 E150	些 E160 3639	憑 6142 6142	恣 E17E 3932	揅 63F8 63F8	激 6F16 6F16	杖 E1AE E1AE	曉 E1BE E1BE	枯 67D7 67D7
7	伺 E141 E141	徧 5FA7 5FA7	空 5790 5790	慈 E171 E171	聰 E17F E17F	埠 E18F E18F	璫 E19F E19F	另 6618 6618	曙 E1BF E1BF	稜 E1CF 44E9
8	弢 E142 E142	薇 5DB6 5DB6	慇 E162 E162	墓 E172 E172	愼 E180 E180	嫁 E190 E190	整 E1A0 E1A0	昉 E1B0 E1B0	曜 77C5 77C5	栢 6822 6822
9	眈 E143 3ADE	澗 E153 3D5F	祝 7971 7971	慇 6181 6181	恣 6023 6023	□	斲 6585 6585	昏 E1B1 E1B1	懼 E1C1 E1C1	洧 6E50 6E50
A	逦 E144 48AE	暎 E154 E154	特 E164 3E40	憑 51F4 51F4	慇 615C 615C	溥 6F8A 6F8A	斲 656D 656D	暎 6644 6644	馥 99A4 99A4	鉞 923C 923C
B	埴 E145 E145	薇 E155 E155	悞 609E 609E	憑 E175 E175	攤 651E 651E	撮 E193 E193	斲 655F 655F	脊 E1B3 E1B3	勗 6702 6702	柳 6801 6801
C	强 5F3A 5F3A	薇 E156 E156	□	憇 6187 6187	抵 638B 638B	頓 9814 9814	斗 E1A4 E1A4	𤇗 E1B4 E1B4	燭 E1C4 E1C4	柴 E1D4 E1D4
D	彌 E147 E147	忉 E157 E157	憇 60B3 60B3	宪 5BAA 5BAA	承 E185 E185	瀕 E195 E195	斲 65B5 65B5	晋 664B 664B	瑚 E1C5 E1C5	稊 E1D5 E1D5
E	弘 E148 E148	鈞 91D6 91D6	璽 E168 E168	潘 E178 E178	担 62C5 62C5	榞 E196 E196	珍 E1A6 E1A6	嘜 E1B6 E1B6	瞽 E1C6 3B2B	桡 685D 685D
F	□	德 E159 E159	琤 E169 E169		姪 E187 E187	擡 64E1 64E1	飴 E1A7 4B37	皓 6667 6667	糠 69FA 69FA	

	FD4	FD5	FD6	FD7	FDA	FDB	FDC	FDD	FDE	FDF
0	𣎵 E1D7 E1D7	縊 E1E7 42FC	靈 E1F7 E1F7	漚 E207 E207		漚 6F04 6F04	湏 6E4F 6E4F	霽 E245 E245	灋 704B 704B	焯 714A 714A
1	櫟 69E1 69E1	櫟 6936 6936	龔 E1F8 3C0D	𣎵 6BDC 6BDC	𣎵 E216 E216	琿 E226 E226	媼 5A91 5A91	澍 E246 3D3B	灾 707E 707E	□
2	榑 6A0B 6A0B	渠 6998 6998	鬱 6B1D 6B1D	氷 6C37 6C37	媾 E217 3E5	澗 E227 E227	斂 E237 E237	凜 6F9F 6F9F	炆 70A7 70A7	岬 5C9C 5C9C
3	鏢 E1DA E1DA	渠 E1EA 3BA1	臯 E1FA E1FA	衫 E20A E20A	𣎵 E218 3CEB	漚 E228 E228	澹 6FF8 6FF8	灑 E248 E248	炆 7081 7081	煦 E268 E268
4	煤 6973 6973	榦 E1EB E1EB	愀 60DE 60DE	玳 E20B E20B	嗜 E219 E219	蒨 8533 8533	媼 E239 370D	灑 6FD3 6FD3	炆 70CC 70CC	焯 714F 714F
5	梨 68C3 68C3	榮 8363 8363	欸 6B35 6B35	苧 E20C E20C	𣎵 9B83 9B83	蒨 E22A E22A	滙 6F9D 6F9D	灑 E24A E24A	威 70D5 70D5	錕 9362 9362
6	榭 E1DD E1DD	倜 5090 5090	歷 6B74 6B74	汚 6C5A 6C5A	溘 E21B E21B	淞 51C7 51C7	滙 E23B E23B	灑 E24B E24B	栽 70D6 70D6	曷 E26B E26B
7	榭 6901 6901	榭 69F9 69F9	歷 E1FE E1FE	𣎵 8226 8226	𣎵 E21C E21C	□	滙 6EFA 6EFA	濬 E24C E24C	烟 70DF 70DF	煬 712C 712C
8	椀 6900 6900	檄 E1EF E1EF	澱 6EB5 6EB5	泓 6C79 6C79	𣎵 7F8F 7F8F	□	灑 E23D E23D	濬 E24D E24D	裊 E25D 4104	燈 E26D E26D
9	灑 E1E0 3D32	膠 E1F0 E1F0	穀 E200 E200	潑 E210 E210	样 6837 6837	箭 842E 842E	漪 E23E E23E	漢 E24E E24E	燂 E25E 3DE8	璵 E26E E26E
A	揅 E1E1 3A01	榭 6A45 6A45	倜 E201 E201	苧 E211 44C5	苧 E21F E21F	鏢 E22F E22F	灑 E23F 4555	灑 E24F E24F	焯 71B4 71B4	璞 E26F E26F
B	槩 E1E2 E1E2	檄 E1F2 E1F2	孳 E202 E202	灑 E212 E212	落 E220 E220	□	鏞 93F0 93F0	灑 51DF 51DF	焯 7196 7196	燂 71BA 71BA
C	榭 E1E3 3B80	檄 6A9D 6A9D	𣎵 E203 3740	焮 E213 E213	薄 E221 E221	游 E231 E231	灑 6F44 6F44	灑 E251 E251	燂 E261 E261	鑊 E271 E271
D	杓 67AC 67AC	檄 E1F4 3BF3	吡 5421 5421	玳 E214 E214	涖 6D96 6D96	琿 7453 7453	潜 6F5C 6F5C	瀛 E252 E252	焯 712B 712B	焯 70BD 70BD
E	榆 6961 6961	桤 67B1 67B1	𣎵 E205 E205	𣎵 E215 E215	浜 6D5C 6D5C	潛 E233 E233	潤 E243 3D4E	瀛 E253 E253	焯 7145 7145	燂 720E 720E
F	鎚 E1E6 E1E6	檄 6AC8 6AC8	毡 6BE1 6BE1		涖 6E7C 6E7C	焯 79CC 79CC	渚 6F74 6F74	縊 E254 E254	媼 5A88 5A88	

	FE4	FE5	FE6	FE7	FEA	FEB	FEC	FED	FEE	FEF
0	鑣 9442 9442	澤 6F3D 6F3D	灼 E294 E294	璵 E2A4 E2A4		鏢 9385 9385	癰 766F 766F	嶺 E2E2 E2E2	棊 68CA 68CA	裨 7986 7986
1	爨 7215 7215	犁 7282 7282	姦 E295 E295	璫 7460 7460	灑 E2B3 E2B3	畵 754D 754D	𠂇 7676 7676	眞 771E 771E	礪 78AF 78AF	祺 8900 8900
2	燮 5911 5911	□	璵 E296 E296	隅 E2A6 E2A6	壁 E2B4 E2B4	畵 754A 754A	玃 E2D4 E2D4	眦 7726 7726	礪 78C7 78C7	椽 6902 6902
3	鑠 9443 9443	猫 732B 732B	眇 6623 6623	璫 7447 7447	鏢 E2B5 E2B5	畧 7567 7567	臯 7690 7690	着 7740 7740	礎 78D3 78D3	稟 7980 7980
4	爛 7224 7224	猴 E288 E288	姍 E298 36C5	珣 73E4 73E4	櫻 5B46 5B46	晦 756E 756E	臯 81EF 81EF	搯 64AF 64AF	墜 96A5 96A5	穉 E306 E306
5	斂 9341 9341	猷 E289 E289	珩 E299 E299	瑤 7476 7476	鏢 E2B7 E2B7	碗 E2C7 E2C7	嶧 E2D7 37F8	睿 E2E7 E2E7	礪 792E 792E	襖 799D 799D
6	兀 E27A E27A	猷 E28A 48ED	珮 E29A E29A	瑩 83B9 83B9	嫫 E2B8 E2B8	璣 E2C8 3F04	臯 E2D8 E2D8	叢 7758 7758	礪 E2F8 E2F8	禮 E308 E308
7	炮 722E 722E	猷 E28B E28B	璇 E29B E29B	瑩 746C 746C	璣 74C8 74C8	疋 E2C9 E2C9	臯 E2D9 E2D9	瞬 E2E9 E2E9	磚 78D7 78D7	礼 793C 793C
8	牀 7240 7240	爰 7328 7328	珣 73F7 73F7	爍 E2AC 3730	彥 E2BA E2BA	疎 758E 758E	皦 76A1 76A1	矚 77AF 77AF	礪 7934 7934	襪 79A9 79A9
9	琿 E27D E27D	猷 732E 732E	琿 7415 7415	殼 7474 7474	甄 750E 750E	瑄 745D 745D	皦 76A5 76A5	舒 E2EB E2EB	碱 78B1 78B1	馮 6E2A 6E2A
A	栳 68BD 68BD	珏 73CF 73CF	桴 6903 6903	鐔 93F1 93F1	□	疔 759E 759E	鼓 76B7 76B7	鈺 E2EC E2EC	奶 E2FC E2FC	藪 E30C E30C
B	牕 7255 7255	玲 73AA 73AA	琦 E29F E29F	櫛 6A2C 6A2C	嘗 751E 751E	疔 75B4 75B4	盃 76CC 76CC	物 E2ED E2ED	奶 8FB8 8FB8	玠 E30D 3EA8
C	牖 7257 7257	咄 E290 E290	槩 7439 7439	璩 7482 7482	隄 E2BE E2BE	瘕 7602 7602	蓋 E2DE E2DE	疔 77F4 77F4	袄 8884 8884	秆 79C6 79C6
D	羣 E281 3E55	舩 E291 E291	涸 E2A1 E2A1	鏹 E2B1 4953	甯 E2BF E2BF	瘕 762C 762C	蓋 8462 8462	□	釧 E2FF E2FF	靛 E30F E30F
E	牽 E282 E282	珉 73C9 73C9	斐 E2A2 3ED7	璩 E2B2 E2B2	甯 5BD7 5BD7	瘕 7651 7651	盒 E2E0 E2E0	整 E2F0 E2F0	綉 E300 E300	杭 79D4 79D4
F	柱 680D 680D	璫 7449 7449	□		隄 E2C1 E2C1	瘕 764F 764F	會 E2E1 E2E1	璫 E2F1 E2F1	伺 E301 E301	

8E40 – A0FE (UDA2)

	8E4	8E5	8E6	8E7	8EA	8EB	8EC	8ED	8EE	8EF
0	滂 E311 E311	窰 7AB0 7AB0	筠 E331 E331	籊 7C35 7C35		縵 7DF5 7DF5	罈 E36F E36F	□	脚 811A 811A	艇 E39F E39F
1	埠 57BE 57BE	寮 7AC2 7AC2	筓 7BA2 7BA2	簾 E342 E342	縵 7E67 7E67	嫩 E360 E360	罵 99E1 99E1	穫 802F 802F	潭 58B0 58B0	涇 E3A0 E3A0
2	稯 E313 E313	竈 7AC3 7AC3	筓 7B6F 7B6F	簾 7C44 7C44	縵 E351 451D	縵 7DE5 7DE5	羗 7F97 7F97	鶻 E381 E381	𪗇 E391 E391	𪗈 4FF9 4FF9
3	炆 713E 713E	燿 71D1 71D1	莖 839C 839C	粃 7C83 7C83	莖 E352 E352	轉 E362 E362	羗 E372 E372	𪗈 E382 E382	汙 6C7F 6C7F	壥 E3A2 E3A2
4	稽 E315 E315	翻 E325 E325	筱 E335 E335	獠 E345 E345	縵 7D5D 7D5D	□	羗 7FA3 7FA3	耻 803B 803B	翻 E393 E393	𪗈 84E2 84E2
5	城 E316 364E	竝 E326 41CA	莖 E336 E336	莖 7CA6 7CA6	莖 E354 E354	縵 E364 E364	羗 E374 E374	𪗈 803C 803C	𪗈 E394 E394	芋 8362 8362
6	椽 69A2 69A2	𪗈 7ADA 7ADA	籊 7BD0 7BD0	𪗈 667D 667D	𪗈 748D 748D	縵 E365 E365	𪗈 E375 E375	𪗈 8061 8061	舉 64E7 64E7	𪗈 E3A5 E3A5
7	鑿 E318 E318	竝 7ADD 7ADD	莖 8421 8421	𪗈 E348 E348	縵 7D89 7D89	縵 7E6E 7E6E	羗 E376 455C	𪗈 E386 E386	舉 E396 E396	𪗈 E3A6 E3A6
8	香 5B74 5B74	豎 7AEA 7AEA	筓 7B92 7B92	粳 7CC9 7CC9	縵 7DAB 7DAB	縵 7E92 7E92	𪗈 E377 E377	𪗈 E387 4989	館 8218 8218	𪗈 E3A7 E3A7
9	穉 7A49 7A49	筓 E32A 41EF	□	猴 7CC7 7CC7	炯 7135 7135	纜 E368 432B	𪗈 E378 4503	肇 E388 E388	𪗈 E398 E398	𪗈 E3A8 E3A8
A	穉 E31B E31B	𪗈 54B2 54B2	纂 E33B E33B	糝 7CE6 7CE6	縵 7DB3 7DB3	纜 946C 946C	𪗈 E379 E379	𪗈 E389 E389	𪗈 6A53 6A53	𪗈 E3A9 E3A9
B	穎 E31C E31C	籊 E32C E32C	𪗈 E33C 3DAD	𪗈 7C74 7C74	□	縵 7E27 7E27	𪗈 7FFA 7FFA	𪗈 E38A E38A	𪗈 E39A E39A	𪗈 82AA 82AA
C	𪗈 7A65 7A65	筓 7B0B 7B0B	籊 E33D E33D	𪗈 7CF3 7CF3	𪗈 E35B E35B	𪗈 7F40 7F40	𪗈 E37B E37B	𪗈 6725 6725	𪗈 E39B E39B	𪗈 691B 691B
D	𪗈 7A7D 7A7D	符 7B55 7B55	𪗈 8492 8492	𪗈 7CF5 7CF5	縵 E35C E35C	𪗈 7F41 7F41	□	𪗈 80A7 80A7	𪗈 E39C 447A	𪗈 E3AC E3AC
E	𪗈 E31F E31F	符 7B29 7B29	籊 7BFA 7BFA	□	縵 7DE4 7DE4	𪗈 7F47 7F47	𪗈 8008 8008	𪗈 E38D E38D	𪗈 8229 8229	𪗈 E3AD 41DB
F	窻 7ABB 7ABB	𪗈 E330 E330	□		𪗈 E35E 3D13	𪗈 7936 7936	𪗈 801D 801D	𪗈 8107 8107	𪗈 E39E E39E	

	8F4	8F5	8F6	8F7	8FA	8FB	8FC	8FD	8FE	8FF
0	莖 854B 854B	焯 E3BE 3DBF	蓄 8458 8458	苜 E3DE 44A0		蟲 8771 8771	衛 885E 885E	鮮 89E7 89E7	砮 E42C E42C	贖 E43C E43C
1	莖 82D0 82D0	莖 831D 831D	箏 E3CF E3CF	莖 8493 8493	藎 E3ED E3ED	鸚 E3FD E3FD	袜 889C 889C	觥 E41D E41D	砮 E42D E42D	嬭 E43D 3725
2	莖 831A 831A	啣 55EC 55EC	葱 8471 8471	菱 84E4 84E4	藎 E3EE E3EE	蟾 87EE 87EE	襪 E40E 465B	譜 E41E E41E	嘲 8B3F 8B3F	昭 E43E E43E
3	唅 E3B1 E3B1	莅 8385 8385	葱 E3D1 3DD3	筭 E3E1 E3E1	藎 85C1 85C1	游 E3FF E3FF	袴 88B4 88B4	諛 8A9C 8A9C	譏 8B4C 8B4C	賒 8CD6 8CD6
4	嬖 E3B2 E3B2	紗 E3C2 450B	葱 E3D2 44E4	簾 E3E2 4240	藻 E3F0 E3F0	蟹 87B1 87B1	袵 88B5 88B5	瞞 7793 7793	膺 8B4D 8B4D	賚 E440 E440
5	嬖 E3B3 36C1	薺 E3C3 E3C3	櫛 6AA7 6AA7	箴 E3E3 E3E3	藥 8602 8602	螫 87DA 87DA	擯 63C1 63C1	鈎 91FE 91FE	詒 8AA9 8AA9	賜 E441 E441
6	崑 E3B4 E3B4	菟 83AC 83AC	葦 844A 844A	蔭 E3E4 4543	夔 E3F2 E3F2	蟻 880F 880F	裝 88C5 88C5	識 8A90 8A90	儀 E432 E432	贄 8D12 8D12
7	棧 E3B5 E3B5	□	沢 E3D5 E3D5	蔴 8534 8534	夔 E3F3 E3F3	瞻 5661 5661	睫 7777 7777	誕 E423 E423	聾 8B90 8B90	聰 8D03 8D03
8	芳 827B 827B	菓 83D3 83D3	祿 7958 7958	嫵 5AF2 5AF2	夔 E3F4 E3F4	虬 866C 866C	裘 E414 E414	誼 7AE9 7AE9	讒 8B9B 8B9B	嬖 E444 E444
9	苜 82E2 82E2	儻 E3C7 347E	□	犂 E3E7 E3E7	薄 E3F5 456A	榘 6856 6856	霸 8987 8987	諱 E425 E425	詔 8AAF 8AAF	贄 8CDB 8CDB
A	荔 8318 8318	夔 E3C8 E3C8	芡 E3D8 E3D8	藜 E3E8 4527	藜 8628 8628	郵 E406 460F	羈 898A 898A	漪 E426 E426	娥 E436 E436	瀛 705C 705C
B	滿 E3B9 E3B9	楠 6A57 6A57	培 E3D9 E3D9	簡 8573 8573	墟 E3F7 3648	畔 8845 8845	□	諫 E427 4713	衍 E437 4615	顛 8D11 8D11
C	蒺 E3BA E3BA	萼 855A 855A	落 E3DA E3DA	蔭 E3EA 4516	嬖 E3F8 E3F8	衆 8846 8846	□	譖 E428 E428	衍 884F 884F	嘆 E448 E448
D	苜 E3BB E3BB	儻 E3CB 3496	蓄 84DE 84DE	枿 67BF 67BF	号 53F7 53F7	衍 E409 E409	覽 89A7 89A7	燭 717C 717C	糴 8C9B 8C9B	琰 E449 3ED0
E	茵 E3BC E3BC	藜 E3CC E3CC	□	藜 8616 8616	蝦 E3FA E3FA	衍 E40A E40A	覲 89BC 89BC	訶 8B0C 8B0C	頁 E43A E43A	□
F	橙 E3BD E3BD	孛 E3CD E3CD	葦 8391 8391		虾 867E 867E	衍 E40B E40B	鏊 E41B E41B	諂 8B1F 8B1F	頁 E43B E43B	

	904	905	906	907	90A	90B	90C	90D	90E	90F
0	𪔐 8DA9 8DA9	𪔑 8FA5 8FA5	𪔒 E46B 3980	𪔓 91A9 91A9		𪔔 945B 945B	𪔕 E4A9 416C	𪔖 E4B9 E4B9	𪔗 E4C9 E4C9	𪔘 E4D9 E4D9
1	𪔙 E44C E44C	𪔚 9303 9303	𪔛 E46C E46C	𪔜 91C4 91C4	𪔝 E48A E48A	𪔞 8EBC 8EBC	𪔟 96A3 96A3	𪔠 E4BA E4BA	𪔡 975F 975F	□
2	𪔢 E44D E44D	𪔣 E45D E45D	𪔤 9037 9037	𪔥 7CAC 7CAC	𪔦 932C 932C	𪔧 9585 9585	𪔨 E4AB E4AB	𪔩 9731 9731	𪔪 9425 9425	𪔫 97F5 97F5
3	𪔬 E44E E44E	𪔭 E45E E45E	𪔮 E46E E46E	𪔯 E47E E47E	𪔰 936B 936B	𪔱 95A6 95A6	𪔲 61DA 61DA	𪔳 8642 8642	𪔴 50D0 50D0	𪔵 E4DC E4DC
4	𪔶 E44F 3B7C	𪔷 8FB3 8FB3	𪔸 E46F E46F	𪔹 E47F E47F	𪔺 E48D E48D	𪔻 9426 9426	𪔼 96B6 96B6	𪔽 9736 9736	𪔾 E4CD E4CD	𪔿 E4DD E4DD
5	𪔿 E450 E450	𪕀 E460 492A	𪕁 9061 9061	𪕂 920E 920E	𪕃 E48E E48E	𪕄 95A0 95A0	𪕅 78F5 78F5	𪕆 E4BE 4A0F	𪕇 E4CE E4CE	𪕈 E4DE 4AD1
6	𪕉 E451 E451	𪕊 E461 E461	𪕋 E471 E471	𪕌 6C9F 6C9F	𪕍 708F 708F	𪕎 6FF6 6FF6	𪕏 E4AF E4AF	𪕐 E4BF 453D	𪕑 9789 9789	𪕒 9834 9834
7	𪕓 7AE7 7AE7	𪕔 E462 E462	𪕕 E472 E472	𪕖 9241 9241	𪕗 5AC3 5AC3	𪕘 E4A0 42B9	𪕙 96BD 96BD	𪕚 E4C0 4585	𪕛 979F 979F	𪕜 9833 9833
8	𪕝 8EAD 8EAD	𪕞 E463 E463	𪕟 90A8 90A8	𪕠 9262 9262	𪕡 E491 E491	𪕢 E4A1 E4A1	𪕣 53CC 53CC	𪕤 E4C1 E4C1	𪕥 97B1 97B1	𪕦 984B 984B
9	𪕧 8EB6 8EB6	𪕨 5EF8 5EF8	𪕩 E474 E474	𪕪 E484 E484	𪕫 E492 E492	𪕬 E4A2 E4A2	𪕭 E4B2 49A1	𪕮 7075 7075	𪕯 97BE 97BE	𪕰 9866 9866
A	𪕱 8EC3 8EC3	𪕲 E465 E465	𪕳 90C4 90C4	□	𪕵 E493 4965	𪕶 E4A3 E4A3	𪕷 E4B3 E4B3	𪕸 5B41 5B41	𪕹 97C0 97C0	𪕺 E4E3 3B0E
B	𪕻 92D4 92D4	𪕼 8FF9 8FF9	𪕽 E476 E476	𪕾 E486 E486	𪕿 9244 9244	𪖀 E4A4 E4A4	𪖁 E4B4 E4B4	𪖂 971B 971B	𪖃 97D2 97D2	𪖄 E4E4 E4E4
C	𪖅 8F19 8F19	𪖆 E467 E467	𪖇 90AE 90AE	𪖈 E487 E487	𪖉 E495 E495	𪖊 E4A5 49DF	𪖋 E4B5 E4B5	□	𪖍 97E0 97E0	𪖎 E4E5 3D51
D	𪖏 8F2D 8F2D	𪖐 E468 E468	□	𪖒 E488 E488	𪖓 E496 E496	𪖔 6C1C 6C1C	𪖕 E4B6 E4B6	𪖖 E4C6 E4C6	𪖗 E4D6 E4D6	𪖘 E4E6 E4E6
E	𪖙 E459 E459	𪖚 E469 E469	𪖛 9167 9167	𪖜 E489 E489	𪖝 E497 E497	𪖞 967B 967B	𪖟 E4B7 E4B7	𪖠 9757 9757	𪖡 97EE 97EE	𪖢 E4E7 E4E7
F	𪖣 E45A E45A	𪖤 E46A E46A	𪖥 E47A 3AF0		𪖧 9373 9373	𪖨 9696 9696	𪖩 E4B8 E4B8	𪖪 5B4A 5B4A	𪖫 741C 741C	

	914	915	916	917	91A	91B	91C	91D	91E	91F
0	𩶛 E4E8 E4E8	𩶛 E4F8 E4F8	𩶛 9B14 9B14	𩶛 9BFF 9BFF		𩶛 9EAF 9EAF	𩶛 9F39 9F39	𩶛 7177 7177	𩶛 E566 E566	𩶛 E576 E576
1	𩶛 98CA 98CA	𩶛 E4F9 E4F9	𩶛 9B2D 9B2D	𩶛 9C0C 9C0C	𩶛 9DC4 9DC4	𩶛 E537 E537	𩶛 569F 569F	𩶛 E557 E557	𩶛 E567 E567	𩶛 E577 E577
2	𩶛 98B7 98B7	𩶛 99F5 99F5	𩶛 E50A E50A	𩶛 E51A E51A	𩶛 E528 E528	𩶛 9EC1 9EC1	𩶛 568A 568A	𩶛 E558 E558	𩶛 7217 7217	𩶛 E578 3722
3	𩶛 98C8 98C8	𩶛 9A0C 9A0C	𩶛 5034 5034	𩶛 9DD4 9DD4	𩶛 E529 E529	𩶛 E539 3B60	𩶛 9F45 9F45	𩶛 E559 E559	𩶛 E569 3EBB	𩶛 E579 E579
4	𩶛 98C7 98C7	𩶛 9A3B 9A3B	𩶛 9B34 9B34	𩶛 E51C E51C	𩶛 E52A E52A	𩶛 E53A 39E5	𩶛 99B8 99B8	𩶛 739E 739E	𩶛 7772 7772	𩶛 E57A E57A
5	𩶛 E4ED 4AFF	𩶛 9A10 9A10	𩶛 E50D E50D	𩶛 E51D E51D	𩶛 E52B E52B	𩶛 E53B 3D1D	𩶛 E54B E54B	𩶛 E55B E55B	𩶛 7A43 7A43	𩶛 E57B 36E1
6	𩶛 E4EE E4EE	𩶛 9A58 9A58	𩶛 E50E 38C3	𩶛 E51E E51E	𩶛 E52C E52C	𩶛 4F32 4F32	𩶛 97F2 97F2	𩶛 E55C E55C	𩶛 70D0 70D0	𩶛 E57C E57C
7	𩶛 E4EF E4EF	𩶛 E4FF E4FF	𩶛 E50F E50F	𩶛 E51F E51F	𩶛 9D39 9D39	𩶛 E53D 37BE	𩶛 847F 847F	𩶛 799F 799F	𩶛 E56D E56D	𩶛 E57D E57D
8	𩶛 55B0 55B0	𩶛 E500 36C4	𩶛 9B50 9B50	𩶛 E520 E520	𩶛 E52E E52E	𩶛 E53E E53E	𩶛 9F62 9F62	𩶛 E55E E55E	𩶛 E56E E56E	𩶛 E57E E57E
9	𩶛 98E1 98E1	𩶛 E501 E501	𩶛 9B40 9B40	𩶛 E521 E521	𩶛 E52F E52F	𩶛 9F02 9F02	𩶛 9F69 9F69	𩶛 E55F E55F	𩶛 717E 717E	𩶛 E57F 3723
A	𩶛 98E6 98E6	𩶛 E502 E502	𩶛 E512 E512	𩶛 9D7E 9D7E	𩶛 9E90 9E90	𩶛 9F08 9F08	𩶛 7ADC 7ADC	𩶛 9369 9369	𩶛 E570 E570	𩶛 E580 E580
B	𩶛 98EC 98EC	𩶛 9AE0 9AE0	𩶛 5A45 5A45	𩶛 9D83 9D83	𩶛 9E95 9E95	𩶛 E541 4B96	𩶛 9F8E 9F8E	𩶛 93F3 93F3	𩶛 70A3 70A3	𩶛 575B 575B
C	𩶛 9378 9378	𩶛 9AE2 9AE2	𩶛 E514 E514	𩶛 E524 E524	𩶛 9E9E 9E9E	𩶛 9424 9424	𩶛 7216 7216	𩶛 E562 E562	𩶛 E572 E572	𩶛 E582 E582
D	𩶛 9939 9939	𩶛 E505 E505	𩶛 9B8E 9B8E	𩶛 9E0E 9E0E	𩶛 9EA2 9EA2	𩶛 E543 E543	𩶛 E553 4BBE	𩶛 92EC 92EC	𩶛 E573 E573	𩶛 E583 E583
E	𩶛 E4F6 E4F6	𩶛 9AF4 9AF4	𩶛 E516 E516	𩶛 6888 6888	𩶛 E534 4D34	𩶛 9F17 9F17	𩶛 E554 E554	𩶛 9381 9381	𩶛 E574 3EC7	𩶛 E584 E584
F	𩶛 E4F7 4B72	𩶛 E507 4C0E	𩶛 9C02 9C02		𩶛 9EAA 9EAA	□	𩶛 E555 E555	𩶛 93CB 93CB	𩶛 E575 E575	

	924	925	926	927	92A	92B	92C	92D	92E	92F
0	𡗗 E585 E585	𡗘 67F9 67F9	𡗙 5692 5692	𡗚 E5B5 E5B5		□	𡗛 E5E3 E5E3	𡗜 E5F3 E5F3	𡗝 54CD 54CD	𡗞 5A2C 5A2C
1	𡗟 E586 E586	𡗠 E596 3733	𡗡 E5A6 E5A6	𡗢 5A68 5A68	𡗣 50CD 50CD	□	𡗤 8D7A 8D7A	□	𡗥 E604 E604	𡗦 59B8 59B8
2	𡗧 8503 8503	𡗨 E597 3C15	𡗩 E5A7 E5A7	𡗪 E5B7 E5B7	𡗫 510D 510D	□	𡗬 E5E5 E5E5	𡗭 E5F5 3EDE	𡗮 571D 571D	𡗯 928F 928F
3	𡗰 E588 E588	𡗱 E598 3DE7	𡗲 E5A8 E5A8	𡗳 E5B8 E5B8	𡗴 4FA2 4FA2	𡗵 6E76 6E76	𡗶 E5E6 E5E6	𡗷 7499 7499	𡗸 925D 925D	𡗹 5A7E 5A7E
4	□	𡗻 586C 586C	𡗼 93C6 93C6	𡗽 E5B9 3999	𡗾 4F03 4F03	𡗿 E5D7 E5D7	𡘀 5259 5259	𡘁 7414 7414	𡘂 96F4 96F4	𡘃 5ACF 5ACF
5	𡘄 8455 8455	𡘅 E59A E59A	𡘆 E5AA E5AA	𡘇 E5BA E5BA	𡘈 E5C8 E5C8	𡘉 E5D8 E5D8	𡘊 52A4 52A4	𡘋 7456 7456	𡘌 9366 9366	𡘍 5A12 5A12
6	𡘎 E58B E58B	𡘏 6810 6810	𡘐 939C 939C	𡘑 E5BB E5BB	𡘒 E5C9 E5C9	𡘓 E5D9 E5D9	𡘔 E5E9 E5E9	𡘕 7398 7398	𡘖 57DD 57DD	𡘗 E619 E619
7	𡘘 E58C E58C	𡘙 E59C 4057	𡘚 4EF8 4EF8	𡘛 E5BC 3435	𡘜 4F42 4F42	𡘝 6D72 6D72	𡘞 52E1 52E1	𡘟 E5FA 4B8E	𡘠 578D 578D	𡘡 E61A E61A
8	𡘢 E58D E58D	𡘣 E59D E59D	𡘤 512B 512B	𡘥 4F29 4F29	𡘦 502E 502E	𡘧 E5DB E5DB	□	𡘨 E5FB E5FB	𡘩 577F 577F	𡘪 E61B E61B
9	𡘫 E58E E58E	𡘬 E59E E59E	𡘭 E5AE 3819	𡘮 E5BE E5BE	𡘯 506C 506C	𡘰 E5DC E5DC	𡘱 E5EC 467A	𡘲 E5FC E5FC	𡘳 E60C 363E	𡘴 E61C E61C
A	𡘵 E58F E58F	𡘶 E59F E59F	𡘷 E5AF E5AF	𡘸 E5BF E5BF	𡘹 5081 5081	𡘺 51A8 51A8	𡘻 718C 718C	𡘼 53D0 53D0	𡘽 58CB 58CB	𡘾 E61D 36F5
B	𡘿 E590 E590	𡙀 E5A0 E5A0	𡙁 4EBC 4EBC	𡙂 E5C0 E5C0	𡙃 4FCC 4FCC	𡙄 51C3 51C3	𡙅 E5EE E5EE	𡙆 E5FE 3584	𡙇 5A99 5A99	𡙈 6D05 6D05
C	𡙉 E591 44F4	𡙊 E5A1 E5A1	𡙋 E5B1 E5B1	𡙌 8ADA 8ADA	𡙍 4FE5 4FE5	𡙎 E5DF E5DF	𡙏 E5EF E5EF	𡙐 720F 720F	𡙑 E60F E60F	𡙒 7443 7443
D	𡙓 E592 E592	𡙔 54CB 54CB	𡙕 E5B2 E5B2	𡙖 E5C2 E5C2	𡙗 5058 5058	𡙘 E5E0 44DD	𡙙 E5F0 E5F0	𡙚 E600 E600	𡙛 E610 E610	𡙜 5A21 5A21
E	𡙝 E593 E593	𡙞 569E 569E	𡙟 4F4B 4F4B	𡙠 4E98 4E98	𡙡 50FC 50FC	𡙢 E5E1 E5E1	𡙣 E5F1 E5F1	𡙤 55B4 55B4	𡙥 E611 E611	𡙦 E621 E621
F	𡙧 E594 E594	𡙨 E5A4 E5A4	𡙩 4F8A 4F8A		□	𡙪 E5E2 E5E2	𡙫 69D1 69D1	𡙬 E602 E602	𡙭 E612 E612	

	934	935	936	937	93A	93B	93C	93D	93E	93F
0	煒 5A81 5A81	獮 E632 E632	銅 E642 E642	仇 E652 E652		护 62A4 62A4	暖 E680 E680	煜 E690 E690	櫻 E6A0 3B99	櫛 6AC9 6AC9
1	鏗 E623 E623	預 E633 E633	弑 5F0C 5F0C	仇 E653 E653	搜 6471 6471	揎 E671 E671	畔 E681 3AE0	暎 668E 668E	樵 E6A1 E6A1	櫛 6B05 6B05
2	愷 E624 E624	尋 E634 E634	弑 5F0E 5F0E	惑 E654 E654	犛 E662 E662	犛 643B 643B	秦秦 E682 4190	莢 E692 E692	棧 E6A2 E6A2	嬖 E6B2 E6B2
3	鏗 93E0 93E0	廊 5ECD 5ECD	嬪 E645 E645	蕙 E655 E655	抗 E663 E663	敷 656B 656B	礮 E683 E683	晫 666B 666B	璫 74D0 74D0	擲 6511 6511
4	瑱 748C 748C	嬖 5B4F 5B4F	嫫 E646 E646	愠 61C0 61C0	揆 E664 3A29	械 6972 6972	鏊 E684 E684	駢 E694 4B93	樺 E6A4 3B96	梲 6898 6898
5	垵 E627 E627	嬖 E637 E637	媼 5A6B 5A6B	歪 E657 E657	吊 E665 E665	榕 E675 3BF4	磧 E685 E685	昱 6630 6630	枊 678F 678F	欄 6A4C 6A4C
6	焯 7105 7105	嬖 E638 E638	妹 E648 E648	歪 E658 E658	吊 E666 E666	漣 E676 E676	妊 E686 E686	覲 E696 E696	枊 E6A6 E6A6	欄 E6B6 3BD7
7	鏹 E629 4972	媼 E639 3701	嬖 5B44 5B44	忤 E659 E659	駮 E667 E667	𠄎 E677 E677	礮 E687 E687	崱 E697 E697	梲 68B6 68B6	欄 6A7A 6A7A
8	鐫 9408 9408	媼 E63A E63A	穎 8614 8614	熹 6199 6199	攢 E668 E668	聖 E678 E678	礮 E688 E688	晰 6663 6663	栳 681E 681E	獻 6B57 6B57
9	鋹 E62B E62B	媼 E63B 36DD	衡 E64B E64B	愷 6198 6198	擲 6337 6337	𠄎 E679 E679	礮 78EE 78EE	暎 E699 E699	釐 E6A9 3BC4	灑 E6B9 E6B9
A	鐫 93BD 93BD	媼 E63C E63C	衡 8860 8860	惠 6075 6075	斂 E66A E66A	皖 550D 550D	旗 E68A E68A	矇 E69A E69A	綦 6ABE 6ABE	汇 E6BA E6BA
B	屨 E62D 37A0	媼 E63D 36D3	忙 607E 607E	揆 E65D E65D	揆 64B6 64B6	濟 E67B E67B	媼 E68B E68B	晒 661E 661E	龍 E6AB 3863	鋹 93A0 93A0
C	奈 5C1E 5C1E	晞 812A 812A	懺 E64E E64E	揆 E65E E65E	抄 6331 6331	濟 E67C E67C	瞄 E68C E68C	穉 E69C E69C	櫟 E6AC E6AC	鋹 92F2 92F2
D	咋 5C9E 5C9E	鋪 E63F E63F	恣 E64F E64F	慢 E65F E65F	揆 63D1 63D1	韻 E67D E67D	備 E68D 3464	彪 E69D 38D1	燦 E6AD E6AD	鋹 E6BD E6BD
E	幪 5E5E 5E5E	颯 E640 E640	帆 5FDB 5FDB	靄 E660 E660	璉 E66E E66E	暎 66CE 66CE	暗 E68E E68E	櫟 E69E E69E	櫟 6A33 6A33	鎮 E6BE E6BE
F	幪 5E48 5E48	楓 E641 E641	壘 E651 3EB8		揆 E66F E66F	璉 E67F E67F	昱 E68F E68F	櫟 E69F E69F	櫟 6A52 6A52	

	944	945	946	947	94A	94B	94C	94D	94E	94F
0	肆 9289 9289	硃 7842 7842	璫 E6DF E6DF	菱 E6EF 4551		眈 770E 770E	礪 E71D E71D	稔 79F4 79F4	咄 E73D E73D	筮 E74D E74D
1	肆 E6C0 E6C0	焜 713B 713B	玨 E6E0 E6E0	瞳 7583 7583	燭 E6FE 3DCD	映 770F 770F	硃 781E 781E	穉 E72E 416E	咄 7AE2 7AE2	糲 E74E E74E
2	邛 E6C1 E6C1	焜 E6D1 E6D1	玨 E6E1 E6E1	曠 E6F1 3F63	璫 E6FF E6FF	暄 777B 777B	礪 788D 788D	炳 E72F E72F	嬋 5A59 5A59	粘 E74F E74F
3	鏡 9467 9467	焜 E6D2 E6D2	璫 E6E2 3F06	曠 E6F2 3E62	璫 E700 3E6F	暄 E710 E710	礪 7888 7888	柄 E730 4132	惺 E740 E740	糲 7CCD 7CCD
4	淳 6DA5 6DA5	焜 70F1 70F1	望 E6E3 3EB1	曠 E6F3 E6F3	璫 E701 E701	櫟 E711 E711	碩 78D2 78D2	鈞 9235 9235	嬋 E741 E741	滋 E751 E751
5	滢 6F0B 6F0B	插 7250 7250	瓏 E6E4 E6E4	吭 E6F4 3F58	玨 E702 E702	揆 E712 3A5E	珙 73D0 73D0	桐 79F1 79F1	婷 E742 E742	滋 E752 E752
6	璽 E6C5 E6C5	犇 7287 7287	鑿 E6E5 E6E5	畀 7555 7555	釵 91FA 91FA	玨 E713 E713	袂 7959 7959	喧 E733 E733	斌 5A0D 5A0D	粢 7C8E 7C8E
7	□	犇 7294 7294	漑 E6E6 E6E6	癩 7673 7673	玨 5732 5732	琯 7438 7438	禱 E724 E724	瑄 E734 E734	斌 E744 E744	粢 7C7C 7C7C
8	滢 E6C7 E6C7	狃 E6D7 E6D7	恹 60A7 60A7	齊 E6F7 E6F7	銓 9342 9342	璫 749B 749B	帶 E725 E725	值 E735 E735	礪 78F0 78F0	糧 7CAE 7CAE
9	滢 E6C8 3D8F	犇 E6D8 E6D8	玨 E6E8 3EF3	曠 E6F8 3B19	璫 E706 E706	玨 E716 3EBF	袴 E726 410E	涓 E736 E736	媯 5A2A 5A2A	糲 6AB2 6AB2
A	排 6E04 6E04	茲 5179 5179	瓏 74CC 74CC	璫 7468 7468	璫 E707 E707	璫 E717 E717	□	媯 E737 E737	綵 E747 E747	緜 7DDC 7DDC
B	滢 E6CA E6CA	璫 E6DA E6DA	瓏 743C 743C	鐳 E6FA E6FA	璫 50DF 50DF	璫 E718 E718	蕘 8496 8496	哿 E738 3597	筮 7AFE 7AFE	緜 7E07 7E07
C	婁 5A3D 5A3D	渙 E6DB E6DB	鐳 9387 9387	璫 E6FB E6FB	瞭 E709 E709	礪 E719 40C8	襪 79A5 79A5	嗜 556B 556B	箬 E749 41F9	緜 7DD3 7DD3
D	淵 6E0A 6E0A	璫 747A 747A	璫 7437 7437	璫 E6FC E6FC	瞭 E70A E70A	璫 E71A E71A	榭 6A2D 6A2D	吒 E73A 3570	籟 7C5D 7C5D	緜 7F4E 7F4E
E	瑄 5847 5847	滢 E6DD E6DD	苻 E6ED 449F	瞭 E6FD 3AFB	睞 7778 7778	繳 E71B E71B	溱 E72B E72B	媯 E73B 36AA	籟 7C6D 7C6D	緜 E75B E75B
F	淦 6D24 6D24	捰 E6DE E6DE	菱 E6EE E6EE		睞 E70C E70C	鎔 9307 9307	稗 7A3A 7A3A	佻 E73C E73C	篙 E74C 4211	

	954	955	956	957	95A	95B	95C	95D	95E	95F
0	寧 E75C E75C	劓 E76C E76C	藎 E77C E77C	諷 8610 8610		玕 E7AA 3EAD	負 8C9F 8C9F	廻 E7CA E7CA	鍬 E7DA E7DA	璩 E7EA 3EE7
1	譚 E75D E75D	笱 E76D E76D	莧 E77D E77D	齏 E78D E78D	袞 886E 886E	蓀 84A3 84A3	賒 8CE9 8CE9	迴 E7CB 489B	鐳 9427 9427	喻 E7EB E7EB
2	網 7D97 7D97	簞 E76E E76E	莧 E77E 44EA	嬖 5A86 5A86	侏 4F45 4F45	諷 E7AC 46F5	賒 E7BC E7BC	淋 6F79 6F79	鐳 E7DC E7DC	隨 968F 968F
3	糲 E75F E75F	芽 7B0C 7B0C	脰 8137 8137	稈 E78F 417F	柎 8887 8887	詭 E7AD 46CF	姪 599A 599A	湓 6E8B 6E8B	鏽 E7DD E7DD	陷 E7ED E7ED
4	甯 E760 426A	簞 E770 E770	腺 E780 4402	媼 E790 E790	袿 88BF 88BF	嶮 E7AE 37F2	瞞 77C3 77C3	媼 E7CE E7CE	莖 84E5 84E5	隄 E7EE E7EE
5	莘 E761 E761	鴛 99E6 99E6	胆 80C6 80C6	嫫 5B2B 5B2B	袞 88E6 88E6	詢 8A3D 8A3D	姁 59F0 59F0	鯨 9BE9 9BE9	訖 8A2B 8A2B	隄 E7EF E7EF
6	聿 E762 E762	騰 8645 8645	脉 8109 8109	嫫 E792 E792	襖 8965 8965	訖 8A1C 8A1C	挑 E7C0 436E	終 E7D0 36B5	鬧 9599 9599	琮 E7F0 3ECC
7	招 67D6 67D6	驕 9A63 9A63	裸 8142 8142	媼 5AE4 5AE4	襖 894D 894D	曠 E7B1 E7B1	蜂 E7C1 36D4	球 E7D1 E7D1	閔 95A7 95A7	琮 E7F1 E7F1
8	隼 E764 E764	樨 6A1C 6A1C	臄 E784 E784	媼 E794 E794	裡 E7A2 E7A2	曠 5F4D 5F4D	踪 8E2A 8E2A	邻 90BB 90BB	閔 9597 9597	璞 E7F2 E7F2
9	樨 E765 E765	柰 E775 E775	颯 98C3 98C3	蚕 86A0 86A0	襖 8954 8954	釵 922B 922B	躡 8EA7 8EA7	□	閑 9596 9596	漢 E7F3 E7F3
A	烽 57C4 57C4	拮 E776 39E2	旋 E786 E786	螻 E796 E796	襖 E7A4 E7A4	焜 E7B4 E7B4	甬 E7C4 E7C4	啮 5571 5571	閔 E7E4 E7E4	瑋 7412 7412
B	羿 E767 E767	琿 E777 E777	艦 8262 8262	漣 E797 E797	襖 E7A5 E7A5	旆 65D4 65D4	暢 8F30 8F30	醜 E7D5 4906	堤 7445 7445	瑁 746B 746B
C	抛 E768 E768	諭 E778 E778	艦 8265 8265	蠶 882D 882D	鍤 E7A6 E7A6	焜 7129 7129	轄 8F4A 8F4A	醜 91BB 91BB	珽 E7E6 3EC2	瑁 E7F6 3EFC
D	皓 E769 E769	諭 9A1F 9A1F	棘 E789 E789	螻 E799 E799	鍤 E7A7 E7A7	焜 70C4 70C4	綵 E7C7 42F4	鑽 9404 9404	珽 E7E7 E7E7	雷 9741 9741
E	翹 7FDD 7FDD	睽 E77A E77A	莖 8453 8453	烘 5A02 5A02	鑿 E7A8 E7A8	鳩 E7B8 E7B8	汗 6C58 6C58	鍔 E7D8 E7D8	璒 E7E8 E7E8	雷 E7F8 E7F8
F	筭 7B27 7B27	莖 8480 8480	莖 E78B E78B		翎 E7A9 E7A9	鷓 9D6D 9D6D	滋 6FBB 6FBB	睽 E7D9 4062	燐 E7E9 E7E9	

	964	965	966	967	96A	96B	96C	96D	96E	96F
0	架 6847 6847	鞞 979B 979B	翻 98DC 98DC	櫟 6A8F 6A8F		鰲 9C35 9C35	鶯 E857 E857	綈 E867 E867	馮 9064 9064	炆 E887 E887
1	霄 E7FA 4A1D	鞞 9771 9771	銛 E81A E81A	駮 9A21 9A21	堊 E838 E838	鰲 9C10 9C10	鶯 E858 E858	稔 79E2 79E2	礪 E878 E878	埧 57BB 57BB
2	零 E7FB E7FB	餽 9938 9938	璉 E81B 3F00	嬋 5AFE 5AFE	砒 7844 7844	鯨 9B7F 9B7F	鶻 9DA5 9DA5	椹 E869 E869	礪 783D 783D	壳 58F3 58F3
3	豨 E7FC E7FC	嚙 E80C E80C	鉅 922A 922A	騁 9A2F 9A2F	惘 E83A E83A	劓 9BCF 9BCF	蔥 84BD 84BD	榘 E86A E86A	砢 7854 7854	垠 578A 578A
4	□	嶠 5DC1 5DC1	銳 E81D 4925	駮 E82D E82D	溱 E83B E83B	鯨 E84B E84B	蔞 E85B E85B	銻 E86B 492D	礪 78B6 78B6	鷗 9D16 9D16
5	鏗 9368 9368	鑊 E80E E80E	菝 8414 8414	駟 E82E 4B90	榑 68C5 68C5	鮫 9B9F 9B9F	蔞 E85C E85C	璞 E86C E86C	砢 784B 784B	埧 57D7 57D7
6	鍊 E7FF E7FF	礪 E80F E80F	饒 993B 993B	馱 E82F E82F	澀 E83D 3D7D	鷗 E84D E84D	苜 E85D E85D	潘 E86D 3D62	媯 E87D E87D	焮 7134 7134
7	鑽 E800 E800	頡 981F 981F	饒 994D 994D	馱 99BC 99BC	鋤 9458 9458	鵠 E84E E84E	蕙 85FC 85FC	錦 93DB 93DB	晷 E87E E87E	燁 E88E 34AF
8	鐸 E801 E801	頡 E811 E811	譚 E821 E821	驪 E831 4BBD	怗 E83F 3927	鳴 9D21 9D21	蒸 E85F 4533	錄 92BE 92BE	珞 E87F E87F	焮 E88F E88F
9	擗 E802 E802	銃 92F6 92F6	燔 E822 3DFD	駢 E832 4B97	憇 6150 6150	鴉 E850 4CAE	蔭 E860 E860	鎡 9348 9348	吝 E880 369A	爍 71EB 71EB
A	莖 92BA 92BA	颶 E813 E813	馘 999B 999B	鎬 937D 937D	颯 E841 E841	鴻 E851 E851	薈 E861 E861	倅 E871 E871	倅 4F72 4F72	菁 E891 E891
B	嫫 5B11 5B11	鈔 91E5 91E5	舛 E824 4B6F	塲 5872 5872	慇 E842 E842	鸛 9E18 9E18	蔞 E862 E862	瑄 78B9 78B9	滌 6FDA 6FDA	煌 E892 E892
C	諤 8B69 8B69	菩 E815 44C0	馘 99AA 99AA	塗 E835 E835	悵 6107 6107	鴉 E853 4CB0	萌 8420 8420	鉞 9277 9277	澆 6FD9 6FD9	□
D	錄 E806 493C	鐔 E816 E816	驥 9A5C 9A5C	塲 5822 5822	鰾 9C4F 9C4F	鴉 9D0C 9D0C	蔞 85EE 85EE	嬰 944D 944D	□	煥 E894 E894
E	城 73F9 73F9	瑣 E817 E817	鏢 E827 E827	琫 E837 E837	鰾 9C53 9C53	鷄 E855 E855	蔞 E865 E865	倅 4FE4 4FE4	澆 701E 701E	鎬 E895 E895
F	炆 E808 E808	鑊 E818 E818	櫟 E828 E828		鰲 9C7B 9C7B	鵠 E856 E856	蔞 E866 E866	倅 E876 3440	吡 5414 5414	

	974	975	976	977	97A	97B	97C	97D	97E	97F
0	煥 610C 610C	擘 E8A6 E8A6	熨 E8B6 E8B6	焮 70A5 70A5		嫵 E8E4 370A	沛 E8F4 3CCD	灑 7067 7067	鉅 926E 926E	榭 6967 6967
1	嫻 SACE SACE	灑 E8A7 E8A7	璫 E8B7 3EE1	琊 E8C7 E8C7	琰 E8D5 E8D5	鐳 E8E5 E8E5	歷 E8F5 E8F5	峇 6CAF 6CAF	鎔 E915 493E	堦 E925 E925
2	娟 5A0B 5A0B	姁 5994 5994	璫 E8B8 E8B8	鉤 9284 9284	呢 E8D6 E8D6	璿 E8E6 E8E6	馥 E8F6 4A96	浓 E906 3CD6	韜 8F41 8F41	梁 E926 E926
3	紕 E899 42BC	焱 E8A9 E8A9	櫟 6AD8 6AD8	珣 73E6 73E6	摩 56A4 56A4	炸 59B0 59B0	懌 E8F7 398A	漾 E907 E907	鐳 E917 E917	登 E927 E927
4	熾 E89A E89A	靛 E8AA E8AA	璫 73F3 73F3	錕 935F 935F	溱 E8D8 E8D8	嫵 E8E8 E8E8	僞 50F4 50F4	溼 E908 E908	莖 E918 E918	桴 E928 E928
5	嬋 E89B 372C	緝 7DA8 7DA8	璫 73FB 73FB	鑫 E8CB E8CB	吡 E8D9 E8D9	媧 E8E9 E8E9	灑 E8F9 3D69	溼 6E02 6E02	焜 5812 5812	鎔 E929 E929
6	駢 E89C 4B7B	緝 E8AC E8AC	球 E8BC 3ED6	鑫 9331 9331	吡 E8DA E8DA	媧 E8EA E8EA	滙 E8FA 3D4C	溼 6F0C 6F0C	焜 57C8 57C8	桴 E92A E92A
7	鎊 E89D E89D	緝 E8AD E8AD	璫 E8BD E8BD	鑫 E8CD E8CD	峪 5502 5502	嫵 5AA1 5AA1	埔 E8FB E8FB	溼 E90B 3D6F	焜 E91B 36D6	杙 E92B E92B
8	鎖 93BB 93BB	瑱 E8AE E8AE	璫 E8BE E8BE	璫 E8CE E8CE	籽 79C4 79C4	媧 E8EC 36E2	焜 7175 7175	佩 E90C E90C	墩 E91C E91C	晴 E92C E92C
9	鑄 93B8 93B8	璫 E8AF E8AF	媧 E8BF E8BF	鎊 9386 9386	媧 E8DD E8DD	媧 E8ED E8ED	緝 E8FD 42FB	焜 7551 7551	焜 70FE 70FE	桴 6A1A 6A1A
A	嫵 E8A0 E8A0	鑄 E8B0 E8B0	璫 E8C0 E8C0	鑄 E8D0 E8D0	纏 7DFE 7DFE	媧 E8EE 36B0	躬 E8FE E8FE	媧 E90E 36BC	焜 E91E E91E	桴 E92E E92E
B	嚙 E8A1 E8A1	鎊 92E5 92E5	嚙 E8C1 E8C1	礮 E8D1 E8D1	媧 E8DF E8DF	鉅 925F 925F	洵 6E0F 6E0F	洵 E90F 34C8	鑿 E91F E91F	蒞 E92F E92F
C	蓁 8472 8472	琅 73E2 73E2	璫 E8C2 E8C2	銜 E8D2 4935	璫 E8E0 E8E0	媧 5A79 5A79	零 E900 E900	靚 E910 4680	焜 E920 E920	蓋 843E 843E
D	蓁 E8A3 E8A3	璫 E8B3 3EE9	璫 E8C3 E8C3	銜 E8D3 E8D3	璫 E8E1 E8E1	鑄 E8F1 E8F1	萁 E901 44EB	璫 E911 3EDA	埤 E921 E921	蒞 E931 44DF
E	壕 E8A4 E8A4	璫 74B4 74B4	璫 7448 7448	焜 716B 716B	藪 E8E2 452E	媧 E8F2 E8F2	洵 6D57 6D57	輻 E912 4871	汲 E922 E922	葯 E932 44CE
F	焜 E8A5 E8A5	鑄 E8B5 E8B5	璫 E8C5 E8C5		鋸 9401 9401	鑄 9374 9374	贖 E903 E903	媧 59C4 59C4	焜 68B9 68B9	

	984	985	986	987	98A	98B	98C	98D	98E	98F
0	蓉 E933 E933	嫫 5A71 5A71	襁 E953 E953	焯 7133 7133		鎰 E981 E981	玗 E991 E991	戩 E9A1 3F0E	熙 7188 7188	壳 58F2 58F2
1	苕 E934 E934	嫫 E944 E944	爇 E954 E954	勳 E964 E964	音 5485 5485	馥 E982 E982	玗 73E1 73E1	犛 E9A2 3F53	嘞 5623 5623	砵 7818 7818
2	苕 E935 E935	焯 E945 E945	焯 E955 E955	焯 E965 3DA5	鎰 E973 E973	佶 4FC8 4FC8	玗 81F6 81F6	吹 7542 7542	西 8980 8980	点 70B9 70B9
3	蔞 E936 E936	媼 E946 372D	焯 711D 711D	氾 6CDF 6CDF	曦 E974 E974	翮 7FE7 7FE7	琬 E994 3ECA	晷 756D 756D	塩 5869 5869	砒 781C 781C
4	滯 6F17 6F17	媼 59EF 59EF	焯 E957 E957	勇 E967 E967	金 E975 E975	狍 72CD 72CD	鼎 770C 770C	畚 7572 7572	眈 E9B5 401D	斫 E9C5 40A8
5	蔞 E938 E938	媼 E948 E948	鋹 E958 E958	璿 E968 E968	圻 577E 577E	狍 7310 7310	琇 E996 3ED1	晷 758D 758D	睽 7743 7743	砒 7839 7839
6	苕 833D 833D	姪 E949 36C7	倨 4FB0 4FB0	縉 7E65 7E65	甸 E977 E977	謹 E987 E987	沢 6CA2 6CA2	疔 E9A7 3F7C	睽 E9B7 4039	砒 7847 7847
7	媼 E93A E93A	媼 718E 718E	倨 E95A E95A	姪 59EB 59EB	灤 E978 E978	狍 7338 7338	国 56FD 56FD	痲 75C8 75C8	条 6761 6761	研 7851 7851
8	落 83ED 83ED	錚 9390 9390	嶂 5CC2 5CC2	嶂 5D2F 5D2F	確 E979 3FE5	狍 7339 7339	域 7419 7419	痲 75DC 75DC	瞋 E9B9 4045	砒 7866 7866
9	媼 E93C E93C	媼 669A 669A	熾 E95C E95C	屨 E96C 3DF3	巖 E97A E97A	禧 E98A E98A	望 741E 741E	痲 E9AA 3FC0	啖 E9BA 35DB	藁 8448 8448
A	蘘 E93D E93D	媼 E94D E94D	熾 E95D E95D	彝 5F5C 5F5C	巖 E97B E97B	玗 7341 7341	玗 741F 741F	痲 764D 764D	瞋 7798 7798	磁 E9CB E9CB
B	媼 E93E E93E	媼 5A6E 5A6E	熾 E95E E95E	璿 E96E E96E	湯 7003 7003	玗 7348 7348	琬 E99C 3EE2	痲 E9AC 3FD7	晰 E9BC 406A	礪 7933 7933
C	媼 5989 5989	媼 5A2B 5A2B	檣 6A0C 6A0C	媼 E96F E96F	霽 E97D E97D	玗 E98D 3EA9	璿 E99D 3EF0	痲 7674 7674	瞋 E9BD 406F	枋 6803 6803
D	媼 5A82 5A82	媼 E950 E950	焯 E960 E960	縉 7DA4 7DA4	慊 5D70 5D70	調 E98E E98E	璿 E99E 3EF4	痲 E9AE 3FDC	属 5C5E 5C5E	確 7932 7932
E	媼 E941 E941	媼 6A2B 6A2B	埤 E961 E961	縉 8426 8426	玗 738F 738F	漱 906C 906C	歷 E99F 3EFA	癸 767A 767A	罌 77BE 77BE	袂 E9CF 4103
F	媼 5A61 5A61	溼 E952 E952	焯 70A6 70A6		穀 7CD3 7CD3	燧 71F5 71F5	瓓 74D3 74D3	昧 E9B0 E9B0	瞋 77CB 77CB	

	994	995	996	997	99A	99B	99C	99D	99E	99F
0	襍 E9D0 4109	筓 7B62 7B62	縵 7DCF 7DCF	焯 70A0 70A0		芄 82CA 82CA	藹 8510 8510	祢 88AE 88AE	跃 8DC3 8DC3	廷 8FC1 8FC1
1	禍 7991 7991	箴 7B6C 7B6C	緇 7DD4 7DD4	歎 80B7 80B7	頤 EA0F 4413	苟 82D8 82D8	菀 8538 8538	椅 88FF 88FF	昨 EA4F 47ED	迓 8FCA 8FCA
2	禡 7999 7999	筴 7B7B 7B7B	緜 7DD0 7DD0	肱 80E9 80E9	堺 583A 583A	茱 82FF 82FF	蕢 8552 8552	裒 8924 8924	佻 4EEE 4EEE	迕 8FCC 8FCC
3	辻 8FBB 8FBB	篡 7C12 7C12	績 7DFD 7DFD	眊 EA03 43ED	脬 817C 817C	莛 EA21 44B0	藪 EA31 453B	櫛 8947 8947	躡 8E3A 8E3A	遁 9033 9033
4	稻 7A06 7A06	籓 7C1B 7C1B	羹 7FAE 7FAE	胙 810C 810C	腴 8184 8184	茂 8357 8357	蔭 856F 856F	覘 8991 8991	嚙 55D8 55D8	馱 99C4 99C4
5	込 8FBC 8FBC	籴 E9E5 4260	羴 7FB4 7FB4	猪 732A 732A	膾 EA13 4425	險 9669 9669	溘 8570 8570	眚 EA43 EA43	朮 5754 5754	遠 EA63 48AD
6	稽 E9D6 4167	糗 E9E6 427A	犖 729F 729F	脰 810E 810E	腸 8193 8193	柗 698A 698A	葛 85E0 85E0	訕 8A29 8A29	躡 8E71 8E71	食 98E0 98E0
7	窑 7A91 7A91	类 7C7B 7C7B	翻 E9F7 4397	眊 8112 8112	膾 EA15 442D	萐 8405 8405	縻 EA35 4577	詆 8A38 8A38	囁 55F5 55F5	鈺 9213 9213
8	窳 E9D8 41B2	糗 7C9C 7C9C	糶 8020 8020	畠 7560 7560	齧 81A5 81A5	灼 70F5 70F5	虻 8672 8672	誕 8A94 8A94	躡 8EB0 8EB0	鈺 EA66 491E
9	窳 7ABC 7ABC	糗 E9E9 428C	糶 8025 8025	齧 8114 8114	掩 57EF 57EF	葑 8464 8464	蚶 8692 8692	諒 8AB4 8AB4	眺 EA57 4837	鈺 9228 9228
A	𠄎 8279 8279	棋 7CB8 7CB8	筴 7B39 7B39	豚 EA0A 4401	賺 81C1 81C1	惣 60E3 60E3	蚶 86B2 86B2	豨 8C51 8C51	害 8ECE 8ECE	鈺 9258 9258
B	竝 E9DB 41C4	糗 E9EB 4294	糶 802E 802E	脰 EA0B 3B39	馱 81E4 81E4	萐 8488 8488	虻 86EF 86EF	賁 8CD4 8CD4	軫 8EE2 8EE2	鈺 926B 926B
C	軒 7ACF 7ACF	糗 7CED 7CED	糶 8031 8031	脰 8156 8156	馱 8254 8254	萐 EA2A 4504	际 9645 9645	賃 8CF2 8CF2	軫 8EE4 8EE4	鈺 92B1 92B1
D	鈴 7ADB 7ADB	輸 8F93 8F93	联 8054 8054	脰 8159 8159	艶 EA1B 448F	莖 84BE 84BE	蝮 878B 878B	贓 8D1C 8D1C	軫 8EED 8EED	銜 92AE 92AE
E	醇 E9DE 41CF	焯 70C0 70C0	焯 E9FE 3DCC	脰 815A 815A	芦 82A6 82A6	葭 84E1 84E1	蟻 EA3C 4606	趁 EA4C 4798	帖 8EF2 8EF2	鋪 92BF 92BF
F	兩 4E21 4E21	咄 E9EF E9EF	垠 57B4 57B4		艷 8276 8276	萐 84F8 84F8	衛 EA3D 4617	莖 585F 585F	𠄎 8FB7 8FB7	

	9A4	9A5	9A6	9A7	9AA	9AB	9AC	9AD	9AE	9AF
0	鄒 92E3 92E3	鐾 EA7D 496A	顛 EA8D 4AE4	輝 EA9D 4B9D		騰 9EF1 9EF1	𠂇 EACB EACB	惧 60E7 60E7	嚇 EAE6 EAE6	齧 EAFB EAFB
1	犁 92EB 92EB	鏹 9454 9454	慘 60E8 60E8	驪 9A3C 9A3C	𦘔 9EFE 9EFE	驢 9EF8 9EF8	𧈧 EACC EACC	𦘔 EADC EADC	噤 EAEC EAEC	𠂇 5364 5364
2	鑄 92F3 92F3	鑷 9479 9479	颯 98B9 98B9	髻 9B0F 9B0F	噐 5650 5650	竈 7AC8 7AC8	块 5757 5757	嘶 567A 567A	𠂇 5C20 5C20	莠 84AD 84AD
3	鏡 92F4 92F4	錠 952D 952D	颯 EA90 4B19	窃 7A83 7A83	鵠 9D93 9D93	𧈧 9F44 9F44	焗 7173 7173	𦘔 EAE6 EAE6	𠂇 EAE6 EAE6	垓 EAFE EAFE
4	鍔 92FD 92FD	閔 95A2 95A2	殮 98F1 98F1	魴 9B69 9B69	𧈧 9DBD 9DBD	𧈧 EABF EABF	廬 EACF EACF	𦘔 EADF EADF	昏 5E0B 5E0B	墜 EAFF EAFF
5	認 9343 9343	閱 EA82 49A7	塆 5844 5844	𧈧 9B81 9B81	𧈧 9DC0 9DC0	倣 EAC0 EAC0	𧈧 EAD0 EAD0	𦘔 EAE0 EAE0	𠂇 EAF0 EAF0	埕 EB00 EB00
6	鏡 9384 9384	𠂇 95F4 95F4	𠂇 990E 990E	𧈧 9BDD 9BDD	𧈧 9DFC 9DFC	倣 EAC1 EAC1	𦘔 EAD1 EAD1	𦘔 EAE1 EAE1	𠂇 EAF1 EAF1	𠂇 8B81 8B81
7	鎮 93AD 93AD	𠂇 9633 9633	𠂇 9919 9919	𧈧 9BF1 9BF1	銀 94F6 94F6	𧈧 691A 691A	𦘔 546A 546A	𦘔 EAE2 EAE2	𠂇 EAF2 EAF2	𠂇 EB02 EB02
8	璽 EA75 4945	𠂇 EA85 49E5	𠂇 51B4 51B4	𧈧 9BF4 9BF4	𧈧 8FB6 8FB6	鈴 94C3 94C3	𦘔 EAD3 EAD3	𦘔 EAE3 EAE3	𠂇 671E 671E	𠂇 EB03 EB03
9	鏤 EA76 4951	𧈧 67A0 67A0	𧈧 991C 991C	𧈧 EAA6 4C6D	𧈧 9E7B 9E7B	𧈧 59AC 59AC	𦘔 EAD4 EAD4	𦘔 6955 6955	𠂇 EAF4 EAF4	𠂇 EB04 EB04
A	𧈧 9EBF 9EBF	𧈧 EA87 4A24	𧈧 9937 9937	𧈧 9C20 9C20	𧈧 9EAC 9EAC	𧈧 EAC5 EAC5	𦘔 549E 549E	𧈧 9C2F 9C2F	𠂇 EAF5 EAF5	𠂇 EB05 EB05
B	𧈧 9417 9417	𧈧 9740 9740	𧈧 9942 9942	𧈧 EAA8 376F	𧈧 9EB1 9EB1	𧈧 5840 5840	𦘔 EAD6 EAD6	𧈧 87A5 87A5	𠂇 EAF6 EAF6	𠂇 4E78 4E78
C	𧈧 5301 5301	𧈧 EA89 4A35	𧈧 995D 995D	𧈧 EAA9 EAA9	𧈧 9EBD 9EBD	𧈧 94C1 94C1	𦘔 EAD7 EAD7	𦘔 EAE7 EAE7	𠂇 EAF7 3647	𠂇 70BB 70BB
D	𧈧 941D 941D	𧈧 97B2 97B2	𧈧 9962 9962	𧈧 9D49 9D49	𧈧 9EC6 9EC6	𧈧 EAC8 37B9	𦘔 EAD8 EAD8	𦘔 EAE8 EAE8	𠂇 EAF8 EAF8	𠂇 EB08 EB08
E	𧈧 942D 942D	𧈧 97C2 97C2	𧈧 EA9B 4B70	𧈧 9C3A 9C3A	𧈧 94DC 94DC	𧈧 EAC9 EAC9	𦘔 EAD9 EAD9	𦘔 EAE9 EAE9	𠂇 EAF9 EAF9	𠂇 EB09 EB09
F	𧈧 943E 943E	𧈧 5654 5654	𧈧 99C5 99C5		𧈧 9EE2 9EE2	𧈧 EACA EACA	𦘔 EADA EADA	𦘔 EAEA EAEA	𠂇 EAF9 EAF9	

	9B4	9B5	9B6	9B7	9BA	9BB	9BC	9BD	9BE	9BF
0	窳 EB0A EB0A	粥 EB1A EB1A	揅 EB2A EB2A	標 5FB1 5FB1		爍 EB58 EB58	邁 EB68 EB68	剗 EB78 EB78	碛 EB88 EB88	璋 EB98 EB98
1	窳 EB0B EB0B	悞 EB1B EB1B		咬 6648 6648	楚 6918 6918	煉 EB59 EB59	驢 EB69 EB69	軟 8EDA 8EDA	祉 EB89 EB89	箏 EB99 EB99
2	后 EB0C EB0C	慤 EB1C EB1C	掇 EB2C EB2C	嘻 66BF 66BF	殷 EB4A EB4A	璿 EB5A EB5A	寓 EB6A 3762	屨 EB7A EB7A	璋 EB8A EB8A	箏 EB9A EB9A
3	冢 EB0D EB0D	愴 EB1D EB1D	揆 EB2D EB2D	詭 EB3D EB3D	祐 EB4B EB4B	涇 EB5B EB5B	絲 EB6B EB6B	劓 528F 528F	讖 EB8B 4718	咖 EB9B EB9B
4	屈 EB0E EB0E	苻 82FD 82FD	篋 EB2E EB2E	櫟 EB3E EB3E	紘 EB4C EB4C	澧 51D2 51D2	讓 8B5E 8B5E	圻 573F 573F	磻 EB8C EB8C	岱 57A1 57A1
5	嶸 EB0F EB0F	願 EB1F EB1F	揅 EB2F EB2F	樹 EB3F EB3F	漆 EB4D EB4D	澗 EB5D EB5D	鑄 EB6D EB6D	焯 7171 7171	礧 EB8D EB8D	煑 7151 7151
6	拏 62C3 62C3	成 EB20 EB20	掠 EB30 EB30	□	漚 EB4E EB4E	晏 599F 599F	□	瞽 EB7E EB7E	毬 EB8E EB8E	□
7	歲 EB11 EB11	咏 EB21 EB21	擗 EB31 EB31	琦 EB41 EB41	衡 EB4F EB4F	嶂 EB5F EB5F	獄 EB6F EB6F	砭 EB7F EB7F	珀 EB8F EB8F	縶 EB9F EB9F
8	嶠 EB12 EB12	覘 89A5 89A5	揅 EB32 EB32	□	亭 EB50 EB50	槩 EB60 3BBE	琰 EB70 EB70	溶 EB80 EB80	隸 EB90 EB90	颯 EBA0 EBA0
9	熇 7198 7198	絳 EB23 EB23	攜 EB33 EB33	棒 EB43 EB43	鄭 EB51 48D0	淳 EB61 EB61	礪 EB71 EB71	瓊 EB81 EB81	僭 5066 5066	適 9056 9056
A	柏 6855 6855	皐 8FA0 8FA0	敎 EB34 EB34	檣 EB44 EB44	頤 EB52 4AB8	爇 EB62 EB62	爇 7209 7209	噫 55BC 55BC	剗 EB92 34FB	縶 EBA2 EBA2
B	昇 EB15 EB15	拒 EB25 EB25	夔 EB35 EB35	□	瀟 EB53 EB53	變 EB63 EB63	齧 EB73 EB73	砌 EB83 EB83	杞 EB93 EB93	皦 EBA3 EBA3
C	槩 69E9 69E9	鞞 97B8 97B8	馘 EB36 EB36	衛 EB46 EB46	鉞 EB54 EB54	岱 5788 5788	啞 EB74 EB74	砧 EB84 EB84	□	譔 8B62 8B62
D	烤 EB17 36C8	械 EB27 EB27	鑿 EB37 EB37	堦 58B5 58B5	熙 EB55 EB55	掉 EB65 EB65	奧 5965 5965	芷 EB85 EB85	齏 EB95 EB95	玃 EBA5 EBA5
E	脣 EB18 EB18	頤 9847 9847	曬 EB38 EB38	聆 670E 670E	燿 EB56 EB56	舉 EB66 399B	瘠 EB76 EB76	□	賄 EB96 477C	猜 EBA6 EBA6
F	鸞 EB19 EB19	駸 9ABD 9ABD	枕 EB39 EB39		灑 EB57 EB57	玃 EB67 EB67	睨 EB77 EB77	傷 EB87 3473	鈺 EB97 EB97	

	9C4	9C5	9C6	9C7	9CA	9CB	9CC	9CD	9CE	9CF
0	崙 5D5B 5D5B	燈 6195 6195	翊 EBC7 EBC7	獬 EBD7 EBD7		蟠 EBF5 EBF5	賦 EC05 EC05	□	廂 53A2 53A2	釵 EC35 EC35
1	紗 EBA8 EBA8	媿 5A27 5A27	滕 EBC8 EBC8	旡 EBD8 EBD8	嫩 EBE6 371C	嗣 EBF6 EBF6	駟 EC06 EC06	梟 EC16 4CB7	蒨 EC26 EC26	嶸 5DAB 5DAB
2	□	晉 EBB9 EBB9	□	植 7983 7983	衡 EBE7 EBE7	蠹 8827 8827	褻 8943 8943	醢 EC17 EC17	鎗 93BF 93BF	琇 EC37 EC37
3	𪗇 EBAA EBAA	□	驪 EBCA EBCA	舩 EBDA EBDA	蕞 EBE8 EBE8	褻 88F5 88F5	襪 EC08 EC08	翎 EC18 EC18	梱 6836 6836	旃 65BE 65BE
4	𪗇 EBAB EBAB	嶻 56B9 56B9	范 7B42 7B42	苻 EBDB EBDB	虢 EBE9 EBE9	懂 EBF9 EBF9	親 EC09 EC09	諱 EC19 EC19	毓 975D 975D	楨 69D5 69D5
5	諄 8AEA 8AEA	爲 EBBC EBBC	霆 EBCC EBCC	崱 5D2C 5D2C	步 EBEA 3C54	廷 EBFA EBFA	囓 56D6 56D6	詐 EC1A EC1A	蹕 EC2A EC2A	𪗇 53D2 53D2
6	瓊 EBAD EBAD	𪗇 EBBD EBBD	卣 EBCD EBCD	楸 EBDD EBDD	蚶 EBEB EBEB	媿 EBFB EBFB	礮 EC0B 40DF	譏 EC1B EC1B	跽 EC2B EC2B	璵 EC3B EC3B
7	翮 EBAE EBAE	𪗇 4E6A 4E6A	𪗇 EBCE EBCE	□	𪗇 EBEC EBEC	溱 6EB8 6EB8	奮 EC0C EC0C	眈 EC1C EC1C	𪗇 EC2C EC2C	淇 EC3C EC3C
8	淺 EBAF EBAF	珏 EBBF EBBF	□	茫 EBDF EBDF	鉤 9281 9281	璨 EBFD EBFD	爍 EC0D 39A1	濫 EC1D EC1D	塲 EC2D EC2D	櫟 EC3D 3C11
9	𪗇 EBB0 EBB0	陵 9656 9656	𪗇 EBD0 EBD0	𪗇 EBE0 46D0	𪗇 EBEE EBEE	嫿 EBFE EBFE	檣 EC0E EC0E	筭 7B43 7B43	𪗇 EC2E EC2E	朶 6736 6736
A	𪗇 EBB1 4BC0	𪗇 6D8F 6D8F	穰 7A45 7A45	𪗇 EBE1 EBE1	𪗇 EBEF EBEF	𪗇 EBFF 39A4	𪗇 EC0F EC0F	𪗇 797E 797E	𪗇 EC2F EC2F	𪗇 EC3F EC3F
B	𪗇 EBB2 EBB2	𪗇 EBC2 EBC2	□	画 753B 753B	銖 9330 9330	𪗇 EC00 36B9	塹 EC10 EC10	𪗇 EC20 EC20	𪗇 5D85 5D85	𪗇 EC40 EC40
C	𪗇 EBB3 EBB3	𪗇 EBC3 3618	𪗇 EBD3 EBD3	𪗇 8865 8865	𪗇 EBF1 EBF1	□	𪗇 71AD 71AD	𪗇 6FB5 6FB5	𪗇 EC31 EC31	𪗇 EC41 EC41
D	𪗇 EBB4 EBB4	𪗇 8977 8977	𪗇 9A26 9A26	𪗇 EBE4 EBE4	𪗇 EBF2 EBF2	□	𪗇 8366 8366	𪗇 EC22 EC22	𪗇 EC32 EC32	𪗇 EC42 EC42
E	𪗇 9465 9465	𪗇 EBC5 EBC5	𪗇 EBD5 EBD5	𪗇 58B6 58B6	𪗇 6C39 6C39	𪗇 EC03 453F	𪗇 EC13 EC13	𪗇 6A03 6A03	𪗇 5715 5715	𪗇 EC43 EC43
F	𪗇 EBB6 EBB6	𪗇 EBC6 EBC6	𪗇 EBD6 365F		𪗇 949F 949F	𪗇 66B6 66B6	𪗇 EC14 EC14	𪗇 EC24 EC24	𪗇 9823 9823	

	9D4	9D5	9D6	9D7	9DA	9DB	9DC	9DD	9DE	9DF
0	躡 EC44 EC44	錄 EC54 EC54	运 8FD0 8FD0	纛 7E9F 7E9F		踈 EC92 EC92	預 5B6D 5B6D	嘍 561E 561E	曖 77B9 77B9	嗶 55F1 55F1
1	躡 EC45 EC45	肭 EC55 43DF	犏 728F 728F	鯁 EC75 EC75	辺 8FBA 8FBA	鐳 EC93 EC93	漪 ECA3 ECA3	鐳 7F49 7F49	鋈 9345 9345	甲 66F1 66F1
2	𪗇 EC46 EC46	𪗈 EC56 EC56	𪗉 568B 568B	𪗊 EC76 EC76	𪗋 EC84 EC84	𪗌 EC94 EC94	𪗍 ECA4 ECA4	𪗎 ECB4 ECB4	𪗏 5432 5432	𪗐 ECD4 ECD4
3	𪗑 EC47 EC47	𪗒 EC57 EC57	𪗓 EC67 EC67	𪗔 EC77 4CA4	𪗕 8FB9 8FB9	𪗖 EC95 EC95	𪗗 63DE 63DE	𪗘 5975 5975	𪗙 8148 8148	𪗚 ECD5 362D
4	𪗛 EC48 EC48	𪗜 EC58 EC58	𪗝 EC68 EC68	𪗞 9547 9547	𪗟 EC86 EC86	𪗠 EC96 EC96	𪗡 □	𪗢 ECB6 ECB6	𪗣 82F7 82F7	𪗤 7534 7534
5	𪗧 EC49 EC49	𪗨 59F8 59F8	𪗩 EC69 EC69	𪗪 EC79 EC79	𪗫 EC87 4509	𪗬 EC97 3DEB	𪗭 ECA7 ECA7	𪗮 8770 8770	𪗯 5625 5625	𪗰 55F0 55F0
6	𪗲 EC4A 35CA	𪗳 EC5A EC5A	𪗴 EC6A EC6A	𪗵 71A2 71A2	𪗶 7E7F 7E7F	𪗷 EC98 EC98	𪗸 ECA8 ECA8	𪗹 4E1C 4E1C	𪗺 8132 8132	𪗻 55BA 55BA
7	𪗽 EC4B EC4B	𪗾 □	𪗿 EC6B EC6B	𪘀 EC7B EC7B	𪘁 6F56 6F56	𪘂 EC99 EC99	𪘃 6530 6530	𪘄 ECB9 ECB9	𪘅 8418 8418	𪘆 5497 5497
8	𪘈 EC4C EC4C	𪘉 EC5C EC5C	𪘊 EC6C EC6C	𪘋 EC7C 4D91	𪘌 6AB1 6AB1	𪘍 EC9A EC9A	𪘎 562D 562D	𪘏 ECBA ECBA	𪘐 80BD 80BD	𪘑 5572 5572
9	𪘔 EC4D 48FA	𪘕 EC5D EC5D	𪘖 EC6D EC6D	𪘗 9012 9012	𪘘 4EEA 4EEA	𪘙 EC9B EC9B	𪘚 ECAB ECAB	𪘛 ECBB ECBB	𪘜 55EA 55EA	𪘝 ECDB ECDB
A	𪘿 63E6 63E6	𪙀 □	𪙁 EC6E EC6E	𪙂 EC7E EC7E	𪙃 EC8C 34E4	𪙄 4E9A 4E9A	𪙅 541A 541A	𪙆 8117 8117	𪙇 7962 7962	𪙈 ECDC ECDC
B	𪙊 EC4F EC4F	𪙋 EC5F EC5F	𪙌 EC6F EC6F	𪙍 EC7F 4D9C	𪙎 EC8D EC8D	𪙏 EC9D EC9D	𪙐 ECAD ECAD	𪙑 9D5E 9D5E	𪙒 5643 5643	𪙓 5ED0 5ED0
C	𪙖 7808 7808	𪙗 EC60 EC60	𪙘 EC70 EC70	𪙙 EC80 EC80	𪙚 EC8E EC8E	𪙛 EC9E EC9E	𪙜 ECAE 3DC6	𪙝 8D18 8D18	𪙞 5416 5416	𪙟 ECDE ECDE
D	𪙡 9255 9255	𪙢 EC61 3DF7	𪙣 EC71 EC71	𪙤 8FBE 8FBE	𪙥 EC8F 373A	𪙦 56BF 56BF	𪙧 ECAE ECAE	𪙨 763B 763B	𪙩 ECCF ECCF	𪙪 ECDF ECDF
E	𪙬 EC52 EC52	𪙭 EC62 EC62	𪙮 EC72 EC72	𪙯 55C1 55C1	𪙰 8E80 8E80	𪙱 ECA0 ECA0	𪙲 ECB0 4C7D	𪙳 9C45 9C45	𪙴 ECD0 35CE	𪙵 ECE0 ECE0
F	𪙷 EC53 43F2	𪙸 EC63 EC63	𪙹 EC73 EC73		𪙺 EC91 EC91	𪙻 8E0E 8E0E	𪙼 5622 5622	𪙽 764E 764E	𪙾 5605 5605	

	9E4	9E5	9E6	9E7	9EA	9EB	9EC	9ED	9EE	9EF
0	喙 ECE1 ECE1	蠟 9C72 9C72	衲 88C7 88C7	蝟 ED11 ED11		織 7E8E 7E8E	吠 544B 544B	鴿 ED4F ED4F	鳧 ED5F ED5F	斬 ED6F 37FB
1	麪 9EAB 9EAB	攪 ECF2 ECF2	潤 81B6 81B6	酰 9170 9170	鱗 9C5D 9C5D	鴉 9D50 9D50	堦 57AA 57AA	藝 845C 845C	瘡 7640 7640	窻 6119 6119
2	緬 7D5A 7D5A	冫 519A 519A	蛄 841C 841C	困 ED13 ED13	攬 651F 651F	业 4E1A 4E1A	竦 ED41 ED41	深 ED51 ED51	嫩 5AF0 5AF0	航 ED71 ED71
3	磁 55DE 55DE	剋 ECF4 34DF	靦 ED04 ED04	鈇 9208 9208	擗 ED22 ED22	上 4E04 4E04	鷗 ED42 ED42	蛭 ED52 ED52	訥 ED62 ED62	熿 ED72 ED72
4	嚟 ECE5 ECE5	啞 ECF5 ECF5	葦 ED05 44EC	深 ED15 ED15	醅 ED23 48F3	咱 ED33 3577	□	脬 ED53 ED53	啄 787A 787A	□
5	拘 629D 629D	𠂔 51A7 51A7	獠 7304 7304	嚙 ED16 ED16	狷 ED24 ED24	媾 5B0D 5B0D	搽 ED44 3A52	檉 ED54 ED54	趨 ED64 47B6	嚙 565D 565D
6	靱 976D 976D	呶 544D 544D	籠 ED07 ED07	呷 ED17 ED17	鮫 ED25 ED25	淹 6CB2 6CB2	彙 ED45 ED45	梯 632E 632E	墻 58A7 58A7	垤 ED75 ED75
7	咋 5494 5494	啣 551E 551E	宀 5B90 5B90	啖 ED18 ED18	嚙 ED26 ED26	卧 5367 5367	獠 7374 7374	紮 7D25 7D25	碯 ED66 40BF	垤 57A7 57A7
8	脏 8CCD 8CCD	啤 5513 5513	芪 830B 830B	牦 7266 7266	啖 ED27 ED27	姁 ED37 36AC	鮠 ED47 ED47	澗 ED57 ED57	噤 567C 567C	琬 ED77 ED77
9	煨 71F6 71F6	癭 7666 7666	臙 ED0A ED0A	𠂔 ED1A ED1A	□	拮 ED38 39DC	鸚 ED48 4D09	沼 ED58 ED58	鮠 9B8B 9B8B	鮪 ED78 ED78
A	酶 9176 9176	踴 8E2D 8E2D	噤 567B 567B	𠂔 ED1B 474E	蠟 ED29 ED29	卽 537D 537D	𩺰 9BED 9BED	擗 ED59 3A2A	嶠 5D74 5D74	剝 5234 5234
B	揅 63FC 63FC	曝 ECFC ECFC	慄 ED0C ED0C	𠂔 ED1C ED1C	滑 ED2A ED2A	奸 ED3A 36A5	𩺰 ED4A ED4A	迫 9008 9008	瘳 7654 7654	靜 ED7A ED7A
C	搯 63B9 63B9	庖 75B1 75B1	𠂔 ED0D ED0D	𠂔 ED1D ED1D	□	扣 ED3B ED3B	𩺰 ED4B ED4B	勑 52CC 52CC	駐 ED6B ED6B	𠂔 ED7B 35AD
D	搯 63FE 63FE	𠂔 80B6 80B6	焮 ED0E ED0E	𠂔 ED1E ED1E	控 ED2C ED2C	𩺰 589A 589A	𩺰 ED4C 4C5B	狻 ED5C 3E74	麇 9E85 9E85	□
E	啣 5569 5569	螭 8804 8804	𠂔 ED0F ED0F	𠂔 ED1F 40FA	𠂔 ED2D ED2D	𩺰 ED3D ED3D	𩺰 ED4D ED4D	墻 ED5D 367A	𩺰 ED6D 4CE1	𩺰 9D7C 9D7C
F	𠂔 ECF0 ECF0	螭 8786 8786	𠂔 ED10 ED10		燿 71A3 71A3	𩺰 822D 822D	𩺰 ED4E ED4E	𩺰 ED5E 45E9	□	

	9F4	9F5	9F6	9F7	9FA	9FB	9FC	9FD	9FE	9FF
0	籤 7C56 7C56	嶠 ED8E ED8E	□	熯 EDAE 3E06		酖 915C 915C	□	氹 6C31 6C31	颯 98B4 98B4	跣 8DD4 8DD4
1	鬻 9B39 9B39	蔚 5D8E 5D8E	篩 7C42 7C42	勑 52D1 52D1	植 692C 692C	□	璉 EDDD EDDD	伏 EDED EDED	骷 9ABA 9ABA	蹠 8E4F 8E4F
2	埵 57DE 57DE	霽 9703 9703	炒 7C86 7C86	垢 5767 5767	段 53DA 53DA	酈 9151 9151	盖 76D6 76D6	但 4F39 4F39	麩 9EA8 9EA8	鸚 9E1C 9E1C
3	媵 ED81 ED81	炭 ED91 ED91	鰕 9C15 9C15	偕 5056 5056	鯨 9C0A 9C0A	陡 EDCF EDCF	養 9B9D 9B9D	吃 549C 549C	龕 9E84 9E84	踉 8E01 8E01
4	肩 5C53 5C53	龕 9E81 9E81	筓 7BFC 7BFC	妣 59B7 59B7	鳩 9D02 9D02	棲 637F 637F	个 4E2A 4E2A	噪 54DA 54DA	煨 717A 717A	扛 6282 6282
5	攄 64D3 64D3	遑 904C 904C	髮 9B09 9B09	岱 5E12 5E12	斂 EDC1 4C3B	蕪 EDD1 EDD1	哂 EDE1 EDE1	劓 529A 529A	笔 7B14 7B14	輾 EE11 EE11
6	頰 ED84 ED84	箴 7B1F 7B1F	□	鞞 97C8 97C8	阬 9641 9641	櫛 6ACA 6ACA	莽 83BE 83BE	趲 8D82 8D82	□	蹤 8E28 8E28
7	囀 ED85 ED85	鬢 9B02 9B02	鯁 9C1B 9C1B	鶻 9DAB 9DAB	楸 6980 6980	嘑 5611 5611	衄 8842 8842	嘍 EDF3 35FE	揄 6BFA 6BFA	蹇 8E75 8E75
8	贛 ED86 ED86	峯 5CD1 5CD1	玨 EDA6 EDA6	輻 8F5C 8F5C	僭 50A6 50A6	馘 918E 918E	□	□	蠟 8818 8818	蚝 7AD3 7AD3
9	蛄 86AD 86AD	筈 7BA3 7BA3	齧 9F5A 9F5A	哧 5469 5469	畝 7546 7546	薑 757A 757A	届 5C4A 5C4A	嗒 EDF5 35F3	罨 7F78 7F78	璿 EE15 EE15
A	喧 ED88 ED88	扌 6268 6268	啖 5573 5573	鞞 97B4 97B4	娟 EDC6 EDC6	拘 6285 6285	稟 69C0 69C0	□	□	稟 7A3E 7A3E
B	蒞 ED89 ED89	拚 6335 6335	冤 5BC3 5BC3	餽 9940 9940	駛 99DA 99DA	儻 EDD7 EDD7	□	敵 6B52 6B52	嘎 5620 5620	磻 78D8 78D8
C	璫 ED8A ED8A	鬚 9AFF 9AFF	倣 4FFD 4FFD	鞞 97BA 97BA	劓 5273 5273	獾 734F 734F	垓 577A 577A	醜 917C 917C	齏 EE08 EE08	汨 6CEA 6CEA
D	啖 ED8B ED8B	箴 7BCF 7BCF	馨 9E98 9E98	匱 532C 532C	□	簠 7C70 7C70	劓 521F 521F	顛 9FA5 9FA5	蹙 8E77 8E77	簪 8A67 8A67
E	□	鬪 9B2A 9B2A	劓 4FF2 4FF2	愧 6130 6130	斟 9159 9159	箴 EDDA EDDA	卮 5DF5 5DF5	鮫 9B97 9B97	亂 9F53 9F53	瘡 7607 7607
F	囑 51FE 51FE	糲 7C7E 7C7E	剌 5260 5260		隄 9681 9681	泐 EDDB EDDB	从 4ECE 4ECE	頰 982E 982E	□	

	A04	A05	A06	A07	A0A	A0B	A0C	A0D	A0E	A0F
0	銛 EE1B EE1B	蕩 862F 862F	鮓 9B8F 9B8F	麩 9E96 9E96		糲 7CC2 7CC2	脍 8103 8103	埤 EE89 3635	佻 6077 6077	蕒 EEA9 EEA9
1	鮠 9F26 9F26	僥 5FBA 5FBA	𧈧 87F5 87F5	憾 617D 617D	歲 5D57 5D57	糲 EE6A EE6A	昵 7724 7724	楹 69B2 69B2	□	蕒 EEAA EEAA
2	汜 6CCE 6CCE	裘 88A0 88A0	□	□	鑲 EE5B EE5B	糲 7CDA 7CDA	羈 8989 8989	趨 8DA6 8DA6	罟 7F71 7F71	崑 5CC1 5CC1
3	𧈧 87D6 87D6	苦 EE2E 44B7	□	坟 575F 575F	迎 8FDA 8FDA	稽 7A2D 7A2D	脹 EE7C EE7C	□	鎬 EE9C EE9C	縶 EEAC EEAC
4	疝 75C3 75C3	□	賈 8CF7 8CF7	傷 616F 616F	阨 EE5D EE5D	聰 8066 8066	奮 7553 7553	覩 89A9 89A9	□	鍤 EEAD EEAD
5	麿 EE20 EE20	媯 EE30 EE30	狷 732C 732C	捫 62A6 62A6	□	睨 8063 8063	諫 EE7E EE7E	□	懲 60E9 60E9	榉 EEAE EEAE
6	砗 7853 7853	蔻 EE31 EE31	霹 9721 9721	𠂔 6239 6239	僨 50D9 50D9	紕 7D4D 7D4D	螻 87A9 87A9	倭 6DB9 6DB9	馱 EE9F 4B7E	𠂔 EEAF EEAF
7	𠂔 EE22 EE22	□	鮑 9BB0 9BB0	□	屺 EE60 EE60	𠂔 7505 7505	蝻 87CE 87CE	蟲 87C1 87C1	刪 5220 5220	臄 EEB0 EEB0
8	𠂔 8DOC 8DOC	詢 8A7E 8A7E	啗 EE43 35D6	搯 EE53 3A5C	礮 7906 7906	𠂔 74F2 74F2	臄 81C8 81C8	瀆 EE91 EE91	櫛 EEA1 EEA1	癩 EEB1 EEB1
9	狍 72E2 72E2	倅 EE34 EE34	狃 72B2 72B2	𠂔 61E2 61E2	𠂔 5332 5332	覓 8994 8994	蟹 878C 878C	𠂔 74E7 74E7	𠂔 EEA2 EEA2	𠂔 EEB2 4562
A	獮 7371 7371	□	髻 EE45 4C07	厖 53AA 53AA	阨 9638 9638	𠂔 821A 821A	誼 8A49 8A49	保 EE93 3DDB	糲 EEA3 EEA3	蟻 5B1F 5B1F
B	𠂔 8B2D 8B2D	愠 60FD 60FD	𠂔 7C51 7C51	𠂔 EE56 EE56	𠂔 EE64 EE64	盼 670C 670C	質 8CAD 8CAD	焜 7176 7176	𠂔 EEA4 EEA4	𠂔 EEB4 EEB4
C	狎 7302 7302	癩 7667 7667	𠂔 994A 994A	捥 6364 6364	𠂔 EE65 4065	𠂔 8062 8062	謔 8B43 8B43	忽 60A4 60A4	𠂔 EEA5 EEA5	𠂔 9F50 9F50
D	𠂔 74F1 74F1	𠂔 9AD7 9AD7	綏 EE48 EE48	𠂔 6802 6802	□	𠂔 EE76 EE76	𠂔 772B 772B	𠂔 619C 619C	𠂔 EEA6 EEA6	𠂔 9EA6 9EA6
E	賈 8CEB 8CEB	鷄 9D44 9D44	慙 6159 6159	𠂔 EE59 35D2	𠂔 77FE 77FE	𠂔 805B 805B	𠂔 74F8 74F8	𠂔 EE97 3CD1	𠂔 EEA7 EEA7	𠂔 EEB7 EEB7
F	璿 EE2A EE2A	鍤 936E 936E	𠂔 EE4A 4C04		□	𠂔 74F0 74F0	𠂔 84DA 84DA	□	𠂔 EEA8 EEA8	

8140-8DFE (UDA3)

	814	815	816	817	81A	81B	81C	81D	81E	81F
0										
1										
2										
3										
4										
5										
6										
7										
8										
9										
A										
B										
C										
D										
E										
F										

	824	825	826	827	82A	82B	82C	82D	82E	82F
0										
1										
2										
3										
4										
5										
6										
7										
8										
9										
A										
B										
C										
D										
E										
F										

	834	835	836	837	83A	83B	83C	83D	83E	83F
0										
1										
2										
3										
4										
5										
6										
7										
8										
9										
A										
B										
C										
D										
E										
F										

	844	845	846	847	84A	84B	84C	84D	84E	84F
0										
1										
2										
3										
4										
5										
6										
7										
8										
9										
A										
B										
C										
D										
E										
F										

	854	855	856	857	85A	85B	85C	85D	85E	85F
0										
1										
2										
3										
4										
5										
6										
7										
8										
9										
A										
B										
C										
D										
E										
F										

	864	865	866	867	86A	86B	86C	86D	86E	86F
0										
1										
2										
3										
4										
5										
6										
7										
8										
9										
A										
B										
C										
D										
E										
F										

	874	875	876	877	87A	87B	87C	87D	87E	87F
0										
1										
2										
3										
4										
5										
6										
7										
8										
9										
A										
B										
C										
D										
E										
F										

	884	885	886	887	88A	88B	88C	88D	88E	88F
0	✓ F303 F303	ℓ F313 F313	Ö 01D1 01D1	ī 012B 012B						
1) F304 F304	Ʒ F314 F314	Ò 00D2 00D2	í 00ED 00ED	ü 01DC 01DC					
2	ℓ F305 F305	Ʒ F315 F315	Ē F325 F325	ï 01D0 01D0	ü 00FC 00FC					
3	↷ F306 F306	Ʒ F316 F316	Ē 1EBE 1EBE	ì 00EC 00EC	ē F344 F344					
4	ℓ F307 F307	ℓ F317 F317	Ē F327 F327	ō 014D 014D	ē 1EBF 1EBF					
5	ℓ F308 F308	ℓ F318 F318	Ē 1EC0 1EC0	ó 00F3 00F3	ē F346 F346					
6	ℓ F309 F309	Ā 0100 0100	Ē 00CA 00CA	ö 01D2 01D2	ē 1EC1 1EC1					
7	ℓ F30A F30A	Ā 00C1 00C1	ā 0101 0101	ò 00F2 00F2	ê 00EA 00EA					
8	⌋ F30B F30B	Ă 01CD 01CD	ă 00E1 00E1	ū 016B 016B	g 0261 0261					
9	⌋ F30C F30C	Ă 00C0 00C0	ă 01CE 01CE	ú 00FA 00FA	≡ F34A F34A					
A	↷ F30D F30D	Ē 0112 0112	à 00E0 00E0	ÿ 01D4 01D4	⊞ F34B F34B					
B	↷ F30E F30E	É 00C9 00C9	á 0251 0251	ÿ 00F9 00F9						
C	↷ F30F F30F	Ē 011A 011A	ē 0113 0113	ÿ 01D6 01D6						
D	ℓ F310 F310	È 00C8 00C8	é 00E9 00E9	ÿ 01D8 01D8						
E	ℓ F311 F311	Ō 014C 014C	ě 011B 011B	ÿ 01DA 01DA						
F	ℓ F312 F312	Ō 00D3 00D3	ě 00E8 00E8							

	894	895	896	897	89A	89B	89C	89D	89E	89F
0	鷹 F3A0 F3A0	侨 4FA8 4FA8	头 5934 5934	纺 7EBA 7EBA		贗 8D0B 8D0B		龜 4E80 4E80	囫 51FC 51FC	呱 5493 5493
1	嚙 F3A1 F3A1	充 5156 5156	学 5B66 5B66	织 7EC7 7EC7	瑣 7411 7411	胶 80F6 80F6	溶 6E9A 6E9A	孑 4E87 4E87	办 5205 5205	咭 54A3 54A3
2		兴 5174 5174	实 5B9E 5B9E	经 7ECF 7ECF	幼 7CFC 7CFC	鹵 F3F0 F3F0	晒 823E 823E	亿 4EBF 4EBF	争 4E89 4E89	呱 54B4 54B4
3	攪 650A 650A	农 519C 519C	奕 5B9F 5B9F	统 7EDF 7EDF	緡 7DCD 7DCD		貳 7519 7519	仝 4EEB 4EEB	剝 5279 5279	啞 54B9 54B9
4		凤 51E4 51E4	岚 5C9A 5C9A	缆 7F06 7F06	櫻 6946 6946			佻 4F37 4F37	薊 5290 5290	啞 54D0 54D0
5		务 52A1 52A1	庆 5E86 5E86	卸 7F37 7F37	寵 7AC9 7AC9	肱 809F 809F	醜 F403 4911	佢 F413 344C	爽 5327 5327	哏 54EF 54EF
6	丽 4E3D 4E3D	动 52A8 52A8	总 603B 603B	艺 827A 827A	劫 5227 5227	黠 9EC7 9EC7	马 9A6C 9A6C	俣 4FBD 4FBD	暇 F424 35C7	啓 5518 5518
7	滝 6EDD 6EDD	医 533B 533B	齐 6589 6589	苏 82CF 82CF		鸚 F3F5 4CCD	骏 9A8F 9A8F	犖 F415 3E48	厩 53A9 53A9	哞 5523 5523
8	鷄 9D4E 9D4E	华 534E 534E	枉 67FE 67FE	药 836F 836F		鷓 9DC9 9DC9	龙 9F99 9F99	俗 5003 5003	厨 F426 3551	咀 5528 5528
9	钷 91DF 91DF	发 53D1 53D1	荣 6804 6804	视 89C6 89C6		鸛 9E0C 9E0C	褚 7987 7987	凜 5088 5088	廠 53B0 53B0	哞 F437 3598
A		变 53D8 53D8	桥 6865 6865	设 8BBE 8BBE		鯽 F3F8 4C3E	逝 F408 F408	儻 F418 347D	厩 F428 3553	唞 553F 553F
B		团 56E2 56E2	济 6D4E 6D4E	询 8BE2 8BE2	醜 918C 918C	鮫 F3F9 F3F9	島 F409 F409	健 F419 3493	参 53C2 53C2	啞 F439 35A5
C	帶 F3AC F3AC	声 58F0 58F0	炼 70BC 70BC	车 8F66 8F66	颯 78B8 78B8	菁 F3FA F3FA	浯 F40A F40A	儻 F41A 34A5	心 5423 5423	哪 F43A 35BF
D	撐 6491 6491	处 5904 5904	电 7535 7535	轧 8F67 8F67	酖 915E 915E	鸚 9E0A 9E0A	拊 F40B F40B	円 5186 5186	吠 F42B 356D	嚼 55D7 55D7
E	会 4F1A 4F1A	备 5907 5907	纤 7EA4 7EA4	轮 8F6E 8F6E	胼 80BC 80BC	鷄 F3FC F3FC	两 4E24 4E24	犖 5905 5905	味 F42C 3572	啞 F43C 35C5
F	佻 4F28 4F28	夆 5932 5932	纬 7EAC 7EAC			嚙 F3FD 35C1	乾 4E81 4E81	凜 51DB 51DB	繞 F42D 3681	

	8A4	8A5	8A6	8A7	8AA	8AB	8AC	8AD	8AE	8AF
0	𥇏 F43D F43D	搗 F44D F44D	擻 F45D F45D	𥇏 F46D F46D		搗 F48B F48B	𥇏 F49B F49B	𥇏 F4AB 3992	𥇏 F4BB F4BB	𥇏 F4CB 3F93
1	𥇏 5525 5525	擻 F44E 3A34	𥇏 F45E F45E	𥇏 F46E F46E	𥇏 F47C F47C		搗 6379 6379	𥇏 F4AC 3A06	𥇏 F4BC F4BC	𥇏 F4CC F4CC
2		𥇏 F44F 47D5	𥇏 F45F F45F	搗 F46F F46F	𥇏 F47D F47D	𥇏 F48D F48D	𥇏 F49D 39FE	𥇏 F4AD F4AD	𥇏 F4BD F4BD	𥇏 F4CD F4CD
3	𥇏 F440 F440	𥇏 F450 F450		𥇏 9D6E 9D6E	𥇏 F47E F47E	𥇏 F48E F48E	𥇏 F49E F49E	𥇏 F4AE 3578	𥇏 F4BE F4BE	𥇏 F4CE F4CE
4	𥇏 F441 F441	𥇏 F451 F451	𥇏 F461 F461	𥇏 9815 9815	𥇏 64EA 64EA	𥇏 F48F F48F	𥇏 8DC0 8DC0	𥇏 F4AF F4AF	𥇏 F4BF F4BF	𥇏 F4CF F4CF
5	𥇏 F442 F442	𥇏 F452 F452	𥇏 F462 F462		𥇏 F480 F480	𥇏 F490 F490	𥇏 56A1 56A1	𥇏 F4B0 F4B0	𥇏 F4C0 F4C0	
6	𥇏 5590 5590	𥇏 64DD 64DD	𥇏 F463 F463	𥇏 F473 43D9	𥇏 F481 F481	𥇏 F491 F491	𥇏 647C 647C	𥇏 5652 5652	𥇏 F4C1 F4C1	𥇏 F4D1 F4D1
7	𥇏 F444 F444	𥇏 F454 F454	𥇏 F464 47F4	𥇏 F474 F474	𥇏 8E68 8E68	𥇏 5579 5579	𥇏 F4A2 3E43	𥇏 F4B2 F4B2	𥇏 7F93 7F93	𥇏 F4D2 F4D2
8	𥇏 F445 39EC	𥇏 F455 F455	𥇏 F465 F465	𥇏 64B4 64B4	𥇏 F483 F483	𥇏 F493 40BB		𥇏 F4B3 F4B3	𥇏 F4C3 F4C3	𥇏 F4D3 F4D3
9	𥇏 F446 F446	𥇏 F456 F456	𥇏 F466 F466	𥇏 54E3 54E3	𥇏 F484 F484	𥇏 F494 43BA	𥇏 F4A4 F4A4	𥇏 F4B4 F4B4	𥇏 F4C4 F4C4	𥇏 F4D4 F4D4
A	𥇏 8E46 8E46	𥇏 F457 F457	𥇏 9AB2 9AB2	𥇏 F477 F477	𥇏 F485 F485		𥇏 F4A5 F4A5	𥇏 F4B5 34BC	𥇏 F4C5 F4C5	𥇏 F4D5 F4D5
B	𥇏 F448 F448	𥇏 648D 648D	𥇏 F468 3A67	𥇏 F478 F478		𥇏 F496 4AB4	𥇏 F4A6 F4A6	𥇏 6C3D 6C3D	𥇏 F4C6 35FB	𥇏 F4D6 3FF9
C	𥇏 F449 F449	𥇏 8E7E 8E7E	𥇏 F469 F469	𥇏 F479 F479	𥇏 F487 480B	𥇏 F497 F497	𥇏 F4A7 F4A7	𥇏 F4B7 F4B7	𥇏 F4C7 F4C7	𥇏 F4D7 F4D7
D	𥇏 F44A 4053	𥇏 F45A F45A	𥇏 F46A 3FED	𥇏 F47A 39FB	𥇏 F488 F488	𥇏 F498 F498			𥇏 F4C8 F4C8	𥇏 6432 6432
E	𥇏 F44B F44B	𥇏 F45B F45B	𥇏 F46B 3506	𥇏 F47B F47B	𥇏 F489 3FFA	𥇏 81AA 81AA	𥇏 F4A9 F4A9		𥇏 F4C9 F4C9	𥇏 F4D9 F4D9
F	𥇏 777A 777A	𥇏 F45C F45C	𥇏 F46C F46C		𥇏 5873 5873	𥇏 98F5 98F5	𥇏 F4AA F4AA	𥇏 F4BA F4BA	𥇏 F4CA F4CA	

	8B4	8B5	8B6	8B7	8BA	8BB	8BC	8BD	8BE	8BF
0	𣎵 F4DA F4DA	𣎵 95AA 95AA	尿 F4FA 3797	唵 F50A F50A		割 5268 5268	丨 4E28 4E28	彳 6C35 6C35	聿 8080 8080	风 98CE 98CE
1	袂 F4DB F4DB	哌 54CC 54CC	吓 535F 535F	𦉳 F50B F50B	𦉳 F519 F519	𦉳 F529 361A	𦉳 5902 5902	𦉳 6C3A 6C3A	聿 F559 F559	飞 98DE 98DE
2	揸 F4DC F4DC	𦉳 82C4 82C4	𦉳 F4FC F4FC	𦉳 F50C F50C	𦉳 F51A F51A	𦉳 F52A F52A	𦉳 F53A F53A	𦉳 706C 706C	𦉳 F55A F55A	𦉳 9963 9963
3	𦉳 F4DD F4DD	𦉳 55B9 55B9	𦉳 91B6 91B6	𦉳 F50D F50D	𦉳 F51B F51B	𦉳 7BB2 7BB2	𦉳 F53B F53B	𦉳 722B 722B	𦉳 535D 535D	𦉳 F56B F56B
4	𦉳 F4DE F4DE		𦉳 F4FE F4FE	𦉳 F50E F50E	𦉳 F51C F51C	𦉳 5B68 5B68	𦉳 9751 9751	𦉳 4E2C 4E2C	𦉳 8864 8864	𦉳 9C7C 9C7C
5	揸 F4DF F4DF	𦉳 F4EF F4EF	𦉳 F4FF F4FF	𦉳 F50F F50F	𦉳 F51D F51D	𦉳 F52D 4800	𦉳 F53D F53D	𦉳 72AD 72AD	𦉳 89C1 89C1	𦉳 9E1F 9E1F
6	揸 F4E0 F4E0	𦉳 9C26 9C26	𦉳 F500 F500	𦉳 F510 F510	𦉳 F51E 3703	𦉳 F52E 4B2C	𦉳 4E5B 4E5B	𦉳 F54E F54E	𦉳 F55E F55E	𦉳 9EC4 9EC4
7	揸 F4E1 3A18	𦉳 9AB6 9AB6	𦉳 F501 F501	𦉳 F511 F511	𦉳 F51F F51F	𦉳 9F27 9F27	𦉳 4EBB 4EBB	𦉳 7F52 7F52	𦉳 8BA0 8BA0	𦉳 6B6F 6B6F
8	𦉳 F4E2 F4E2	𦉳 F4F2 F4F2	𦉳 F502 35DD	𦉳 5A54 5A54	𦉳 F520 F520	𦉳 F530 49E7	𦉳 F540 353E	𦉳 793B 793B	𦉳 8D1D 8D1D	𦉳 9F9C 9F9C
9	𦉳 F4E3 F4E3	𦉳 F4F3 F4F3	𦉳 F503 F503	𦉳 F513 F513	𦉳 F521 F521	𦉳 9C1F 9C1F	𦉳 5C23 5C23	𦉳 7CF9 7CF9	𦉳 9485 9485	𦉳 4E37 4E37
A	𦉳 F4E4 F4E4	𦉳 7140 7140	𦉳 F504 3609	𦉳 F514 F514	𦉳 F522 F522	𦉳 9B8D 9B8D	𦉳 5F51 5F51	𦉳 7F53 7F53	𦉳 9578 9578	𦉳 F572 F572
B	𦉳 F4E5 F4E5	𦉳 816D 816D	𦉳 F505 F505	𦉳 F515 F515	𦉳 F523 F523	𦉳 F533 F533	𦉳 5FC4 5FC4	𦉳 F553 F553	𦉳 957F 957F	𦉳 961D 961D
C	𦉳 F4E6 F4E6	𦉳 80EC 80EC	𦉳 56AF 56AF	𦉳 F516 F516	𦉳 F524 F524	𦉳 F534 F534	𦉳 F544 38FA	𦉳 F554 34C1	𦉳 95E8 95E8	𦉳 6237 6237
D	𦉳 F4E7 F4E7	𦉳 5C1C 5C1C	𦉳 F507 F507	𦉳 579C 579C	𦉳 F525 F525	𦉳 55FB 55FB	𦉳 624C 624C		𦉳 F565 F565	𦉳 94A2 94A2
E	𦉳 F4E8 F4E8	𦉳 F4F8 F4F8	𦉳 F508 F508	𦉳 F518 F518	𦉳 F526 F526	𦉳 F536 35F2	𦉳 6535 6535	𦉳 F556 F556	𦉳 97E6 97E6	
F	𦉳 F4E9 F4E9	𦉳 8134 8134	𦉳 F509 F509		𦉳 5899 5899	𦉳 5689 5689	𦉳 6B7A 6B7A	𦉳 8002 8002	𦉳 9875 9875	

	8C4	8C5	8C6	8C7	8CA	8CB	8CC	8CD	8CE	8CF
0										
1										
2										
3										
4										
5										
6										
7										
8										
9										
A										
B										
C										
D										
E										
F										

	8D4	8D5	8D6	8D7	8DA	8DB	8DC	8DD	8DE	8DF
0			嶮 5D3E 5D3E	愼 F644 394D		晷 F662 3AF2	櫛 6964 6964	櫛 6AF6 6AF6	温 6E29 6E29	漈 F6A2 3D75
1			暖 5D48 5D48	愼 60D7 60D7	捰 F653 3A03	晷 6692 6692	捰 699F 699F	歿 6B81 6B81	淑 6E86 6E86	燿 71B7 71B7
2			嶮 5D56 5D56	博 613D 613D	搭 63E2 63E2	曦 F664 3B22	榘 6985 6985	毀 6BC1 6BC1	鉏 F694 F694	舂 5C99 5C99
3			蕪 F637 3DFC	崢 5CE5 5CE5	撼 63FB 63FB	腺 6716 6716	榘 F675 3BBC	毳 6BEA 6BEA	溺 6EBB 6EBB	灑 F6A5 3D8A
4			嶮 F638 380F	愼 F648 3989	揅 6407 6407	杓 F666 3B42	橐 69D6 69D6	泠 6C75 6C75	滢 6EE2 6EE2	灑 702C 702C
5			嶮 5DA4 5DA4	愼 61B7 61B7	揅 645A 645A	杖 67A4 67A4	櫛 F677 3BDD	沪 6CAA 6CAA	滾 6EDA 6EDA	漱 F6A7 3D91
6			嶮 5DB9 5DB9	懷 61B9 61B9	擗 F658 3A4B	梔 6800 6800	槩 6A65 6A65	沂 F688 3CCB	齿 9F7F 9F7F	澄 7050 7050
7			嶮 F63B 3820	愼 61CF 61CF	擗 64C0 64C0	拾 F669 3B58	櫛 6A74 6A74	泌 6D02 6D02	滨 6EE8 6EE8	灑 7054 7054
8			帙 F63C 3838	戟 F64C 39B8	崕 5D15 5D15	荼 684A 684A	榭 6A71 6A71	涿 6D06 6D06	滩 6EE9 6EE9	灯 706F 706F
9			冪 5E42 5E42	戩 622C 622C	摐 5621 5621	栖 6884 6884	穰 6A82 6A82	洎 6D26 6D26	溲 6F24 6F24	灿 707F 707F
A			廌 5EBD 5EBD	捩 6290 6290	龟 9F9F 9F9F	裕 F66C 3B72	羴 F67C 3BEC	淞 6D81 6D81	滌 6F34 6F34	炉 7089 7089
B			弥 5F25 5F25	拥 62E5 62E5	敲 F65D 3A97	榭 F66D 3B71	榭 6A99 6A99	淬 F68D 3CEF	濇 F69D 3D46	雉 F6AD F6AD
C			徃 5F83 5F83	撈 6318 6318	斨 6586 6586	梢 F66E 3B7B	檠 F67E 3BF2	淦 6DA4 6DA4	溲 F69E F69E	睥 F6AE 43C1
D			忼 F641 3908	捰 F651 39F8	昕 F65F 3ABD	棗 6909 6909	檠 6AAB 6AAB	浪 6DB1 6DB1	澁 6F81 6F81	噤 F6AF 35F1
E			忼 F642 3914	噤 56B1 56B1	昨 65FF 65FF	握 6943 6943	檠 6AB5 6AB5	洎 6E15 6E15	澁 6FBE 6FBE	喙 F6B0 F6B0
F			掩 F643 393F		晓 6653 6653	牛 725C 725C	檠 6AD4 6AD4	涿 6E18 6E18	漾 F6A1 3D6A	











C6A1-C8FE (VDA)

					C6A	C6B	C6C	C6D	C6E	C6F
0						(6) 2479 2479	丿 4E3F 4E3F	ㄣ 5F50 5F50	々 3005 3005	お 304A 304A
1					① 2460 2460	(7) 247A 247A	丿 4E85 4E85	彡 5F61 5F61	ノ 3006 3006	か 304B 304B
2					② 2461 2461	(8) 247B 247B	一 4EA0 4EA0	支 6534 6534	○ 3007 3007	が 304C 304C
3					③ 2462 2462	(9) 247C 247C	冂 5182 5182		一 30FC 30FC	き 304D 304D
4					④ 2463 2463	(10) 247D 247D	一 5196 5196	疒 7592 7592	[FF3B FF3B	ぎ 304E 304E
5					⑤ 2464 2464	i 2170 2170	彡 51AB 51AB] FF3D FF3D	く 304F 304F
6					⑥ 2465 2465	ii 2171 2171	勺 52F9 52F9	辵 8FB5 8FB5	* 273D 273D	ぐ 3050 3050
7					⑦ 2466 2466	iii 2172 2172	匚 5338 5338		あ 3041 3041	け 3051 3051
8					⑧ 2467 2467	iv 2173 2173	冂 5369 5369	〃 00A8 00A8	あ 3042 3042	げ 3052 3052
9					⑨ 2468 2468	v 2174 2174	厶 53B6 53B6	^ 02C6 02C6	い 3043 3043	こ 3053 3053
A					⑩ 2469 2469	vi 2175 2175	夕 590A 590A	、 30FD 30FD	い 3044 3044	ご 3054 3054
B					(1) 2474 2474	vii 2176 2176	宀 5B80 5B80	、 30FE 30FE	う 3045 3045	さ 3055 3055
C					(2) 2475 2475	viii 2177 2177	≪≪≪ 5DDB 5DDB	、 309D 309D	う 3046 3046	ざ 3056 3056
D					(3) 2476 2476	ix 2178 2178	彡 F6DD 2F33	、 309E 309E	え 3047 3047	し 3057 3057
E					(4) 2477 2477	x 2179 2179	广 5E7F 5E7F		え 3048 3048	じ 3058 3058
F					(5) 2478 2478	、 4E36 4E36			お 3049 3049	

	C74	C75	C76	C77	C7A	C7B	C7C	C7D	C7E	C7F
0	す 3059 3059	ど 3069 3069	べ 3079 3079	ら 3089 3089		ゴ 30B4 30B4	ツ 30C4 30C4	ピ [◦] 30D4 30D4	ヤ 30E4 30E4	ヴ 30F4 30F4
1	ず 305A 305A	な 306A 306A	ぺ 307A 307A	り 308A 308A	ウ 30A5 30A5	サ 30B5 30B5	ヅ 30C5 30C5	フ 30D5 30D5	ユ 30E5 30E5	カ 30F5 30F5
2	せ 305B 305B	に 306B 306B	ほ 307B 307B	る 308B 308B	ウ 30A6 30A6	ザ 30B6 30B6	テ 30C6 30C6	ブ 30D6 30D6	ユ 30E6 30E6	ケ 30F6 30F6
3	ぜ 305C 305C	ぬ 306C 306C	ぼ 307C 307C	れ 308C 308C	エ 30A7 30A7	シ 30B7 30B7	デ 30C7 30C7	プ [◦] 30D7 30D7	ヨ 30E7 30E7	Α 0410 0410
4	そ 305D 305D	ね 306D 306D	ぽ 307D 307D	ろ 308D 308D	エ 30A8 30A8	ジ 30B8 30B8	ト 30C8 30C8	ヘ 30D8 30D8	ヨ 30E8 30E8	Б 0411 0411
5	ぞ 305E 305E	の 306E 306E	ま 307E 307E	わ 308E 308E	オ 30A9 30A9	ス 30B9 30B9	ド 30C9 30C9	ベ 30D9 30D9	ラ 30E9 30E9	В 0412 0412
6	た 305F 305F	は 306F 306F	み 307F 307F	わ 308F 308F	オ 30AA 30AA	ズ 30BA 30BA	ナ 30CA 30CA	ペ [◦] 30DA 30DA	リ 30EA 30EA	Г 0413 0413
7	だ 3060 3060	ば 3070 3070	む 3080 3080	る 3090 3090	カ 30AB 30AB	セ 30BB 30BB	ニ 30CB 30CB	ホ 30DB 30DB	ル 30EB 30EB	Д 0414 0414
8	ち 3061 3061	ぱ [◦] 3071 3071	め 3081 3081	ゑ 3091 3091	ガ 30AC 30AC	ゼ 30BC 30BC	ヌ 30CC 30CC	ボ 30DC 30DC	レ 30EC 30EC	Е 0415 0415
9	ぢ 3062 3062	ひ 3072 3072	も 3082 3082	を 3092 3092	キ 30AD 30AD	ソ 30BD 30BD	ネ 30CD 30CD	ポ [◦] 30DD 30DD	ロ 30ED 30ED	Ё 0401 0401
A	っ 3063 3063	び 3073 3073	や 3083 3083	ん 3093 3093	ギ 30AE 30AE	ゾ 30BE 30BE	ノ 30CE 30CE	マ 30DE 30DE	ワ 30EE 30EE	Ж 0416 0416
B	っ 3064 3064	ぴ [◦] 3074 3074	や 3084 3084	ア 30A1 30A1	ク 30AF 30AF	タ 30BF 30BF	ハ 30CF 30CF	ミ 30DF 30DF	ワ 30EF 30EF	З 0417 0417
C	づ 3065 3065	ふ 3075 3075	ゆ 3085 3085	ア 30A2 30A2	グ 30B0 30B0	ダ 30C0 30C0	バ 30D0 30D0	ム 30E0 30E0	ヰ 30F0 30F0	И 0418 0418
D	て 3066 3066	ぶ 3076 3076	ゆ 3086 3086	イ 30A3 30A3	ケ 30B1 30B1	チ 30C1 30C1	パ 30D1 30D1	メ 30E1 30E1	ヱ 30F1 30F1	Й 0419 0419
E	で 3067 3067	ぶ [◦] 3077 3077	よ 3087 3087	イ 30A4 30A4	ゲ 30B2 30B2	ヂ 30C2 30C2	ヒ 30D2 30D2	モ 30E2 30E2	ヲ 30F2 30F2	К 041A 041A
F	と 3068 3068	へ 3078 3078	よ 3088 3088		コ 30B3 30B3	ツ 30C3 30C3	ビ 30D3 30D3	ヤ 30E3 30E3	ン 30F3 30F3	

	C84	C85	C86	C87	C8A	C8B	C8C	C8D	C8E	C8F
0	Л 041B 041B	Ы 042B 042B	К 043A 043A	Ъ 044A 044A				” FF02 FF02	月 F82A 2E9D	倉 F83A 2EDE
1	М 041C 041C	Ь 042C 042C	Л 043B 043B	Ы 044B 044B	ㄣ F7EB F7EB			(株) 3231 3231	𠂇 F82B 2EA5	骨 F83B 2EE3
2	Н 041D 041D	Э 042D 042D	М 043C 043C	Ь 044C 044C	ㄨ 5188 5188			No. 2116 2116	生 F82C 2EA7	
3	О 041E 041E	Ю 042E 042E	Н 043D 043D	Э 044D 044D	ㄨ F7ED F7ED			Tel 2121 2121	正 F82D 2EAA	
4	П 041F 041F	Я 042F 042F	О 043E 043E	Ю 044E 044E	ㄣ F7EE F7EE			” 309B 309B	𠂇 F82E 2EAC	
5	Р 0420 0420	а 0430 0430	П 043F 043F	Я 044F 044F				° 309C 309C	𠂇 F82F 2EAE	∫ 0283 0283
6	С 0421 0421	б 0431 0431	р 0440 0440	↑ 21E7 21E7				ゝ F820 2E80	𠂇 F830 2EB6	Ꞥ 0250 0250
7	Т 0422 0422	В 0432 0432	С 0441 0441	↖ 21B8 21B8				𠂇 F821 2E84	月 F831 2EBC	ε 025B 025B
8	У 0423 0423	Г 0433 0433	Т 0442 0442	↔ 21B9 21B9				𠂇 F822 2E86	𠂇 F832 2EBE	Ꞥ 0254 0254
9	Ф 0424 0424	Д 0434 0434	У 0443 0443	↘ F7E5 F7E5				𠂇 F823 2E87	角 F833 2EC6	θ 0275 0275
A	Х 0425 0425	е 0435 0435	ф 0444 0444	𠂇 F7E6 F7E6				𠂇 F824 2E88	𠂇 F834 2ECA	œ 0153 0153
B	Ц 0426 0426	ё 0451 0451	х 0445 0445	ㄣ 4E5A 4E5A				𠂇 F825 2E8A	𠂇 F835 2ECC	ø 00F8 00F8
C	Ч 0427 0427	ж 0436 0436	ц 0446 0446	ク F7E8 F7E8				𠂇 F826 2E8C	𠂇 F836 2ECD	ŋ 014B 014B
D	Ш 0428 0428	З 0437 0437	ч 0447 0447	𠂇 5202 5202			𠂇 FFE2 FFE2	𠂇 F827 2E8D	𠂇 F837 2ECF	Û 028A 028A
E	Щ 0429 0429	И 0438 0438	ш 0448 0448	𠂇 F7EA F7EA			𠂇 FFE4 FFE4	𠂇 F828 2E95	𠂇 F838 2ED6	ı 026A 026A
F	Ъ 042A 042A	Й 0439 0439	Ш 0449 0449				’ FF07 FF07	𠂇 F829 2E9C	𠂇 F839 2ED7	

F9D6-F9FE (VDA)

								F9D	F9E	F9F
0									 2560 2560	 2565 2565
1									 256C 256C	 2556 2556
2									 2563 2563	 255F 255F
3									 255A 255A	 256B 256B
4									 2569 2569	 2562 2562
5									 255D 255D	 2559 2559
6								碁 7881 7881	 2552 2552	 2568 2568
7								锈 92B9 92B9	 2564 2564	 255C 255C
8								裏 88CF 88CF	 2555 2555	 2551 2551
9								墙 58BB 58BB	 255E 255E	 2550 2550
A								恒 6052 6052	 256A 256A	 256D 256D
B								粧 7CA7 7CA7	 2561 2561	 256E 256E
C								媚 5AFA 5AFA	 2558 2558	 2570 2570
D								 2554 2554	 2567 2567	 256F 256F
E								 2566 2566	 255B 255B	 FFED FFED
F								 2557 2557	 2553 2553	

Section 3 Code Allocation of the HKSCS in ISO 10646

- 3.1 ISO 10646 is an international coding standard developed under the aegis of the International Organisation for Standardisation (ISO) which aims at developing one single common character set encompassing characters and symbols used in all major languages in the world. ISO 10646 v1.0 was published in 1993, with 20 902 ideographic characters. The next version, ISO 10646 v2.0, which is an extension to ISO 10646 v1.0, is expected to be published in 2000. ISO 10646 v2.0 will consist of more than 6 500 additional ideographic characters defined in the Extension A, the complete set of Kang Xi radicals and other symbols and characters.

- 3.2 Characters in the HKSCS which are already defined in ISO 10646 are mapped to their corresponding code points in ISO 10646. Characters in the HKSCS which are not yet defined in ISO 10646 are assigned code points in the Private Use Area (PUA) of ISO 10646 in the range of E000 – F8FF.

- 3.3 The diagram below shows the code blocks of ISO 10646 in relation to the HKSCS. The names of the code blocks are given for ease of reference only and may not be the same as the terms used in the ISO 10646 standard document.

00	FF
00	Alphabet Block (Number of HKSCS characters: 123)
20	General Symbol Block (Number of HKSCS characters: 69)
2E	Kang Xi Radicals Block Characters defined in this block are only available in ISO 10646 v2.0 (Number HKSCS characters: 29)
30	CJK Symbol Block (Number of HKSCS characters: 180)
34	Extension A Block Characters defined in this block are only available in ISO 10646 v2.0 (Number of HKSCS characters: 498)
4E	CJK Ideographic Block (Number of HKSCS characters: 2 148)
A0
E0	Private Use Area (Number of HKSCS characters: 2 175 for ISO 10646 v1.0 and 1 648 for ISO 10646 v2.0)
F8
FE	Compatibility Block (Number of HKSCS characters: 7)
FF	

Alphabet Block : All alphabets used in languages such as English and French.

General Symbol Block : General symbols such as punctuation marks, currency signs and geometrical shapes.

Kang Xi Radical Block : All radicals in the Kang Xi Dictionary for inclusion in ISO 10646 v2.0.

CJK Symbol Block : For ideograph-related phonetics and symbols such as Japanese Hiragana and Katakana, and Chinese punctuation marks.

Extension A Block: Extension to the CJK ideographic block. Committed by ISO for inclusion in ISO 10646 v2.0.

CJK Ideographic Block : Chinese-Japanese-Korean ideographs.

Private Use Area: Reserved for individuals and vendors for their specific requirements. There are 6 400 code points available in this block.

Compatibility Block: An area for compatibility with ISO's base standards where characters and their variant forms are both coded in the base standards especially for half-width and full-width characters.

3.4 In some existing ISO 10646-enabled systems, the code points in the UDAs of Big-5 are directly mapped to the PUA of ISO 10646 although some of the GCCS characters concerned are already defined in ISO 10646. In order to maintain backward compatibility with such systems, the PUA code points of those HKSCS characters which are already defined in ISO 10646 are not reassigned to other characters and are reserved as compatibility points. The compatibility points can also maintain backward compatibility between ISO 10646 v2.0 and ISO 10646 v1.0 when some of the HKSCS characters defined in the PUA of ISO 10646 v1.0 become standard characters in ISO 10646 v2.0.

3.5 The Big-5 code range 8140 – 84FE in UDA3, which is reserved for the public, has a corresponding code range EEB8 – F12B in the PUA of ISO 10646 for compatibility purpose. This PUA block will not be occupied by future extensions of the HKSCS. It is open to the public for their private use. The following is a diagram showing this PUA block:

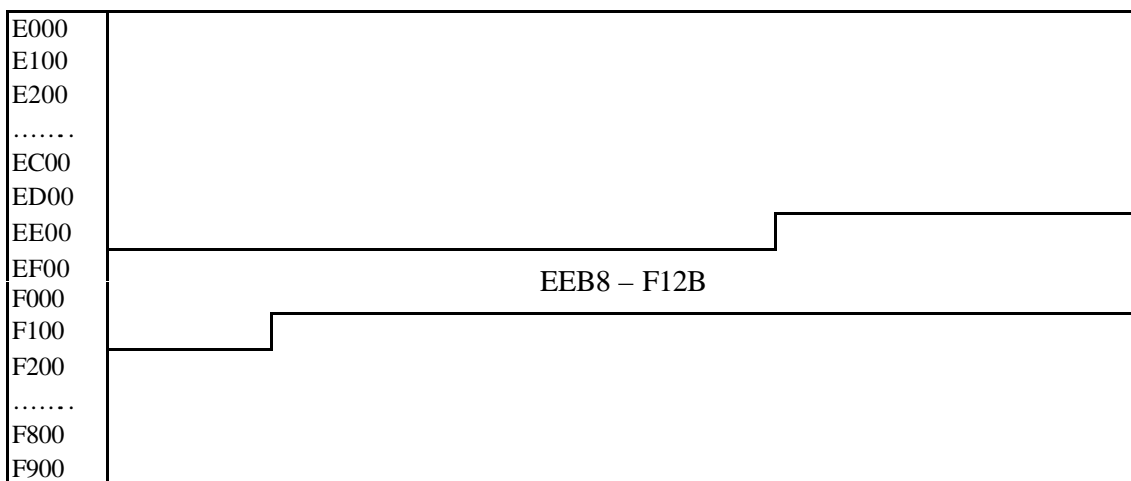

3.6 Tables 3.1 and 3.2 show the code point assignment of the HKSCS in the PUA of ISO 10646 v1.0 and ISO 10646 v2.0 respectively. Each cell in the tables represents a single code point. The code point value is the column code concatenated with the row code. These two tables also show the corresponding Big-5 codes of the characters. The compatibility points and their corresponding characters in ISO 10646 v1.0 and ISO 10646

v2.0 are listed at Annex II and Annex III respectively. Tables 3.3 and 3.4 show the ISO 10646/Big-5 mapping for the HKSCS characters which are already defined in ISO 10646 v1.0 and ISO 10646 v2.0 respectively.

Table 3.1 – Code Table of the HKSCS in the PUA of ISO 10646 v1.0

The following is an example of a typical cell in this table:

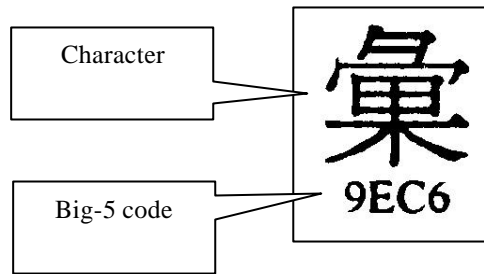

The following is an example of a cell representing a compatibility point in this table:

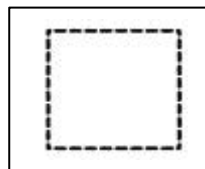

	E00	E01	E02	E03	E04	E05	E06	E07	E08	E09	E0A	E0B	E0C	E0D	E0E	E0F
0	宥 FA40		優 FA60	丕 FA70			匯 FAC2				鵬 FB43			壬 FB73		
1							滙 FAC3	却 FAD3								姸 FBB6
2	逸 FA42	玳 FA52	傑 FA62	呔 FA72									姪 FB65		咕 FBA7	亞 FBB7
3	瀟 FA43	鈞 FA53	傑 FA63	帽 FA73	淋 FAA5					苈 FAF5			苻 FB66		蕓 FBA8	
4		佻 FA54		倂 FA74			咍 FAC6	卿 FAD6		唎 FAF6				鷄 FB77	菴 FBA9	嫫 FBB9
5	紉 FA45	茆 FA55	僚 FA65	循 FA75	礙 FAA7			侯 FAD7					墜 FB68	焜 FB78	媵 FBAA	
6		僂 FA56		𦉳 FA76			婁 FAC8		𦉳 FAE8		嫫 FB49					
7				𦉳 FA77					𦉳 FAE9		滂 FB4A		𦉳 FB6A	𦉳 FB7A	媵 FBAC	
8	𦉳 FA48	後 FA58	僂 FA68	孛 FA78				鏹 FADA		超 FAFA	藁 FB4B		燿 FB6B		媵 FBAD	𦉳 FBBD
9	𦉳 FA49								𦉳 FAEB	𦉳 FAFB	𦉳 FB4C				𦉳 FBAE	𦉳 FBBE
A	𦉳 FA4A	𦉳 FA5A				𦉳 FABC	𦉳 FACC		𦉳 FAEC	𦉳 FAFC		𦉳 FB5D	𦉳 FB6D	𦉳 FB7D		𦉳 FBBF
B		𦉳 FA5B	𦉳 FA6B	𦉳 FA7B			𦉳 FACD			𦉳 FAFD	𦉳 FB4E	𦉳 FB5E			𦉳 FBB0	𦉳 FBC0
C	𦉳 FA4C	𦉳 FA5C		𦉳 FA7C	𦉳 FAAE	𦉳 FABE	𦉳 FACE		𦉳 FAEE	𦉳 FAFE		𦉳 FB5F		𦉳 FBA1	𦉳 FBB1	𦉳 FBC1
D		𦉳 FA5D	𦉳 FA6D					𦉳 FADF		𦉳 FB40			𦉳 FB70			𦉳 FBC2
E	𦉳 FA4E	𦉳 FA5E	𦉳 FA6E				𦉳 FAD0	𦉳 FAE0		𦉳 FB41	𦉳 FB51	𦉳 FB61			𦉳 FBB3	
F						滙 FAC1								奮 FBA4		

	E10	E11	E12	E13	E14	E15	E16	E17	E18	E19	E1A	E1B	E1C	E1D	E1E	E1F
0	<input type="checkbox"/>	𪗇 FBD5	<input type="checkbox"/>	𪗈 FBF5	<input type="checkbox"/>	𪗉 FC56	𪗊 FC66	<input type="checkbox"/>	𪗋 FCA8	𪗌 FCB8	𪗍 FCC8	𪗎 FCD8	<input type="checkbox"/>	<input type="checkbox"/>	𪗏 FD49	𪗐 FD59
1	<input type="checkbox"/>	<input type="checkbox"/>	𪗑 FBE6	𪗒 FBF6	𪗓 FC47	<input type="checkbox"/>	<input type="checkbox"/>	𪗔 FC77	<input type="checkbox"/>	<input type="checkbox"/>	<input type="checkbox"/>	𪗕 FCD9	𪗖 FCE9	<input type="checkbox"/>	𪗗 FD4A	<input type="checkbox"/>
2	<input type="checkbox"/>	<input type="checkbox"/>	<input type="checkbox"/>	<input type="checkbox"/>	𪗘 FC48	<input type="checkbox"/>	𪗙 FC68	𪗚 FC78	<input type="checkbox"/>	<input type="checkbox"/>	<input type="checkbox"/>	<input type="checkbox"/>	<input type="checkbox"/>	<input type="checkbox"/>	𪗛 FD4B	𪗜 FD5B
3	𪗝 FBC8	<input type="checkbox"/>	<input type="checkbox"/>	<input type="checkbox"/>	𪗞 FC49	𪗟 FC59	<input type="checkbox"/>	<input type="checkbox"/>	<input type="checkbox"/>	𪗠 FCBB	<input type="checkbox"/>	𪗡 FCDB	<input type="checkbox"/>	<input type="checkbox"/>	𪗢 FD4C	<input type="checkbox"/>
4	𪗣 FBC9	𪗤 FBD9	<input type="checkbox"/>	<input type="checkbox"/>	𪗥 FC4A	𪗦 FC5A	𪗧 FC6A	<input type="checkbox"/>	<input type="checkbox"/>	<input type="checkbox"/>	𪗨 FCCC	𪗩 FCDC	𪗪 FCEC	𪗫 FCFC	<input type="checkbox"/>	𪗬 FD5D
5	𪗭 FBCA	𪗮 FBDA	𪗯 FBEA	<input type="checkbox"/>	𪗰 FC4B	𪗱 FC5B	<input type="checkbox"/>	𪗲 FC7B	𪗳 FCAD	𪗴 FCBD	<input type="checkbox"/>	<input type="checkbox"/>	𪗵 FCED	𪗶 FCFD	<input type="checkbox"/>	<input type="checkbox"/>
6	𪗷 FBCB	<input type="checkbox"/>	𪗸 FBEB	𪗹 FBFB	<input type="checkbox"/>	𪗺 FC5C	<input type="checkbox"/>	<input type="checkbox"/>	<input type="checkbox"/>	𪗻 FCBE	𪗼 FCCE	𪗽 FCDE	𪗾 FCEE	<input type="checkbox"/>	𪗿 FD4F	<input type="checkbox"/>
7	<input type="checkbox"/>	𪗿 FBDC	𪗽 FBEC	<input type="checkbox"/>	𪗾 FC4D	𪗿 FC5D	<input type="checkbox"/>	<input type="checkbox"/>	𪗽 FCAF	<input type="checkbox"/>	𪗾 FCCF	<input type="checkbox"/>	<input type="checkbox"/>	𪗾 FD40	𪗾 FD50	𪗾 FD60
8	<input type="checkbox"/>	<input type="checkbox"/>	𪗾 FBED	<input type="checkbox"/>	𪗾 FC4E	<input type="checkbox"/>	𪗾 FC6E	𪗾 FC7E	<input type="checkbox"/>	<input type="checkbox"/>	<input type="checkbox"/>	𪗾 FCE0	𪗾 FCF0	<input type="checkbox"/>	<input type="checkbox"/>	𪗾 FD61
9	𪗾 FBCE	<input type="checkbox"/>	<input type="checkbox"/>	𪗾 FBFE	<input type="checkbox"/>	𪗾 FC5F	𪗾 FC6F	𪗾 FCA1	𪗾 FCB1	<input type="checkbox"/>	𪗾 FCD1	<input type="checkbox"/>	<input type="checkbox"/>	<input type="checkbox"/>	<input type="checkbox"/>	<input type="checkbox"/>
A	𪗾 FBCF	<input type="checkbox"/>	𪗾 FBEF	<input type="checkbox"/>	𪗾 FC50	𪗾 FC60	𪗾 FC70	<input type="checkbox"/>	<input type="checkbox"/>	𪗾 FCC2	𪗾 FCD2	<input type="checkbox"/>	<input type="checkbox"/>	𪗾 FD43	𪗾 FD53	𪗾 FD63
B	𪗾 FBD0	<input type="checkbox"/>	𪗾 FBF0	<input type="checkbox"/>	<input type="checkbox"/>	<input type="checkbox"/>	<input type="checkbox"/>	𪗾 FCA3	𪗾 FCB3	<input type="checkbox"/>	<input type="checkbox"/>	𪗾 FCE3	<input type="checkbox"/>	<input type="checkbox"/>	𪗾 FD54	<input type="checkbox"/>
C	<input type="checkbox"/>	𪗾 FBE1	<input type="checkbox"/>	𪗾 FC42	<input type="checkbox"/>	<input type="checkbox"/>	<input type="checkbox"/>	𪗾 FCA4	𪗾 FCB4	𪗾 FCC4	<input type="checkbox"/>	𪗾 FCE4	𪗾 FCF4	<input type="checkbox"/>	<input type="checkbox"/>	<input type="checkbox"/>
D	<input type="checkbox"/>	𪗾 FBE2	<input type="checkbox"/>	<input type="checkbox"/>	𪗾 FC53	𪗾 FC63	<input type="checkbox"/>	<input type="checkbox"/>	<input type="checkbox"/>	<input type="checkbox"/>	<input type="checkbox"/>	𪗾 FCE5	𪗾 FCF5	𪗾 FD46	<input type="checkbox"/>	<input type="checkbox"/>
E	𪗾 FBD3	<input type="checkbox"/>	<input type="checkbox"/>	<input type="checkbox"/>	<input type="checkbox"/>	𪗾 FC64	<input type="checkbox"/>	𪗾 FCA6	<input type="checkbox"/>	<input type="checkbox"/>	𪗾 FCD6	𪗾 FCE6	<input type="checkbox"/>	<input type="checkbox"/>	<input type="checkbox"/>	𪗾 FD67
F	<input type="checkbox"/>	<input type="checkbox"/>	<input type="checkbox"/>	<input type="checkbox"/>	<input type="checkbox"/>	𪗾 FC65	<input type="checkbox"/>	𪗾 FCA7	𪗾 FCB7	𪗾 FCC7	<input type="checkbox"/>	𪗾 FCE7	𪗾 FCF7	<input type="checkbox"/>	𪗾 FD58	<input type="checkbox"/>

	E20	E21	E22	E23	E24	E25	E26	E27	E28	E29	E2A	E2B	E2C	E2D	E2E	E2F
0	穀 FD69	滂 FD79	落 FDAB							呌 FESC					龠 FECE	致 FEDE
1	倭 FD6A	滂 FD7A	薄 FDAC	游 FDBC		瀦 FDDC	燂 FDEC	鑄 FDFC	羣 FE4D	舩 FE5D	涸 FE6D	鏹 FE7D	隄 FEAF		會 FECE	璫 FEDE
2	孛 FD6B	滂 FD7B				瀦 FDDD			卒 FE4E		斐 FE6E	璩 FE7E			嶺 FED0	
3	孛 FD6C	炕 FD7C		潛 FDBE	澗 FDCE	瀦 FDDE						灑 FEA1				
4		玃 FD7D				縑 FDDF				焯 FE60	璩 FE70	璧 FEA2		玃 FEC2		
5	匏 FD6E	玃 FD7E			霽 FDD0					姦 FE61		鏹 FEA3				
6		沓 FDA1	琚 FDB1		澗 FDD1					璩 FE62	隅 FE72					
7	滂 FD70	婿 FDA2	澗 FDB2	斂 FDC2								鏹 FEA5	琬 FEB5	嶺 FEC5	睿 FED5	
8		沓 FDA3	滂 FDB3		灑 FDD3		煦 FDF3		猴 FE54	姁 FE64		璩 FEA6	璩 FEB6	皋 FEC6		礪 FEE6
9		啖 FDA4		塘 FDC4					猷 FE55	珩 FE65			疋 FEB7	皋 FEC7	瞬 FED7	
A	衫 FD73		靖 FDB5		灑 FDD5			爪 FE46	猷 FE56	珩 FE66		璩 FEA8				
B	玃 FD74	滂 FDA6		澗 FDC6	灑 FDD6		焯 FDF6		猷 FE57	璩 FE67					舒 FED9	
C	苻 FD75	苻 FDA7			灑 FDD7						爍 FE78				舒 FEDA	苻 FEFA
D				灑 FDC8	灑 FDD8	裊 FDE8	燈 FDF8	琫 FE49							物 FEDB	
E				漪 FDC9	灑 FDD9	燂 FDE9	璩 FDF9					隄 FEAC		蓋 FECC		
F		苻 FDAA	鏹 FDAB	灑 FDCA	灑 FDDA		璩 FDFA			璩 FE6B		宵 FEAD				釗 FEED

	E30	E31	E32	E33	E34	E35	E36	E37	E38	E39	E3A	E3B	E3C	E3D	E3E	E3F
0	渟 FEFE			睇 8E5F			嫩 8EB1				涇 8EF1					蓀 8FA4
1	伺 FEFF	滂 8E40		筠 8E60		縈 8EA2			鶻 8ED2	慙 8EE2		唅 8F43		煜 8F63	篔 8F73	
2					簾 8E71	縉 8EA3	轉 8EB3	羌 8EC3	韞 8ED3		壩 8EF3	婁 8F44	紗 8F54	葱 8F64	簾 8F74	夔 8FA6
3		稯 8E42								翻 8EE4		婁 8F45	娥 8F55		箒 8F75	夔 8FA7
4						蒟 8EA5	縵 8EB5	羨 8EC5		瞞 8EE5		崑 8F46			蔭 8F76	夔 8FA8
5		稽 8E44	翻 8E54	篠 8E64	獠 8E74		繇 8EB6	冲 8EC6			芑 8EF6	棧 8F47		沢 8F67		薄 8FA9
6	穉 FEF4	城 8E45	竝 8E55	苳 8E65				羣 8EC7	恕 8ED7	舉 8EE7	玳 8EF7					
7								釋 8EC8	駟 8ED8		棧 8EF8		儉 8F59		犂 8F79	墟 8FAB
8	禮 FEF6	鑄 8E47			脏 8E77		纜 8EB9	菹 8EC9	肇 8ED9	嬋 8EE9	婁 8EF9		夔 8F5A	芡 8F6A	藜 8F7A	嬋 8FAC
9								翰 8ECA	澗 8EDA		苳 8EFA	漭 8F4B		蓓 8F6B		
A			筭 8E59						勝 8EDB	璦 8EEB		蒧 8F4C		落 8F6C	蔭 8F7C	蝦 8FAE
B		穉 8E4A		纂 8E6A		綿 8EAC		熠 8ECC		璦 8EEC		芑 8F4D	儻 8F5D			
C	藪 FEFA	穎 8E4B	筵 8E5B	焮 8E6B		緞 8EAD				颯 8EED	勞 8EFD	茵 8F4E	稊 8F5E			
D	弘 FEFB			篠 8E6C					錯 8EDE		笙 8EFE	橙 8F4F	孛 8F5F		道 8FA1	鶻 8FB1
E						涘 8EAF				媿 8EEF		焯 8F50		苳 8F70	遠 8FA2	
F	靛 FEFD	窗 8E4E					罩 8EC0			艇 8EF0			箒 8F61			游 8FB3

	E40	E41	E42	E43	E44	E45	E46	E47	E48	E49	E4A	E4B	E4C	E4D	E4E	E4F
0					賚 8FF4	躡 9045	銖 9055				紆 90B7		蠱 90D7			
1					賜 8FF5	藁 9046	鋤 9056	遶 9066		鎚 90A8	怵 90B8		璫 90D8			
2				璦 8FE6			遯 9057	遯 9067		鑿 90A9	邳 90B9	聞 90C9				
3			誕 8FD7				洩 9058			鎌 90AA	垚 90BA	菌 90CA			焮 90FA	
4		裘 8FC8			嬪 8FF8			郟 9069	碧 9079		滄 90BB	倆 90CB			贛 90FB	
5			諱 8FD9				睇 905A			鑲 90AC	陷 90BC	叟 90CC			灑 90FC	
6	邨 8FBA		漪 8FDA	娥 8FEA				毳 906B	錠 907B	鑿 90AD		霏 90CD	彰 90DD	砒 90ED	乂 90FD	璩 914E
7			諫 8FDB	衍 8FEB			駘 905C		汞 907C	鑿 90AE		霏 90CE			灑 90FE	裔 914F
8			譚 8FDC		嘆 8FFC		誦 905D		鏡 907D			瓊 90CF			毓 9140	馥 9150
9	衍 8FBD				琰 8FFD	輓 904E	適 905E		簪 907E		稭 90C0	嬖 90D0	季 90E0	頤 90F0		駟 9151
A	淅 8FBE			頁 8FEE		辞 904F	寔 905F	暇 906F	咽 90A1			曠 90D1				
B	衍 8FBF	鏊 8FCF		頁 8FEF			慊 9060				蔭 90C2					
C			砮 8FE0	貫 8FF0	夏 9041		蓮 9061							韵 90F3		
D		觥 8FD1	礪 8FE1	嬖 8FF1	略 9042	虺 9052			鍵 90A4				斬 90E4	韵 90F4	颯 9145	
E	襖 8FC2	譜 8FD2		昭 8FE2	璫 9043	辰 9053	遊 9063	釐 9073	鑄 90A5			霰 90D5	斬 90E5	頤 90F5	蕤 9146	
F					楷 9044		繇 9064	崖 9074			錐 90C6	蕩 90D6			姆 9147	襖 9157

	E50	E51	E52	E53	E54	E55	E56	E57	E58	E59	E5A	E5B	E5C	E5D	E5E	E5F
0	姍 9158		鴻 9178					媿 91EA	姍 91FA	蘩 924B	滌 925B		徒 927B		蓋 92BD	琿 92CD
1	裘 9159		鷺 9179		駟 91BB					莢 924C	郝 925C	儻 926C			尅 92BE	懶 92CE
2	鬚 915A	鸞 916A					鋃 91DC	嫫 91EC	琦 91FC	榼 924D		價 926D	丛 927D		剋 92BF	
3					航 91BD	隴 91CD		槎 91ED	埼 91FD	鬻 924E					尅 92C0	唳 92D0
4		嫻 916C	鷺 917C	黏 91AE		琰 91CE		琿 91EE	垠 91FE	蓋 924F	朥 925F					
5	髯 915D					琯 91CF		嫫 91EF	塍 9240			祧 9270			鏗 92C2	瑋 92D2
6		丞 916E					釜 91E0	砣 91F0	壤 9241	孃 9251	魯 9261				剋 92C3	
7	鬢 915F			焯 91B1		瑄 91D1	燿 91E1	媿 91F1		穢 9252	奶 9262	仵 9272		榭 92B4		
8			龍 91A2			燈 91D2		嫫 91F2	槿 9243	焮 9253	嘆 9263	僂 9273	塚 92A5	滌 92B5		
9			鸞 91A3	栲 91B3		玦 91D3	琿 91E3	咏 91F3				僂 9274	涿 92A6	滌 92B6	劬 92C6	
A	頤 9162	鰈 9172	鸞 91A4	栲 91B4				媿 91F4		嫫 9255	鍬 9265	耙 9275				駟 92D7
B			鸞 91A5	梨 91B5	霁 91C5	鑿 91D5		媿 91F5	琿 9246			魯 9276		媿 92B8		瑾 92D8
C		鳩 9174	驪 91A6			媿 91D6		媿 91F6	馨 9247	皚 9257		仔 9277		溱 92B9	焯 92C9	灑 92D9
D	燄 9165	鴈 9175		呢 91B7			燿 91E7	媿 91F7	滌 9248	櫟 9258						
E	粥 9166	鰈 9176	鸞 91A8	鑿 91B8		鈿 91D8	燿 91E8	檢 91F8	磽 9249	灑 9259	嶮 9269	儻 9279			焯 92CB	咄 92DB
F	魁 9167	鴻 9177	慶 91A9			阡 91D9		媿 91F9	滌 924A	灑 925A	燿 926A	隕 927A		溱 92BC	咄 92CC	

	E60	E61	E62	E63	E64	E65	E66	E67	E68	E69	E6A	E6B	E6C	E6D	E6E	E6F
0	瀝 92DD	委 92ED			颯 935E		霽 937E		暝 93C0	煜 93D0	楞 93E0		肆 9441		坭 9461	
1		婁 92EE	糅 92FE		楓 935F	罌 936F		揠 93B1	畔 93C1		樵 93E1		鄣 9442	焯 9452	緹 9462	曷 9472
2	儻 92DF	嫫 92EF		獮 9350	颯 9360	仇 9370	犛 93A2		秦秦 93C2	莢 93D2	棧 93E2	嫫 93F2		焯 9453	璿 9463	曠 9473
3			鏗 9341	預 9351		仇 9371	揠 93A3		礪 93C3						罌 9464	曠 9474
4	叟 92E1		愷 9342	毒 9352		悉 9372	揠 93A4		鏗 93C4	驛 93D4	棧 93E4				瓏 9465	曠 9475
5					嬪 9363	蕙 9373	吊 93A5	榕 93B5	礪 93C5				聖 9446		鑿 9466	
6					嫫 9364		柁 93A6	漣 93B6	妊 93C6	覬 93D6	柁 93E6	欄 93F6			漣 9467	
7			培 9345	嬪 9355		委 9375	駮 93A7	晶 93B7	礎 93C7	崱 93D7			澀 9448	狃 9458		齋 9478
8				嬪 9356	妹 9366	奩 9376	攬 93A8	聖 93B8	礪 93C8				灑 9449	狃 9459	蒺 9469	曠 9479
9		窈 92F6	鏹 9347	嫫 9357		忤 9377		晶 93B9		睽 93D9	蒼 93E9	灑 93F9				
A		宓 92F7		嬪 9358			斂 93AA		旗 93CA	瞞 93DA		汇 93FA	灑 944B	璿 945B		鐳 947B
B		嫫 92F8	鏹 9349	嬪 9359	衡 9369			濟 93BB	嫫 93CB		龍 93EB			渙 945C		璿 947C
C	埤 92E9	焯 92F9		嬪 935A				濟 93BC	瞞 93CC	穉 93DC	燦 93EC					璿 947D
D		嫫 92FA	屨 934B	嬪 935B		揠 937B		韻 93BD	瞞 93CD	彪 93DD	燦 93ED	鏹 93FD		滄 945E	苻 946E	曠 947E
E					懺 936C	揠 937C	璿 93AE		瞞 93CE	燦 93DE		鎮 93FE		滄 945F	苻 946F	曠 94A1
F	鍼 92EC			鋪 935D	恚 936D	揠 937D	揠 93AF	機 93BF	昱 93CF	檣 93DF				璿 9460	苻 9470	璿 94A2

	E70	E71	E72	E73	E74	E75	E76	E77	E78	E79	E7A	E7B	E7C	E7D	E7E	E7F
0	蜀 94A3	惇 94B3		秊 94D3	惇 94E3		籊 9544	籊 9554	腺 9564	婚 9574			挑 95C6	終 95D6		琮 95F6
1	珩 94A4	櫟 94B4			燒 94E4	磁 94F4	莘 9545					黠 95B7	蜂 95C7	咏 95D7		琇 95F7
2	玕 94A5	櫟 94B5			醇 94E5	嫫 94F5	聿 9546			嫫 9576	裡 95A8					璩 95F8
3		吐 94B6		喧 94D6												濩 95F9
4			禰 94C7	瑄 94D7	佻 94E7		準 9548		臙 9568	嫫 9578	禰 95AA	焜 95BA	鬲 95CA		閔 95EA	
5			帶 94C8	值 94D8			榨 9549	柀 9559			轡 95AB			醜 95DB		
6	璠 94A9	珉 94B9	倚 94C9	涓 94D9				拑 955A	旋 956A	蜨 957A	鏗 95AC				珩 95EC	璠 95FC
7	嫫 94AA	璠 94BA		媼 94DA	綰 94EA		羿 954B	珉 955B		澆 957B	鏗 95AD		綰 95CD		珩 95ED	
8		璠 94BB		吟 94DB			弛 954C	諭 955C			璠 95AE	鳩 95BE		鍔 95DE	璠 95EE	璠 95FE
9	瞭 94AC	碯 94BC			箬 94EC		皓 954D		棘 956D	螻 957D	鋤 95AF			瞭 95DF	燭 95EF	
A	瞭 94AD	璠 94BD		吒 94DD				睽 955E			玕 95B0		廻 95D0	鍔 95E0	璠 95F0	霄 9641
B		繳 94BE	湛 94CE	媼 94DE		璠 94FE			裴 956F				廻 95D1		諭 95F1	零 9642
C	睽 94AF			任 94DF	篙 94EF	縉 9540	劔 9550	藹 9560			設 95B2	賄 95C2		鐮 95E2		馱 9643
D		磳 94C0		吐 94E0	筮 94F0	譚 9541	笱 9551	某 9561	齧 9571		詭 95B3			鑿 95E3	陷 95F3	
E			穉 94D1		粳 94F1		簞 9552	莒 9562			嶮 95B4		媼 95D4		隄 95F4	
F			炳 94D2		粘 94F2	糲 9543			穉 9573						隄 95F5	鍊 9646

	E80	E81	E82	E83	E84	E85	E86	E87	E88	E89	E8A	E8B	E8C	E8D	E8E	E8F
0	鑛 9647					鴉 96B9	蔭 96C9		吝 96E9		嫫 974A	鏢 975A	絜 976A	鑣 977A	斲 97AC	
1	鐸 9648	頽 9658	譚 9668	驪 9678	颯 96AA	鴻 96BA	薈 96CA	倌 96DA		菁 96FA	嚙 974B		儻 976B	礮 977B	斲 97AD	鏢 97BD
2	癩 9649		燂 9669	駢 9679	態 96AB		淳 96CB			煌 96FB			絜 976C	銜 977C	斲 97AE	嫫 97BE
3		颯 965A				鴉 96BC					妹 974D	璦 975D	望 976D	銜 977D		
4			舐 966B							煥 96FD	墟 974E				嫫 97B0	沛 97C0
5		苦 965C		塗 967C		鷄 96BE	基 96CE			換 96FE	煩 974F	鏗 975F	珮 976F	玟 97A1	鏗 97B1	歷 97C1
6	錄 964D	鐸 965D				鴉 96BF	樛 96CF	伏 96DF			搯 9750	熒 9760		呢 97A2	璦 97B2	馥 97C2
7		瑄 965E	鏢 966E	琮 967E		鴉 96C0	綫 96D0		炆 96F0		灑 9751	璦 9761	琊 9771			懣 97C3
8	炆 964F	鏢 965F	稜 966F	壘 96A1		鴉 96C1		礪 96E1				璦 9762		摩 97A4	嫫 97B4	
9							楫 96D2			紕 9743	焱 9753			吠 97A5	媧 97B5	藻 97C5
A		鏢 9661		惘 96A3			楫 96D3			燻 9744	腓 9754			喟 97A6	媧 97B6	滙 97C6
B		璦 9662		溱 96A4	鯨 96B4	蔞 96C4	銜 96D4			嬾 9745			蠡 9775			埔 97C7
C	曼 9653					綺 96C5	璞 96D5			駢 9746	縶 9756	球 9766			媧 97B8	
D		銳 9664	駟 9674	澗 96A6	鸕 96B6	菅 96C6	潘 96D6	媧 96E6		鏘 9747	緝 9757	琨 9767	鑫 9777	媧 97A9	透 97B9	綃 97C9
E	鐸 9655				鴉 96B7			晤 96E7	燁 96F7		瑱 9758	璦 9768	璦 9778		姪 97BA	躬 97CA
F	瑪 9656		駟 9676	怡 96A8		蒸 96C8		珞 96E8	炆 96F8		璦 9759	媧 9769		姪 97AB		

	E90	E91	E92	E93	E94	E95	E96	E97	E98	E99	E9A	E9B	E9C	E9D	E9E	E9F
0	霄 97CC	靚 97DC	戴 97EC			焯 985D	焯 986D					昧 98DF		襪 9940		
1	萼 97CD	瑚 97DD	垺 97ED	萵 97FD	嫫 984E		埤 986E		鎰 98B0	玕 98C0	𩇛 98D0					
2		輻 97DE	汲 97EE	葯 97FE		溼 985F			馱 98B1		𩇛 98D1					
3	贖 97CF			蓉 9840		裡 9860		鎗 98A2								
4				蒟 9841	嫻 9851	爇 9861	勳 9871	曦 98A3		琬 98C3						
5		鎔 97E1	堦 97F1	葯 9842	焯 9852	焯 9862	炆 9872	金 98A4				眈 98E4	斫 98F4		籥 9955	
6	浓 97D2		梁 97F2	蕙 9843	媼 9853					琇 98C5				稽 9946	𩇛 9956	
7	漾 97D3	鑄 97E3	登 97F3			焯 9864	勇 9874	甸 98A6	謹 98B6		疔 98D6	映 98E6				翻 9967
8	溼 97D4	莖 97E4	擘 97F4	蕙 9845	媼 9855	鋸 9865	琄 9875	灤 98A7						窳 9948		
9			鎔 97F5		姪 9856			睽 98A8				眈 98E8			𩇛 9959	
A			櫛 97F6	媼 9847		蓓 9867		巖 98A9	禧 98B9		癩 98D9	咲 98E9				
B	瀟 97D7	媼 97E7	杺 97F7					𩇛 98AA					磁 98FA	竈 994B	糗 995B	
C	佩 97D8	墩 97E8	晴 97F8	蓓 9849		熾 9869	𩇛 9879			琬 98CB	癩 98DB	晰 98EB				
D				蕙 984A	焯 985A	熾 986A		霽 98AC	玕 98BC	璿 98CC		睽 98EC				
E	媼 97DA	壘 97EA	櫛 97FA	媼 984B		熾 986B	璿 987B		調 98BD	璿 98CD	癩 98DD			醇 994E		焯 996E
F	洩 97DB	鑿 97EB	蒞 97FB				媼 987C			歷 98CE			袂 98FE		𩇛 995F	

	EA0	EA1	EA2	EA3	EA4	EA5	EA6	EA7	EA8	EA9	EAA	EAB	EAC	EAD	EAE	EAF
0										颯 9A63			傲 9AB5	贗 9AC5	唳 9AD5	嗚 9AE5
1			莛 99B3	藪 99C3									儻 9AB6	吶 9AC6	啞 9AD6	噤 9AE6
2									閱 9A55						嘔 9AD7	噦 9AE7
3	眈 9973	睞 99A5			眈 99D5		遠 99F5							呌 9AC8	喙 9AD8	
4														吟 9AC9		嗞 9AE9
5		睞 99A7		藜 99C7				璽 9A48	隄 9A58				兔兔 9ABA			噤 9AEA
6							鈇 99F8	鏤 9A49			鮒 9A79			吻 9ACB		噤 9AEB
7						眺 99E9			霽 9A5A					吻 9ACC	噤 9ADC	塚 9AEC
8											審 9A7B		峒 9ABD	脆 9ACD	嗞 9ADD	噤 9AED
9									霽 9A5C		允 9A7C		浚 9ABE	哂 9ACE	噤 9ADE	噤 9AEE
A	豚 997A		蓄 99BC										灑 9ABF	烤 9ACF	隆 9ADF	噤 9AEF
B	睞 997B	艷 99AD								稔 9A6E			冫 9AC0		噤 9AE0	噤 9AF0
C				噤 99CE	趁 99DE								夙 9AC1	唾 9AD1	噤 9AE1	
D				衛 99CF				鏹 9A50	顛 9A60	驪 9A70						
E														叻 9AD3	噤 9AE3	挂 9AF3
F	頤 99A1				昨 99E1							劣 9AB4	廬 9AC4	唔 9AD4		墜 9AF4

	EB0	EB1	EB2	EB3	EB4	EB5	EB6	EB7	EB8	EB9	EBA	EBB	EBC	EBD	EBE	EBF
0	埖 9AF5	□	戚 9B56	掠 9B66	□	亭 9BA8	槲 9BB8	琰 9BC8	溶 9BD8	蕘 9BE8	𪔐 9BF8	穉 9C49	□	环 9C69	𪔑 9C79	□
1	□	歲 9B47	咏 9B57	擗 9B67	琦 9B77	郑 9BA9	淳 9BB9	勘 9BC9	珮 9BD9	□	□	驕 9C4A	□	□	蓀 9C7A	蛄 9CAC
2	𪔒 9AF7	嶠 9B48	□	揄 9B68	□	頤 9BAA	燎 9BBA	□	□	剗 9BEA	繆 9BFA	睇 9C4B	葳 9C5B	□	□	琣 9CAD
3	𪔓 9AF8	□	搥 9B59	攜 9B69	棗 9B79	瀟 9BAB	變 9BBB	齧 9BCB	砌 9BDB	杞 9BEB	皁 9BFB	晒 9C4C	轡 9C5C	灑 9C6C	□	□
4	婉 9AF9	□	□	敎 9B6A	橙 9B7A	鉞 9BAC	□	啞 9BCC	砧 9BDC	□	□	愆 9C4D	□	□	耘 9C7D	□
5	嫁 9AFA	𪔔 9B4B	拒 9B5B	𪔕 9B6B	□	熙 9BAD	掉 9BBD	□	芷 9BDD	𪔖 9BED	玃 9BFD	□	脍 9C5E	舩 9C6E	□	蟠 9CB0
6	□	□	□	𪔗 9B6C	衛 9B7C	燿 9BAE	舉 9BBE	瘠 9BCE	□	賄 9BEE	猜 9BFE	粽 9C4F	膳 9C5F	瑚 9C6F	嫩 9CA1	嗣 9CB1
7	□	烤 9B4D	搥 9B5D	𪔘 9B6D	□	潔 9BAF	狻 9BBF	睨 9BCF	傷 9BDF	鈺 9BEF	□	□	翊 9C60	獬 9C70	衡 9CA2	□
8	嫿 9AFD	脣 9B4E	□	𪔙 9B6E	□	爍 9BB0	遑 9BC0	剗 9BD0	𪔚 9BE0	璋 9BF0	玳 9C41	□	滕 9C61	𪔛 9C71	蕙 9CA3	□
9	𪔛 9AFE	𪔜 9B4F	□	枕 9B6F	□	煠 9BB1	𪔝 9BC1	□	祉 9BE1	筭 9BF1	□	晋 9C52	□	□	𪔞 9CA4	懂 9CB4
A	𪔟 9B40	粥 9B50	揲 9B60	□	𪔡 9BA2	瑤 9BB2	寓 9BC2	屨 9BD2	璋 9BE2	箒 9BF2	𪔣 9C43	□	𪔥 9C63	𪔦 9C73	𪔧 9CA5	廷 9CB5
B	𪔩 9B41	𪔪 9B51	□	□	祐 9BA3	涇 9BB3	絲 9BC3	□	𪔫 9BE3	咖 9BF3	𪔬 9C44	□	□	𪔭 9C74	𪔮 9CA6	𪔯 9CB6
C	𪔰 9B42	𪔱 9B52	𪔲 9B62	□	紘 9BA4	□	□	□	𪔴 9BE4	□	□	𪔵 9C55	𪔶 9C65	□	𪔷 9CA7	□
D	𪔹 9B43	𪔺 9B53	揆 9B63	詭 9B73	漆 9BA5	𪔻 9BB5	鎰 9BC5	□	𪔽 9BE5	□	瓊 9C46	𪔿 9C56	𪔿 9C66	𪔿 9C76	□	𪔿 9CB8
E	𪔿 9B44	□	𪔿 9B64	𪔿 9B74	𪔿 9BA6	□	□	𪔿 9BD6	𪔿 9BE6	□	𪔿 9C47	□	𪔿 9C67	□	𪔿 9CA9	𪔿 9CB9
F	𪔿 9B45	𪔿 9B55	𪔿 9B65	𪔿 9B75	𪔿 9BA7	𪔿 9BB7	𪔿 9BC7	𪔿 9BD7	𪔿 9BE7	𪔿 9BF7	𪔿 9C48	𪔿 9C58	□	𪔿 9C78	𪔿 9CAA	𪔿 9CBA

	EC0	EC1	EC2	EC3	EC4	EC5	EC6	EC7	EC8	EC9	ECA	ECB	ECC	ECD	ECE	ECF	
0	婭 9CBB	塋 9CCB	踣 9CDB		躡 9CFB		霏 9D5C	酖 9D6C	呶 9D7C		嘔 9DBE	鮪 9DCE		嚙 9DEE	捺 9DFE	逗 9E4F	
1				鑛 9CEC	蹕 9CFC		燠 9D5D	髻 9D6D		媯 9DAF					喙 9E40		
2			麟 9CDD	跹 9CED	簪 9CFD	銃 9D4E	黷 9D5E	魷 9D6E		跖 9DB0							攪 9E51
3	葷 9CBE	訝 9CCE			躡 9CFE	睇 9D4F	璽 9D5F	魷 9D6F		鎬 9DB1	洳 9DC1						
4		霽 9CCF	較 9CDF		躡 9D40	錡 9D50			穢 9DA2	鎔 9DB2	畚 9DC2	糝 9DD2		輓 9DF2		剋 9E53	
5	賦 9CC0			釧 9CF0	躡 9D41	胝 9D51		鯁 9D71		深 9DB3				坳 9DF3	嚙 9E44	咭 9E54	
6	馱 9CC1	梟 9CD1	荷 9CE1		靴 9D42	鍋 9D52		鰻 9D72	璿 9DA4	胤 9DB4	涅 9DD4						
7		醴 9CD2		琿 9CF2	輓 9D43	鏗 9D53	頤 9D63	鮓 9D73	蒜 9DA5	熨 9DB5	娥 9DC5						
8	襪 9CC3	翎 9CD3			輓 9D44	壘 9D54	鋼 9D64			袜 9DB6	媚 9DC6						
9	親 9CC4	諱 9CD4			輓 9D45		飭 9D65	慶 9D75		洵 9DB7		嘖 9DD7					
A		訴 9CD5	躡 9CE5		品 9D46	斲 9D56	颯 9D66			袒 9DB8		吭 9DD8					
B	磳 9CC6	證 9CD6	跲 9CE6	瑩 9CF6	迫 9D47		馥 9D67	赴 9D77		窄 9DB9	箴 9DC9	燻 9DD9		哧 9DF9			
C	畚 9CC7	眈 9CD7	鬆 9CE7	淇 9CF7	邨 9D48	雒 9D58	駮 9D68	鸕 9D78	刮 9DAA					叻 9DFA		曝 9E5B	
D	爍 9CC8	滄 9CD8	塹 9CE8	櫟 9CF8	醜 9D49	霽 9D59	豎 9D69		鎬 9DAB	粧 9DBB	瞻 9DCB						
E	橙 9CC9		翳 9CE9				驥 9D6A	齋 9D7A	覷 9DAC	罇 9DBC	焯 9DCC			眈 9DFC			
F	躡 9CCA		躡 9CEA	踣 9CEA	叢 9D4B	霽 9D5B	驪 9D6B	齧 9D7B	嬾 9DAD		魴 9DCD		咯 9DED	呷 9DFD			

	ED0	ED1	ED2	ED3	ED4	ED5	ED6	ED7	ED8	ED9	EDA	EDB	EDC	EDD	EDE	EDF
0		焯 9E6F														
1		蝮 9E70			鏖 9EC2	深 9ED2		航 9EF2	婞 9F43	炭 9F53			斂 9FA5	蓰 9FB5	哿 9FC5	
2			擗 9EA3		鷗 9EC3	蛭 9ED3	啞 9EE3	熿 9EF3								
3		囧 9E72	醜 9EA4	呷 9EB4		脬 9ED4										嘍 9FD7
4	嘍 9E63		狷 9EA5		撻 9EC5	樾 9ED5	趨 9EE5		頰 9F46							
5	葦 9E64	深 9E74	鮫 9EA6		彙 9EC6			垚 9EF6	囧 9F47							嗒 9FD9
6		嚙 9E75	嚙 9EA7				磻 9EE7		贛 9F48		玨 9F68		娟 9FAA			
7	隴 9E66	呷 9E76	啞 9EA8	姁 9EB8	鮭 9EC8	澗 9ED8		琬 9EF8						儻 9FBB		
8		啜 9E77		拈 9EB9	鸚 9EC9	沼 9ED9		鮓 9EF9	啗 9F4A							
9			蠶 9EAA			擗 9EDA			蒹 9F4B							
A	𪛗 9E69	𪛘 9E79	𪛙 9EAB	𪛚 9EBB	𪛛 9ECB			靜 9EFB	璿 9F4C					籛 9FBE		
B		𪛜 9E7A		𪛝 9EBC	𪛞 9ECC		𪛟 9EEC	𪛠 9EFC	𪛡 9F4D					𪛢 9FBF		
C	𪛣 9E6B	𪛤 9E7B	𪛥 9EAD		𪛦 9ECD	𪛧 9EDD										
D	𪛨 9E6C	𪛩 9E7C	𪛪 9EAE	𪛫 9EBE	𪛬 9ECE	𪛭 9EDE	𪛮 9EEE							𪛯 9FC1	𪛰 9FD1	
E	𪛱 9E6D	𪛲 9E7D			𪛳 9ECF	𪛴 9EDF			𪛵 9F50		𪛶 9F70					
F	𪛷 9E6E	𪛸 9E7E			𪛹 9ED0	𪛺 9EE0	𪛻 9EF0							𪛼 9FB3		

	EE0	EE1	EE2	EE3	EE4	EE5	EE6	EE7	EE8	EE9	EEA	EEB	EEC	EED	EEE	EEF
0	<input type="checkbox"/>	<input type="checkbox"/>	𪛗 A045	媯 A055	<input type="checkbox"/>	<input type="checkbox"/>	岷 A0A7	<input type="checkbox"/>	<input type="checkbox"/>	<input type="checkbox"/>	<input type="checkbox"/>	臄 A0F7				
1	<input type="checkbox"/>	𪛘 9FF5	<input type="checkbox"/>	𪛙 A056	<input type="checkbox"/>	<input type="checkbox"/>	<input type="checkbox"/>	<input type="checkbox"/>	<input type="checkbox"/>	漚 A0D8	𪛚 A0E8	𪛛 A0F8				
2	<input type="checkbox"/>	<input type="checkbox"/>	𪛜 A047	<input type="checkbox"/>	<input type="checkbox"/>	<input type="checkbox"/>	<input type="checkbox"/>	<input type="checkbox"/>	<input type="checkbox"/>	<input type="checkbox"/>	𪛞 A0E9	𪛟 A0F9				
3	<input type="checkbox"/>	<input type="checkbox"/>	<input type="checkbox"/>	<input type="checkbox"/>	𪛠 A068	𪛡 A078	<input type="checkbox"/>	<input type="checkbox"/>	<input type="checkbox"/>	𪛣 A0DA	𪛤 A0EA	<input type="checkbox"/>				
4	<input type="checkbox"/>	<input type="checkbox"/>	<input type="checkbox"/>	𪛥 A059	<input type="checkbox"/>	<input type="checkbox"/>	𪛧 A0AB	<input type="checkbox"/>	<input type="checkbox"/>	<input type="checkbox"/>	𪛩 A0EB	𪛪 A0FB				
5	<input type="checkbox"/>	𪛬 9FF9	<input type="checkbox"/>	<input type="checkbox"/>	𪛮 A06A	<input type="checkbox"/>	𪛯 A0AC	<input type="checkbox"/>	<input type="checkbox"/>	<input type="checkbox"/>	𪛱 A0EC	<input type="checkbox"/>				
6	<input type="checkbox"/>	<input type="checkbox"/>	<input type="checkbox"/>	<input type="checkbox"/>	<input type="checkbox"/>	𪛳 A07B	<input type="checkbox"/>	𪛴 A0BD	<input type="checkbox"/>	<input type="checkbox"/>	𪛶 A0ED	<input type="checkbox"/>				
7	<input type="checkbox"/>	<input type="checkbox"/>	<input type="checkbox"/>	<input type="checkbox"/>	<input type="checkbox"/>	<input type="checkbox"/>	<input type="checkbox"/>	<input type="checkbox"/>	<input type="checkbox"/>	𪛹 A0DE	𪛺 A0EE	𪛻 A0FE				
8	𪛼 9FEC	<input type="checkbox"/>	<input type="checkbox"/>	<input type="checkbox"/>	𪛾 A06D	<input type="checkbox"/>	<input type="checkbox"/>	<input type="checkbox"/>	<input type="checkbox"/>	<input type="checkbox"/>	𪛿 A0EF					
9	<input type="checkbox"/>	<input type="checkbox"/>	<input type="checkbox"/>	<input type="checkbox"/>	<input type="checkbox"/>	𪛿 A07E	<input type="checkbox"/>	<input type="checkbox"/>	𪛿 A0D0	<input type="checkbox"/>	𪛿 A0F0					
A	<input type="checkbox"/>	<input type="checkbox"/>	𪛿 A04F	<input type="checkbox"/>	𪛿 A06F	<input type="checkbox"/>	𪛿 A0B1	<input type="checkbox"/>	<input type="checkbox"/>	<input type="checkbox"/>	𪛿 A0F1					
B	<input type="checkbox"/>	𪛿 A040	<input type="checkbox"/>	<input type="checkbox"/>	<input type="checkbox"/>	𪛿 A0A2	<input type="checkbox"/>	<input type="checkbox"/>	<input type="checkbox"/>	<input type="checkbox"/>	<input type="checkbox"/>					
C	<input type="checkbox"/>	<input type="checkbox"/>	<input type="checkbox"/>	<input type="checkbox"/>	<input type="checkbox"/>	<input type="checkbox"/>	<input type="checkbox"/>	𪛿 A0C3	<input type="checkbox"/>	𪛿 A0E3	𪛿 A0F3					
D	<input type="checkbox"/>	<input type="checkbox"/>	<input type="checkbox"/>	<input type="checkbox"/>	<input type="checkbox"/>	𪛿 A0A4	<input type="checkbox"/>	<input type="checkbox"/>	<input type="checkbox"/>	<input type="checkbox"/>	𪛿 A0F4					
E	<input type="checkbox"/>	<input type="checkbox"/>	𪛿 A053	<input type="checkbox"/>	<input type="checkbox"/>	<input type="checkbox"/>	<input type="checkbox"/>	𪛿 A0C5	<input type="checkbox"/>	<input type="checkbox"/>	𪛿 A0F5					
F	<input type="checkbox"/>	<input type="checkbox"/>	<input type="checkbox"/>	<input type="checkbox"/>	<input type="checkbox"/>	<input type="checkbox"/>	<input type="checkbox"/>	<input type="checkbox"/>	<input type="checkbox"/>	𪛿 A0E6	𪛿 A0F6					

	EF0	EF1	EF2	EF3	EF4	EF5	EF6	EF7	EF8	EF9	EFA	EFB	EFC	EFD	EFE	EFF
0																
1																
2																
3																
4																
5																
6																
7																
8																
9																
A																
B																
C																
D																
E																
F																

	F00	F01	F02	F03	F04	F05	F06	F07	F08	F09	F0A	F0B	F0C	F0D	F0E	F0F
0																
1																
2																
3																
4																
5																
6																
7																
8																
9																
A																
B																
C																
D																
E																
F																

	F10	F11	F12	F13	F14	F15	F16	F17	F18	F19	F1A	F1B	F1C	F1D	F1E	F1F
0																
1																
2																
3																
4																
5																
6																
7																
8																
9																
A																
B																
C																
D																
E																
F																







	F20	F21	F22	F23	F24	F25	F26	F27	F28	F29	F2A	F2B	F2C	F2D	F2E	F2F
0																
1																
2																
3																
4																
5																
6																
7																
8																
9																
A																
B																
C																
D																
E																
F																

	F30	F31	F32	F33	F34	F35	F36	F37	F38	F39	F3A	F3B	F3C	F3D	F3E	F3F
0		𠃉 884D	<input type="checkbox"/>	<input type="checkbox"/>	<input type="checkbox"/>						𠃊 8940	<input type="checkbox"/>	<input type="checkbox"/>	<input type="checkbox"/>	<input type="checkbox"/>	𠃋 89B2
1		𠃌 884E	<input type="checkbox"/>	<input type="checkbox"/>	<input type="checkbox"/>						𠃍 8941	<input type="checkbox"/>	<input type="checkbox"/>	<input type="checkbox"/>	<input type="checkbox"/>	
2		𠃎 884F	<input type="checkbox"/>	<input type="checkbox"/>	<input type="checkbox"/>							<input type="checkbox"/>	<input type="checkbox"/>	<input type="checkbox"/>	<input type="checkbox"/>	
3	𠃏 8840	𠃑 8850	<input type="checkbox"/>	<input type="checkbox"/>	<input type="checkbox"/>						<input type="checkbox"/>	<input type="checkbox"/>	<input type="checkbox"/>	<input type="checkbox"/>	<input type="checkbox"/>	<input type="checkbox"/>
4	𠃒 8841	𠃔 8851	<input type="checkbox"/>	<input type="checkbox"/>	ē 88A3							<input type="checkbox"/>	<input type="checkbox"/>	<input type="checkbox"/>	<input type="checkbox"/>	<input type="checkbox"/>
5	𠃕 8842	𠃗 8852	ē 8862	<input type="checkbox"/>	<input type="checkbox"/>							<input type="checkbox"/>	<input type="checkbox"/>	<input type="checkbox"/>		𠃙 89B7
6	𠃘 8843	𠃚 8853	<input type="checkbox"/>	<input type="checkbox"/>	ě 88A5						<input type="checkbox"/>	<input type="checkbox"/>	<input type="checkbox"/>	<input type="checkbox"/>		<input type="checkbox"/>
7	𠃛 8844	𠃝 8854	ē 8864	<input type="checkbox"/>	<input type="checkbox"/>						<input type="checkbox"/>	<input type="checkbox"/>	<input type="checkbox"/>	<input type="checkbox"/>		<input type="checkbox"/>
8	𠃞 8845	𠃠 8855	<input type="checkbox"/>	<input type="checkbox"/>	<input type="checkbox"/>						<input type="checkbox"/>	<input type="checkbox"/>	<input type="checkbox"/>	<input type="checkbox"/>		𠃡 89BA
9	𠃣 8846	<input type="checkbox"/>	<input type="checkbox"/>	<input type="checkbox"/>	<input type="checkbox"/>						<input type="checkbox"/>	<input type="checkbox"/>	<input type="checkbox"/>	<input type="checkbox"/>	<input type="checkbox"/>	𠃣 89BB
A	𠃧 8847	<input type="checkbox"/>	<input type="checkbox"/>	<input type="checkbox"/>	≡ 88A9							<input type="checkbox"/>	<input type="checkbox"/>	<input type="checkbox"/>	<input type="checkbox"/>	𠃧 89BC
B	𠃩 8848	<input type="checkbox"/>	<input type="checkbox"/>	<input type="checkbox"/>	⊖ 88AA							<input type="checkbox"/>	<input type="checkbox"/>	<input type="checkbox"/>	<input type="checkbox"/>	<input type="checkbox"/>
C	𠃭 8849	<input type="checkbox"/>	<input type="checkbox"/>	<input type="checkbox"/>							𠃭 894C	<input type="checkbox"/>	<input type="checkbox"/>	<input type="checkbox"/>	<input type="checkbox"/>	𠃭 89BE
D	𠃯 884A	<input type="checkbox"/>	<input type="checkbox"/>	<input type="checkbox"/>							<input type="checkbox"/>	<input type="checkbox"/>	<input type="checkbox"/>	<input type="checkbox"/>		𠃯 89BF
E	𠃱 884B	<input type="checkbox"/>	<input type="checkbox"/>	<input type="checkbox"/>							<input type="checkbox"/>	<input type="checkbox"/>	<input type="checkbox"/>	<input type="checkbox"/>	<input type="checkbox"/>	
F	𠃳 884C	<input type="checkbox"/>	<input type="checkbox"/>	<input type="checkbox"/>							<input type="checkbox"/>	<input type="checkbox"/>	<input type="checkbox"/>	<input type="checkbox"/>	<input type="checkbox"/>	<input type="checkbox"/>

	F40	F41	F42	F43	F44	F45	F46	F47	F48	F49	F4A	F4B	F4C	F4D	F4E	F4F
0					𠵼 8A43	躑 8A53			𠵼 8AA5	𠵼 8AB5		𠵼 8AD5	𠵼 8AE5		揜 8B46	
1					𠵼 8A44	𠵼 8A54	𠵼 8A64		𠵼 8AA6	𠵼 8AB6			𠵼 8AE6	𠵼 8AF6	揜 8B47	
2					𠵼 8A45	𠵼 8A55	𠵼 8A65				𠵼 8AC7	𠵼 8AD7		𠵼 8AF7	𠵼 8B48	𠵼 8B58
3	𠵼 89C5	𠵼 89D5					𠵼 8A66	𠵼 8A76	𠵼 8AA8	𠵼 8AB8		𠵼 8AD8	𠵼 8AE8	𠵼 8AF8	𠵼 8B49	𠵼 8B59
4			𠵼 89E6		𠵼 8A47	𠵼 8A57	𠵼 8A67	𠵼 8A77	𠵼 8AA9	𠵼 8AB9	𠵼 8AC9	𠵼 8AD9	𠵼 8AE9	𠵼 8AF9	𠵼 8B4A	
5		𠵼 89D7			𠵼 8A48	𠵼 8A58	𠵼 8A68		𠵼 8AAA		𠵼 8ACA	𠵼 8ADA	𠵼 8AEA	𠵼 8AFA	𠵼 8B4B	
6			𠵼 89E8		𠵼 8A49	𠵼 8A59	𠵼 8A69			𠵼 8ABB	𠵼 8ACB		𠵼 8AEB	𠵼 8AFB	𠵼 8B4C	
7				𠵼 89F9		𠵼 8A5A		𠵼 8A7A	𠵼 8AAC	𠵼 8ABC	𠵼 8ACC	𠵼 8ADC	𠵼 8AEC	𠵼 8AFC	𠵼 8B4D	
8	𠵼 89CA	𠵼 89DA	𠵼 89EA		𠵼 8A4B		𠵼 8A6B	𠵼 8A7B	𠵼 8AAD	𠵼 8ABD			𠵼 8AED		𠵼 8B4E	𠵼 8B5E
9	𠵼 89CB	𠵼 89DB		𠵼 89FB	𠵼 8A4C		𠵼 8A6C	𠵼 8A7C	𠵼 8AAE		𠵼 8ACE		𠵼 8AEE	𠵼 8AFE	𠵼 8B4F	
A	𠵼 89CC	𠵼 89DC		𠵼 89FC	𠵼 8A4D	𠵼 8A5D	𠵼 8A6D	𠵼 8A7D			𠵼 8ACF	𠵼 8ADF	𠵼 8AEF	𠵼 8B40		𠵼 8B60
B	𠵼 89CD		𠵼 89ED		𠵼 8A4E	𠵼 8A5E	𠵼 8A6E	𠵼 8A7E	𠵼 8AB0	𠵼 8AC0	𠵼 8AD0	𠵼 8AE0	𠵼 8AF0	𠵼 8B41		
C			𠵼 89EE	𠵼 89FE		𠵼 8A5F	𠵼 8A6F	𠵼 8AA1			𠵼 8AD1	𠵼 8AE1	𠵼 8AF1	𠵼 8B42		𠵼 8B62
D			𠵼 89EF	𠵼 8A40	𠵼 8A50	𠵼 8A60	𠵼 8A70	𠵼 8AA2	𠵼 8AB2	𠵼 8AC2	𠵼 8AD2	𠵼 8AE2	𠵼 8AF2	𠵼 8B43		
E					𠵼 8A51	𠵼 8A61	𠵼 8A71	𠵼 8AA3	𠵼 8AB3	𠵼 8AC3	𠵼 8AD3	𠵼 8AE3	𠵼 8AF3	𠵼 8B44		𠵼 8B64
F					𠵼 8A52	𠵼 8A62	𠵼 8A72		𠵼 8AB4		𠵼 8AD4	𠵼 8AE4	𠵼 8AF4	𠵼 8B45	𠵼 8B55	𠵼 8B65

	F50	F51	F52	F53	F54	F55	F56	F57	F58	F59	F5A	F5B	F5C	F5D	F5E	F5F
0	噉 8B66	癩 8B76	嘍 8BA8	儀 8BB8	巳 8BC8											
1	噤 8B67	擻 8B77	睛 8BA9													
2	噉 8B68		麇 8BAA					𠂇 8BFA								
3	痢 8B69	噤 8B79	璫 8BAB	竽 8BBB		𠂇 8BDB										
4	噤 8B6A	噤 8B7A	癩 8BAC	𠂇 8BBC	小 8BCC	𠂇 8BDC										
5	噉 8B6B	噉 8B7B	灑 8BAD				𠂇 8BED									
6		噉 8B7C	聽 8BAE	噉 8BBE		𠂇 8BDE										
7	噉 8B6D															
8	噉 8B6E	噉 8B7E														
9	噉 8B6F	桶 8BA1	噉 8BB1			𠂇 8BE1										
A	噉 8B70	軌 8BA2	噉 8BB2	九 8BC2		𠂇 8BE2										
B	噉 8B71	噉 8BA3		𠂇 8BC3			𠂇 8BF3									
C	噉 8B72	噉 8BA4														
D	躑 8B73	脏 8BA5	踏 8BB5	𠂇 8BC5												
E	琛 8B74	媼 8BA6	缺 8BB6		王 8BD6	角 8BE6										
F	噉 8B75	噉 8BA7														

	F60	F61	F62	F63	F64	F65	F66	F67	F68	F69	F6A	F6B	F6C	F6D	F6E	F6F
0					<input type="checkbox"/>	<input type="checkbox"/>	<input type="checkbox"/>	<input type="checkbox"/>	<input type="checkbox"/>	<input type="checkbox"/>	<input type="checkbox"/>	嗷 8DFE	<input type="checkbox"/>	<input type="checkbox"/>	<input type="checkbox"/>	<input type="checkbox"/>
1					忪 8D6D	惇 8D7D	<input type="checkbox"/>	<input type="checkbox"/>	<input type="checkbox"/>	<input type="checkbox"/>	漾 8DEF	<input type="checkbox"/>	<input type="checkbox"/>	<input type="checkbox"/>	<input type="checkbox"/>	<input type="checkbox"/>
2					俯 8D6E	<input type="checkbox"/>	晡 8DB0	<input type="checkbox"/>	<input type="checkbox"/>	<input type="checkbox"/>	潔 8DF0	<input type="checkbox"/>	<input type="checkbox"/>	<input type="checkbox"/>	<input type="checkbox"/>	<input type="checkbox"/>
3					俺 8D6F	惇 8DA1	<input type="checkbox"/>	<input type="checkbox"/>	<input type="checkbox"/>	<input type="checkbox"/>	<input type="checkbox"/>	<input type="checkbox"/>	<input type="checkbox"/>	<input type="checkbox"/>	<input type="checkbox"/>	<input type="checkbox"/>
4				<input type="checkbox"/>	惧 8D70	<input type="checkbox"/>	曦 8DB2	<input type="checkbox"/>	<input type="checkbox"/>	鉏 8DE2	<input type="checkbox"/>	<input type="checkbox"/>	<input type="checkbox"/>	<input type="checkbox"/>	<input type="checkbox"/>	<input type="checkbox"/>
5				<input type="checkbox"/>	<input type="checkbox"/>	<input type="checkbox"/>	<input type="checkbox"/>	梲 8DC3	<input type="checkbox"/>	<input type="checkbox"/>	灑 8DF3	<input type="checkbox"/>	<input type="checkbox"/>	<input type="checkbox"/>	<input type="checkbox"/>	<input type="checkbox"/>
6				<input type="checkbox"/>	<input type="checkbox"/>	<input type="checkbox"/>	杓 8DB4	<input type="checkbox"/>	<input type="checkbox"/>	<input type="checkbox"/>	<input type="checkbox"/>	<input type="checkbox"/>	<input type="checkbox"/>	<input type="checkbox"/>	<input type="checkbox"/>	<input type="checkbox"/>
7				蕪 8D63	<input type="checkbox"/>	<input type="checkbox"/>	<input type="checkbox"/>	櫟 8DC5	<input type="checkbox"/>	<input type="checkbox"/>	湫 8DF5	<input type="checkbox"/>	<input type="checkbox"/>	<input type="checkbox"/>	<input type="checkbox"/>	<input type="checkbox"/>
8				嶧 8D64	愷 8D74	擗 8DA6	<input type="checkbox"/>	<input type="checkbox"/>	沂 8DD6	<input type="checkbox"/>	<input type="checkbox"/>	<input type="checkbox"/>	<input type="checkbox"/>	<input type="checkbox"/>	<input type="checkbox"/>	<input type="checkbox"/>
9				<input type="checkbox"/>	<input type="checkbox"/>	<input type="checkbox"/>	拾 8DB7	<input type="checkbox"/>	<input type="checkbox"/>	<input type="checkbox"/>	<input type="checkbox"/>	<input type="checkbox"/>	<input type="checkbox"/>	<input type="checkbox"/>	<input type="checkbox"/>	<input type="checkbox"/>
A				<input type="checkbox"/>	<input type="checkbox"/>	<input type="checkbox"/>	<input type="checkbox"/>	<input type="checkbox"/>	<input type="checkbox"/>	<input type="checkbox"/>	<input type="checkbox"/>	<input type="checkbox"/>	<input type="checkbox"/>	<input type="checkbox"/>	<input type="checkbox"/>	<input type="checkbox"/>
B				嶺 8D67	<input type="checkbox"/>	<input type="checkbox"/>	<input type="checkbox"/>	<input type="checkbox"/>	<input type="checkbox"/>	<input type="checkbox"/>	<input type="checkbox"/>	<input type="checkbox"/>	<input type="checkbox"/>	<input type="checkbox"/>	<input type="checkbox"/>	<input type="checkbox"/>
C				帙 8D68	戟 8D78	<input type="checkbox"/>	裕 8DBA	糞 8DCA	<input type="checkbox"/>	<input type="checkbox"/>	<input type="checkbox"/>	<input type="checkbox"/>	<input type="checkbox"/>	<input type="checkbox"/>	<input type="checkbox"/>	<input type="checkbox"/>
D				<input type="checkbox"/>	<input type="checkbox"/>	敲 8DAB	榧 8DBB	<input type="checkbox"/>	淬 8DDB	澔 8DEB	偽 8DFB	<input type="checkbox"/>	<input type="checkbox"/>	么 C6CD	<input type="checkbox"/>	<input type="checkbox"/>
E				<input type="checkbox"/>	<input type="checkbox"/>	<input type="checkbox"/>	尙 8DBC	檠 8DCC	<input type="checkbox"/>	濶 8DEC	睥 8DFC	<input type="checkbox"/>	<input type="checkbox"/>	<input type="checkbox"/>	<input type="checkbox"/>	<input type="checkbox"/>
F				<input type="checkbox"/>	<input type="checkbox"/>	听 8DAD	<input type="checkbox"/>	<input type="checkbox"/>	<input type="checkbox"/>	<input type="checkbox"/>	噤 8DFD	<input type="checkbox"/>	<input type="checkbox"/>	<input type="checkbox"/>	<input type="checkbox"/>	<input type="checkbox"/>

	F70	F71	F72	F73	F74	F75	F76	F77	F78	F79	F7A	F7B	F7C	F7D	F7E	F7F
0	<input type="checkbox"/>	<input type="checkbox"/>	<input type="checkbox"/>	<input type="checkbox"/>	<input type="checkbox"/>	<input type="checkbox"/>	<input type="checkbox"/>	<input type="checkbox"/>	<input type="checkbox"/>	<input type="checkbox"/>	<input type="checkbox"/>	<input type="checkbox"/>	<input type="checkbox"/>	<input type="checkbox"/>	<input type="checkbox"/>	
1	<input type="checkbox"/>	<input type="checkbox"/>	<input type="checkbox"/>	<input type="checkbox"/>	<input type="checkbox"/>	<input type="checkbox"/>	<input type="checkbox"/>	<input type="checkbox"/>	<input type="checkbox"/>	<input type="checkbox"/>	<input type="checkbox"/>	<input type="checkbox"/>	<input type="checkbox"/>	<input type="checkbox"/>	<input type="checkbox"/>	
2	<input type="checkbox"/>	<input type="checkbox"/>	<input type="checkbox"/>	<input type="checkbox"/>	<input type="checkbox"/>	<input type="checkbox"/>	<input type="checkbox"/>	<input type="checkbox"/>	<input type="checkbox"/>	<input type="checkbox"/>	<input type="checkbox"/>	<input type="checkbox"/>	<input type="checkbox"/>	<input type="checkbox"/>	<input type="checkbox"/>	
3	<input type="checkbox"/>	<input type="checkbox"/>	<input type="checkbox"/>	<input type="checkbox"/>	<input type="checkbox"/>	<input type="checkbox"/>	<input type="checkbox"/>	<input type="checkbox"/>	<input type="checkbox"/>	<input type="checkbox"/>	<input type="checkbox"/>	<input type="checkbox"/>	<input type="checkbox"/>	<input type="checkbox"/>	<input type="checkbox"/>	
4	<input type="checkbox"/>	<input type="checkbox"/>	<input type="checkbox"/>	<input type="checkbox"/>	<input type="checkbox"/>	<input type="checkbox"/>	<input type="checkbox"/>	<input type="checkbox"/>	<input type="checkbox"/>	<input type="checkbox"/>	<input type="checkbox"/>	<input type="checkbox"/>	<input type="checkbox"/>	<input type="checkbox"/>	<input type="checkbox"/>	
5	<input type="checkbox"/>	<input type="checkbox"/>	<input type="checkbox"/>	<input type="checkbox"/>	<input type="checkbox"/>	<input type="checkbox"/>	<input type="checkbox"/>	<input type="checkbox"/>	<input type="checkbox"/>	<input type="checkbox"/>	<input type="checkbox"/>	<input type="checkbox"/>	<input type="checkbox"/>	<input type="checkbox"/>		
6	<input type="checkbox"/>	<input type="checkbox"/>	<input type="checkbox"/>	<input type="checkbox"/>	<input type="checkbox"/>	<input type="checkbox"/>	<input type="checkbox"/>	<input type="checkbox"/>	<input type="checkbox"/>	<input type="checkbox"/>	<input type="checkbox"/>	<input type="checkbox"/>	<input type="checkbox"/>	<input type="checkbox"/>		
7	<input type="checkbox"/>	<input type="checkbox"/>	<input type="checkbox"/>	<input type="checkbox"/>	<input type="checkbox"/>	<input type="checkbox"/>	<input type="checkbox"/>	<input type="checkbox"/>	<input type="checkbox"/>	<input type="checkbox"/>	<input type="checkbox"/>	<input type="checkbox"/>	<input type="checkbox"/>	<input type="checkbox"/>	<input type="checkbox"/>	
8	<input type="checkbox"/>	<input type="checkbox"/>	<input type="checkbox"/>	<input type="checkbox"/>	<input type="checkbox"/>	<input type="checkbox"/>	<input type="checkbox"/>	<input type="checkbox"/>	<input type="checkbox"/>	<input type="checkbox"/>	<input type="checkbox"/>	<input type="checkbox"/>	<input type="checkbox"/>	<input type="checkbox"/>		
9	<input type="checkbox"/>	<input type="checkbox"/>	<input type="checkbox"/>	<input type="checkbox"/>	<input type="checkbox"/>	<input type="checkbox"/>	<input type="checkbox"/>	<input type="checkbox"/>	<input type="checkbox"/>	<input type="checkbox"/>	<input type="checkbox"/>	<input type="checkbox"/>	<input type="checkbox"/>	<input type="checkbox"/>	<input type="checkbox"/>	
A	<input type="checkbox"/>	<input type="checkbox"/>	<input type="checkbox"/>	<input type="checkbox"/>	<input type="checkbox"/>	<input type="checkbox"/>	<input type="checkbox"/>	<input type="checkbox"/>	<input type="checkbox"/>	<input type="checkbox"/>	<input type="checkbox"/>	<input type="checkbox"/>	<input type="checkbox"/>	<input type="checkbox"/>		
B	<input type="checkbox"/>	<input type="checkbox"/>	<input type="checkbox"/>	<input type="checkbox"/>	<input type="checkbox"/>	<input type="checkbox"/>	<input type="checkbox"/>	<input type="checkbox"/>	<input type="checkbox"/>	<input type="checkbox"/>	<input type="checkbox"/>	<input type="checkbox"/>	<input type="checkbox"/>	<input type="checkbox"/>		
C	<input type="checkbox"/>	<input type="checkbox"/>	<input type="checkbox"/>	<input type="checkbox"/>	<input type="checkbox"/>	<input type="checkbox"/>	<input type="checkbox"/>	<input type="checkbox"/>	<input type="checkbox"/>	<input type="checkbox"/>	<input type="checkbox"/>	<input type="checkbox"/>	<input type="checkbox"/>	<input type="checkbox"/>	<input type="checkbox"/>	
D	<input type="checkbox"/>	<input type="checkbox"/>	<input type="checkbox"/>	<input type="checkbox"/>	<input type="checkbox"/>	<input type="checkbox"/>	<input type="checkbox"/>	<input type="checkbox"/>	<input type="checkbox"/>	<input type="checkbox"/>	<input type="checkbox"/>	<input type="checkbox"/>	<input type="checkbox"/>	<input type="checkbox"/>		
E	<input type="checkbox"/>	<input type="checkbox"/>	<input type="checkbox"/>	<input type="checkbox"/>	<input type="checkbox"/>	<input type="checkbox"/>	<input type="checkbox"/>	<input type="checkbox"/>	<input type="checkbox"/>	<input type="checkbox"/>	<input type="checkbox"/>	<input type="checkbox"/>	<input type="checkbox"/>	<input type="checkbox"/>		
F	<input type="checkbox"/>	<input type="checkbox"/>	<input type="checkbox"/>	<input type="checkbox"/>	<input type="checkbox"/>	<input type="checkbox"/>	<input type="checkbox"/>	<input type="checkbox"/>	<input type="checkbox"/>	<input type="checkbox"/>	<input type="checkbox"/>	<input type="checkbox"/>	<input type="checkbox"/>	<input type="checkbox"/>	<input type="checkbox"/>	

	F80	F81	F82	F83	F84	F85	F86	F87	F88	F89	F8A	F8B	F8C	F8D	F8E	F8F
0			𠄎 C8D6	𠄎 C8E6	<input type="checkbox"/>											
1			𠄏 C8D7	𠄏 C8E7	<input type="checkbox"/>											
2			𠄐 C8D8	𠄐 C8E8	<input type="checkbox"/>											
3			𠄑 C8D9	𠄑 C8E9	<input type="checkbox"/>											
4			𠄒 C8DA	𠄒 C8EA	<input type="checkbox"/>											
5			𠄓 C8DB	𠄓 C8EB	<input type="checkbox"/>											
6			𠄔 C8DC	𠄔 C8EC	<input type="checkbox"/>											
7		<input type="checkbox"/>	𠄕 C8DD	𠄕 C8ED	<input type="checkbox"/>											
8		<input type="checkbox"/>	𠄖 C8DE	𠄖 C8EE	<input type="checkbox"/>											
9		<input type="checkbox"/>	𠄗 C8DF	𠄗 C8EF												
A		<input type="checkbox"/>	𠄘 C8E0	𠄘 C8F0												
B		<input type="checkbox"/>	𠄙 C8E1	𠄙 C8F1												
C		<input type="checkbox"/>	𠄚 C8E2													
D		<input type="checkbox"/>	𠄛 C8E3													
E		<input type="checkbox"/>	𠄜 C8E4													
F		<input type="checkbox"/>	𠄝 C8E5	<input type="checkbox"/>												

Table 3.2 – Code Table of the HKSCS in the PUA of ISO 10646 v2.0

The following is an example of a typical cell in this table:

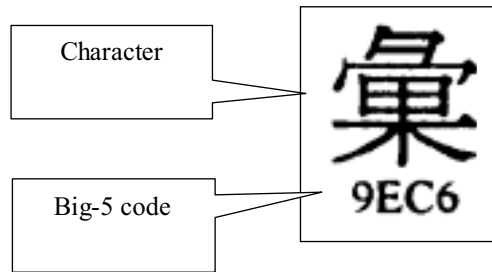

The following is an example of a cell representing a compatibility point in this table:

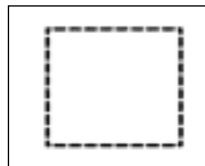

	E00	E01	E02	E03	E04	E05	E06	E07	E08	E09	E0A	E0B	E0C	E0D	E0E	E0F
0	宀 FA40		優 FA60	丕 FA70			匯 FAC2							壬 FB73		
1							滙 FAC3	却 FAD3								
2	逸 FA42	玳 FA52	傑 FA62	呔 FA72											咕 FBA7	亞 FBB7
3	瀟 FA43	鈞 FA53	傑 FA63	帽 FA73						巷 FAF5			萍 FB66		蕩 FBA8	
4		佻 FA54		倂 FA74			咍 FAC6	卿 FAD6		咍 FAF6				鷄 FB77	菴 FBA9	
5		茆 FA55	僚 FA65	循 FA75	礙 FAA7			侯 FAD7					墜 FB68	焜 FB78	媿 FBAA	
6		僂 FA56		覲 FA76			婁 FAC8				嫫 FB49					
7				勳 FA77					叡 FAE9		滫 FB4A		方望 FB6A		嫻 FBAC	
8		後 FA58		孛 FA78				鏹 FADA					燿 FB6B		嫫 FBAD	嫫 FBBD
9	珣 FA49								澄 FAEB	始 FAFB	熯 FB4C				赫 FBAE	律 FBBE
A	諄 FA4A	蓍 FA5A				芄 FABC			擡 FAEC	參 FAFC		鎊 FB5D	瑩 FB6D			
B		諱 FA5B		洑 FA7B								噯 FB4E			嫫 FBB0	嫫 FBC0
C	宥 FA4C	樛 FA5C		冰 FA7C	櫛 FAAE	鋤 FABE	妹 FACE		咍 FAEE	哲 FAFE		圯 FB5F		獎 FBA1	妣 FBB1	
D		璿 FA5D	琄 FA6D					稅 FADF		鎊 FB40						妣 FBC2
E	汕 FA4E	俸 FA5E	兒 FA6E							信 FB41	曝 FB51	灼 FB61			蕩 FBB3	
F						滙 FAC1								奮 FBA4		

	E10	E11	E12	E13	E14	E15	E16	E17	E18	E19	E1A	E1B	E1C	E1D	E1E	E1F
0	<input type="checkbox"/>	𪗇 FBD5	<input type="checkbox"/>	𪗈 FBF5	<input type="checkbox"/>	𪗉 FC56	<input type="checkbox"/>	<input type="checkbox"/>	𪗊 FCA8	嫁 FCB8	整 FCC8	𪗋 FCD8	<input type="checkbox"/>	<input type="checkbox"/>	<input type="checkbox"/>	𪗌 FD59
1	<input type="checkbox"/>	<input type="checkbox"/>	𪗍 FBE6	𪗎 FBF6	𪗏 FC47	<input type="checkbox"/>	<input type="checkbox"/>	慈 FC77	<input type="checkbox"/>	<input type="checkbox"/>	<input type="checkbox"/>	𪗐 FCD9	懼 FCE9	<input type="checkbox"/>	<input type="checkbox"/>	<input type="checkbox"/>
2	<input type="checkbox"/>	<input type="checkbox"/>	<input type="checkbox"/>	<input type="checkbox"/>	𪗑 FC48	<input type="checkbox"/>	𪗒 FC68	墓 FC78	<input type="checkbox"/>	<input type="checkbox"/>	<input type="checkbox"/>	<input type="checkbox"/>	<input type="checkbox"/>	<input type="checkbox"/>	𪗓 FD4B	𪗔 FD5B
3	說 FBC8	<input type="checkbox"/>	<input type="checkbox"/>	<input type="checkbox"/>	<input type="checkbox"/>	<input type="checkbox"/>	<input type="checkbox"/>	<input type="checkbox"/>	<input type="checkbox"/>	撮 FCBB	<input type="checkbox"/>	𪗖 FCDB	<input type="checkbox"/>	<input type="checkbox"/>	<input type="checkbox"/>	<input type="checkbox"/>
4	<input type="checkbox"/>	𪗘 FBD9	<input type="checkbox"/>	<input type="checkbox"/>	<input type="checkbox"/>	𪗙 FC5A	<input type="checkbox"/>	<input type="checkbox"/>	<input type="checkbox"/>	<input type="checkbox"/>	𪗚 FCCC	𪗛 FCDC	𪗜 FCEC	𪗝 FCFC	<input type="checkbox"/>	<input type="checkbox"/>
5	<input type="checkbox"/>	𪗞 FBDA	<input type="checkbox"/>	<input type="checkbox"/>	𪗟 FC4B	𪗠 FC5B	<input type="checkbox"/>	𪗡 FC7B	承 FCAD	𪗢 FCBD	<input type="checkbox"/>	<input type="checkbox"/>	𪗣 FCED	𪗤 FCFD	<input type="checkbox"/>	<input type="checkbox"/>
6	𪗦 FBCB	<input type="checkbox"/>	𪗧 FBEB	𪗨 FBFB	<input type="checkbox"/>	𪗩 FC5C	<input type="checkbox"/>	<input type="checkbox"/>	<input type="checkbox"/>	𪗫 FCBE	𪗬 FCCE	𪗭 FCDE	<input type="checkbox"/>	<input type="checkbox"/>	𪗮 FD4F	<input type="checkbox"/>
7	<input type="checkbox"/>	<input type="checkbox"/>	𪗱 FBEC	<input type="checkbox"/>	𪗲 FC4D	𪗳 FC5D	<input type="checkbox"/>	<input type="checkbox"/>	𪗵 FCAF	<input type="checkbox"/>	<input type="checkbox"/>	<input type="checkbox"/>	<input type="checkbox"/>	𪗷 FD40	<input type="checkbox"/>	𪗸 FD60
8	<input type="checkbox"/>	<input type="checkbox"/>	𪗹 FBED	<input type="checkbox"/>	𪗺 FC4E	<input type="checkbox"/>	𪗻 FC6E	𪗼 FC7E	<input type="checkbox"/>	<input type="checkbox"/>	<input type="checkbox"/>	𪗽 FCE0	𪗾 FCF0	<input type="checkbox"/>	<input type="checkbox"/>	<input type="checkbox"/>
9	𪗿 FBCE	<input type="checkbox"/>	<input type="checkbox"/>	𪗿 FBFE	<input type="checkbox"/>	𪗿 FC5F	𪗿 FC6F	𪗿 FCA1	𪗿 FCB1	<input type="checkbox"/>	<input type="checkbox"/>	<input type="checkbox"/>	<input type="checkbox"/>	<input type="checkbox"/>	<input type="checkbox"/>	<input type="checkbox"/>
A	𪗿 FBCF	<input type="checkbox"/>	<input type="checkbox"/>	<input type="checkbox"/>	𪗿 FC50	𪗿 FC60	𪗿 FC70	<input type="checkbox"/>	<input type="checkbox"/>	<input type="checkbox"/>	𪗿 FCD2	<input type="checkbox"/>	<input type="checkbox"/>	𪗿 FD43	<input type="checkbox"/>	𪗿 FD63
B	𪗿 FBD0	<input type="checkbox"/>	<input type="checkbox"/>	<input type="checkbox"/>	<input type="checkbox"/>	<input type="checkbox"/>	<input type="checkbox"/>	𪗿 FCA3	𪗿 FCB3	<input type="checkbox"/>	<input type="checkbox"/>	𪗿 FCE3	<input type="checkbox"/>	<input type="checkbox"/>	𪗿 FD54	<input type="checkbox"/>
C	<input type="checkbox"/>	𪗿 FBE1	<input type="checkbox"/>	<input type="checkbox"/>	<input type="checkbox"/>	<input type="checkbox"/>	<input type="checkbox"/>	𪗿 FCA4	<input type="checkbox"/>	<input type="checkbox"/>	<input type="checkbox"/>	𪗿 FCE4	𪗿 FCF4	<input type="checkbox"/>	<input type="checkbox"/>	<input type="checkbox"/>
D	<input type="checkbox"/>	𪗿 FBE2	<input type="checkbox"/>	<input type="checkbox"/>	𪗿 FC53	𪗿 FC63	<input type="checkbox"/>	<input type="checkbox"/>	<input type="checkbox"/>	<input type="checkbox"/>	<input type="checkbox"/>	𪗿 FCE5	𪗿 FCF5	𪗿 FD46	<input type="checkbox"/>	<input type="checkbox"/>
E	<input type="checkbox"/>	<input type="checkbox"/>	<input type="checkbox"/>	<input type="checkbox"/>	<input type="checkbox"/>	<input type="checkbox"/>	<input type="checkbox"/>	<input type="checkbox"/>	<input type="checkbox"/>	<input type="checkbox"/>	𪗿 FCD6	𪗿 FCE6	<input type="checkbox"/>	<input type="checkbox"/>	<input type="checkbox"/>	𪗿 FD67
F	<input type="checkbox"/>	<input type="checkbox"/>	<input type="checkbox"/>	<input type="checkbox"/>	<input type="checkbox"/>	<input type="checkbox"/>	<input type="checkbox"/>	𪗿 FCA7	𪗿 FCB7	𪗿 FCC7	<input type="checkbox"/>	𪗿 FCE7	<input type="checkbox"/>	<input type="checkbox"/>	𪗿 FD58	<input type="checkbox"/>

	E20	E21	E22	E23	E24	E25	E26	E27	E28	E29	E2A	E2B	E2C	E2D	E2E	E2F
0	穀 FD69	滂 FD79	落 FDAB							咍 FESC					龠 FECE	致 FEDE
1	倭 FD6A		薄 FDAC	游 FDBC		瀨 FDDC	燄 FDEC	鑄 FDFC		舩 FE5D	涸 FE6D		隄 FEAF		會 FECF	璫 FEDF
2	孛 FD6B	滂 FD7B				瀛 FDDD			卒 FE4E			濤 FE7E			嶺 FED0	
3		炆 FD7C		潛 FDBE		瀛 FDDE						灑 FEA1				
4		玃 FD7D				縑 FDDF				焯 FE60	璵 FE70	璧 FEA2		玃 FEC2		
5	匏 FD6E	玃 FD7E			霽 FDD0					姦 FE61		鏢 FEA3				
6		叕 FDA1	琚 FDB1							璆 FE62	隅 FE72					
7	滄 FD70		澗 FDB2	斂 FDC2								鏗 FEA5	琬 FEB5		睿 FED5	
8			滄 FDB3		灑 FDD3		煦 FDF3		猴 FE54			嫫 FEA6		皋 FEC6		礪 FEE6
9		啖 FDA4							猷 FE55	珩 FE65			疋 FEB7	臯 FEC7	瞬 FED7	
A	衫 FD73		靖 FDB5		灑 FDD5			爪 FE46		珮 FE66		龠 FEA8				
B	玳 FD74	滂 FDA6		澗 FDC6	灑 FDD6		焄 FDF6		猷 FE57	琿 FE67					舒 FED9	
C	苈 FD75	彬 FDA7			濬 FDD7										鈔 FEDA	初 FEEA
D				灑 FDC8	濬 FDD8		燈 FDF8	琿 FE49							物 FEDB	
E				漪 FDC9	灑 FDD9		璪 FDF9					隄 FEAC		蓋 FECC		
F		菡 FDAA	鏢 FDAB		灑 FDDA		璪 FDFA			琦 FE6B		穹 FEAD				釧 FEED

	E30	E31	E32	E33	E34	E35	E36	E37	E38	E39	E3A	E3B	E3C	E3D	E3E	E3F
0	罇 FEFE			瞞 8E5F			嫵 8EB1				涇 8EF1					蓀 8FA4
1	伺 FEFF	滂 8E40		筠 8E60					鶻 8ED2	慙 8EE2		唅 8F43			篔 8F73	
2					簾 8E71	縉 8EA3	轉 8EB3	羌 8EC3	韞 8ED3		壥 8EF3	婁 8F44				夔 8FA6
3		稯 8E42								翻 8EE4			娥 8F55	箒 8F75	夔 8FA7	
4						蒟 8EA5	縵 8EB5	羨 8EC5		瞞 8EE5		崑 8F46				夔 8FA8
5		稽 8E44	翻 8E54	筱 8E64	獐 8E74		繇 8EB6	冲 8EC6			芑 8EF6	棧 8F47		沢 8F67		
6	穉 FEF4			莪 8E65					恕 8ED7	舉 8EE7	玳 8EF7					
7								櫻 8EC8			棧 8EF8				犂 8F79	
8	禮 FEF6	鑄 8E47			脏 8E77				肇 8ED9	嬋 8EE9	婁 8EF9		夔 8F5A	芟 8F6A		嬋 8FAC
9								翰 8ECA	澗 8EDA		苳 8EFA	漑 8F4B		蓓 8F6B		
A									勝 8EDB	璦 8EEB		蒧 8F4C		滂 8F6C		蝦 8FAE
B		穉 8E4A		纂 8E6A		漑 8EAC		熠 8ECC		璦 8EEC		芑 8F4D				
C	藪 FEFA	穎 8E4B	旌 8E5B			緞 8EAD					芴 8EFD	茵 8F4E	稊 8F5E			
D				篠 8E6C					錯 8EDE			橙 8F4F	孛 8F5F		遼 8FA1	鶻 8FB1
E										媿 8EEF					遼 8FA2	
F	穉 FEFD	畚 8E4E					罩 8EC0			艇 8EF0			箒 8F61			游 8FB3

	E40	E41	E42	E43	E44	E45	E46	E47	E48	E49	E4A	E4B	E4C	E4D	E4E	E4F
0					賚 8FF4	躡 9045										
1					賜 8FF5	藁 9046	鋤 9056	遶 9066		鎚 90A8	怵 90B8		璫 90D8			
2				璿 8FE6			迦 9057	遶 9067		鑿 90A9	邨 90B9					
3			誕 8FD7				洩 9058				坩 90BA	菌 90CA				
4		裘 8FC8			嬪 8FF8			郟 9069	礪 9079		滄 90BB	倆 90CB			龔 90FB	
5			諱 8FD9				睇 905A			鑲 90AC		叟 90CC				
6			漪 8FDA	娥 8FEA				毳 906B	錠 907B	鑿 90AD		禱 90CD	彰 90DD	𦉳 90ED	𦉴 90FD	璫 914E
7							駘 905C		汞 907C	鑿 90AE		霽 90CE			灑 90FE	
8			譚 8FDC		嘆 8FFC		誦 905D		鏡 907D			瓊 90CF			毓 9140	馥 9150
9	衍 8FBD					輓 904E	適 905E		礪 907E			嬪 90D0	孛 90E0	韻 90F0		駟 9151
A	淅 8FBE			賁 8FEE		𦉵 904F	𦉶 905F		咽 90A1			曠 90D1				
B	衍 8FBF	鏊 8FCF		賁 8FEF							蔭 90C2					
C			𦉷 8FE0	賁 8FF0	𦉸 9041		蕙 9061								韻 90F3	
D		𦉹 8FD1	𦉺 8FE1		𦉻 9042	𦉼 9052			鍵 90A4				𦉽 90E4	韻 90F4		
E		譜 8FD2		昭 8FE2	璫 9043	辰 9053	遊 9063	釐 9073	鑄 90A5				𦉽 90E5		蕙 9146	
F							𦉾 9064	崖 9074			錐 90C6				𦉿 9147	襪 9157

	E50	E51	E52	E53	E54	E55	E56	E57	E58	E59	E5A	E5B	E5C	E5D	E5E	E5F
0	<input type="text"/>	<input type="text"/>	鴻 9178	<input type="text"/>	<input type="text"/>	<input type="text"/>	<input type="text"/>	媿 91EA	媿 91FA	蘩 924B	滌 925B	<input type="text"/>	徒 927B	<input type="text"/>	<input type="text"/>	琤 92CD
1	霰 9159	<input type="text"/>	鷺 9179	<input type="text"/>	<input type="text"/>	<input type="text"/>	<input type="text"/>	<input type="text"/>	<input type="text"/>	<input type="text"/>	郝 925C	儻 926C	<input type="text"/>	<input type="text"/>	尅 92BE	懶 92CE
2	鬚 915A	鷓 916A	<input type="text"/>	<input type="text"/>	<input type="text"/>	<input type="text"/>	鋃 91DC	嫫 91EC	琦 91FC	櫛 924D	<input type="text"/>	價 926D	丛 927D	<input type="text"/>	剋 92BF	<input type="text"/>
3	<input type="text"/>	<input type="text"/>	<input type="text"/>	<input type="text"/>	航 91BD	<input type="text"/>	<input type="text"/>	槎 91ED	埼 91FD	鬻 924E	<input type="text"/>	<input type="text"/>	<input type="text"/>	<input type="text"/>	尅 92C0	唳 92D0
4	<input type="text"/>	嫫 916C	鷺 917C	<input type="text"/>	<input type="text"/>	琰 91CE	<input type="text"/>	<input type="text"/>	垓 91FE	蓋 924F	眇 925F	<input type="text"/>	<input type="text"/>	<input type="text"/>	<input type="text"/>	<input type="text"/>
5	髯 915D	<input type="text"/>	<input type="text"/>	<input type="text"/>	<input type="text"/>	琬 91CF	<input type="text"/>	嫫 91EF	塍 9240	<input type="text"/>	<input type="text"/>	祧 9270	<input type="text"/>	<input type="text"/>	鏗 92C2	<input type="text"/>
6	<input type="text"/>	丞 916E	<input type="text"/>	<input type="text"/>	<input type="text"/>	<input type="text"/>	釜 91E0	砣 91F0	壤 9241	<input type="text"/>	聃 9261	<input type="text"/>	<input type="text"/>	<input type="text"/>	剋 92C3	<input type="text"/>
7	<input type="text"/>	<input type="text"/>	<input type="text"/>	焯 91B1	<input type="text"/>	瑨 91D1	燿 91E1	媿 91F1	<input type="text"/>	<input type="text"/>	奶 9262	仵 9272	<input type="text"/>	榭 92B4	<input type="text"/>	<input type="text"/>
8	<input type="text"/>	<input type="text"/>	龍 91A2	<input type="text"/>	<input type="text"/>	燈 91D2	<input type="text"/>	<input type="text"/>	槿 9243	<input type="text"/>	嘆 9263	僂 9273	塚 92A5	滢 92B5	<input type="text"/>	<input type="text"/>
9	<input type="text"/>	<input type="text"/>	鸚 91A3	<input type="text"/>	<input type="text"/>	玦 91D3	<input type="text"/>	咏 91F3	<input type="text"/>	<input type="text"/>	<input type="text"/>	<input type="text"/>	涿 92A6	滢 92B6	劬 92C6	<input type="text"/>
A	頤 9162	鰕 9172	鸚 91A4	<input type="text"/>	<input type="text"/>	<input type="text"/>	<input type="text"/>	媿 91F4	<input type="text"/>	嫫 9255	鋏 9265	耙 9275	<input type="text"/>	<input type="text"/>	<input type="text"/>	<input type="text"/>
B	<input type="text"/>	<input type="text"/>	鸚 91A5	<input type="text"/>	霁 91C5	鑊 91D5	<input type="text"/>	<input type="text"/>	琿 9246	<input type="text"/>	<input type="text"/>	魯 9276	<input type="text"/>	媿 92B8	<input type="text"/>	瑾 92D8
C	<input type="text"/>	鳩 9174	驪 91A6	<input type="text"/>	<input type="text"/>	媿 91D6	<input type="text"/>	媿 91F6	馨 9247	<input type="text"/>	<input type="text"/>	<input type="text"/>	<input type="text"/>	淋 92B9	<input type="text"/>	瀧 92D9
D	燄 9165	鴈 9175	<input type="text"/>	<input type="text"/>	<input type="text"/>	<input type="text"/>	燻 91E7	媿 91F7	滌 9248	櫛 9258	<input type="text"/>	<input type="text"/>	<input type="text"/>	<input type="text"/>	<input type="text"/>	<input type="text"/>
E	<input type="text"/>	鰕 9176	鸚 91A8	鑊 91B8	<input type="text"/>	鈿 91D8	燻 91E8	檢 91F8	磽 9249	瀨 9259	<input type="text"/>	儻 9279	<input type="text"/>	<input type="text"/>	燻 92CB	<input type="text"/>
F	魁 9167	鴻 9177	慶 91A9	<input type="text"/>	<input type="text"/>	阡 91D9	<input type="text"/>	<input type="text"/>	澆 924A	灤 925A	燻 926A	隕 927A	<input type="text"/>	溘 92BC	呬 92CC	<input type="text"/>

	E60	E61	E62	E63	E64	E65	E66	E67	E68	E69	E6A	E6B	E6C	E6D	E6E	E6F
0	瀝 92DD	委 92ED			颯 935E		霽 937E		暝 93C0	煜 93D0			肆 9441		玗 9461	
1		婁 92EE	糅 92FE		楓 935F			揜 93B1			櫛 93E1		鄒 9442	焯 9452	緄 9462	
2	倭 92DF	媵 92EF		滿 9350	佩 9360	仇 9370	犓 93A2			莢 93D2	棧 93E2	孌 93F2		焠 9453		曉 9473
3			鏗 9341	預 9351		仇 9371	抗 93A3		礩 93C3							曠 9474
4	叟 92E1		愷 9342	毒 9352		悉 9372			鏤 93C4						瓏 9465	
5					嬪 9363	蕙 9373	吊 93A5		礪 93C5				璽 9446		鑷 9466	
6					嫪 9364		柁 93A6	漣 93B6	妊 93C6	覬 93D6	柝 93E6				漑 9467	
7			培 9345	嬈 9355		套 9375	駟 93A7	畀 93B7	礎 93C7	晟 93D7			澀 9448	狃 9458		齋 9478
8				嬈 9356	妹 9366	盍 9376	攬 93A8	聖 93B8	礪 93C8					玃 9459		
9		窈 92F6				忤 9377		畀 93B9		曄 93D9		漙 93F9				
A		宓 92F7		嬈 9358			黻 93AA		旗 93CA	矇 93DA		洵 93FA	潑 944B	璫 945B		鐳 947B
B		嫵 92F8	鋹 9349		衡 9369			濟 93BB	嫵 93CB					渙 945C		琤 947C
C		焯 92F9		媼 935A				濟 93BC	瞄 93CC	穉 93DC	櫟 93EC					琿 947D
D						搥 937B		韻 93BD			燦 93ED	鏞 93FD		滄 945E		
E					懺 936C	擻 937C	璉 93AE		暗 93CE	檢 93DE		鎮 93FE		常 945F	菱 946F	
F	鍼 92EC			鏞 935D	恚 936D	犖 937D	擻 93AF	噉 93BF	昱 93CF	檣 93DF				瑯 9460		璫 94A2

	E70	E71	E72	E73	E74	E75	E76	E77	E78	E79	E7A	E7B	E7C	E7D	E7E	E7F
0	<input type="checkbox"/>	惓 94B3	<input type="checkbox"/>	<input type="checkbox"/>	惓 94E3	<input type="checkbox"/>	<input type="checkbox"/>	簾 9554	<input type="checkbox"/>	嫵 9574	<input type="checkbox"/>	<input type="checkbox"/>	<input type="checkbox"/>	<input type="checkbox"/>	<input type="checkbox"/>	<input type="checkbox"/>
1	珽 94A4	櫟 94B4	<input type="checkbox"/>	<input type="checkbox"/>	嫵 94E4	璘 94F4	莘 9545	<input type="checkbox"/>	<input type="checkbox"/>	<input type="checkbox"/>	<input type="checkbox"/>	黠 95B7	<input type="checkbox"/>	珽 95D7	<input type="checkbox"/>	琇 95F7
2	玕 94A5	<input type="checkbox"/>	<input type="checkbox"/>	<input type="checkbox"/>	醇 94E5	嫵 94F5	聿 9546	<input type="checkbox"/>	<input type="checkbox"/>	嫵 9576	裡 95A8	<input type="checkbox"/>	<input type="checkbox"/>	<input type="checkbox"/>	<input type="checkbox"/>	璘 95F8
3	<input type="checkbox"/>	吐 94B6	<input type="checkbox"/>	喧 94D6	<input type="checkbox"/>	<input type="checkbox"/>	<input type="checkbox"/>	<input type="checkbox"/>	<input type="checkbox"/>	<input type="checkbox"/>	<input type="checkbox"/>	<input type="checkbox"/>	<input type="checkbox"/>	<input type="checkbox"/>	<input type="checkbox"/>	漭 95F9
4	<input type="checkbox"/>	<input type="checkbox"/>	禰 94C7	瑄 94D7	佻 94E7	<input type="checkbox"/>	準 9548	<input type="checkbox"/>	臄 9568	嫵 9578	禰 95AA	焜 95BA	鬲 95CA	<input type="checkbox"/>	閔 95EA	<input type="checkbox"/>
5	<input type="checkbox"/>	<input type="checkbox"/>	帶 94C8	值 94D8	<input type="checkbox"/>	<input type="checkbox"/>	榨 9549	柀 9559	<input type="checkbox"/>	<input type="checkbox"/>	轡 95AB	<input type="checkbox"/>	<input type="checkbox"/>	<input type="checkbox"/>	<input type="checkbox"/>	<input type="checkbox"/>
6	璠 94A9	<input type="checkbox"/>	<input type="checkbox"/>	涓 94D9	<input type="checkbox"/>	<input type="checkbox"/>	<input type="checkbox"/>	<input type="checkbox"/>	旋 956A	蜨 957A	鏗 95AC	<input type="checkbox"/>	<input type="checkbox"/>	<input type="checkbox"/>	<input type="checkbox"/>	<input type="checkbox"/>
7	嫵 94AA	璠 94BA	<input type="checkbox"/>	媼 94DA	綰 94EA	<input type="checkbox"/>	羿 954B	珽 955B	<input type="checkbox"/>	漭 957B	鏗 95AD	<input type="checkbox"/>	<input type="checkbox"/>	<input type="checkbox"/>	玕 95ED	<input type="checkbox"/>
8	<input type="checkbox"/>	燕 94BB	<input type="checkbox"/>	<input type="checkbox"/>	<input type="checkbox"/>	<input type="checkbox"/>	弛 954C	踰 955C	<input type="checkbox"/>	<input type="checkbox"/>	璠 95AE	鳩 95BE	<input type="checkbox"/>	鍔 95DE	璠 95EE	璠 95FE
9	瞭 94AC	<input type="checkbox"/>	<input type="checkbox"/>	<input type="checkbox"/>	<input type="checkbox"/>	<input type="checkbox"/>	皓 954D	<input type="checkbox"/>	棘 956D	螻 957D	鋤 95AF	<input type="checkbox"/>	<input type="checkbox"/>	<input type="checkbox"/>	燐 95EF	<input type="checkbox"/>
A	瞭 94AD	璠 94BD	<input type="checkbox"/>	<input type="checkbox"/>	<input type="checkbox"/>	<input type="checkbox"/>	<input type="checkbox"/>	睽 955E	<input type="checkbox"/>	<input type="checkbox"/>	<input type="checkbox"/>	<input type="checkbox"/>	廻 95D0	鏗 95E0	<input type="checkbox"/>	<input type="checkbox"/>
B	<input type="checkbox"/>	繳 94BE	湛 94CE	<input type="checkbox"/>	<input type="checkbox"/>	<input type="checkbox"/>	躑 94FE	<input type="checkbox"/>	裴 956F	<input type="checkbox"/>	<input type="checkbox"/>	<input type="checkbox"/>	<input type="checkbox"/>	<input type="checkbox"/>	踰 95F1	零 9642
C	睽 94AF	<input type="checkbox"/>	<input type="checkbox"/>	任 94DF	<input type="checkbox"/>	縉 9540	窺 9550	藹 9560	<input type="checkbox"/>	<input type="checkbox"/>	<input type="checkbox"/>	賄 95C2	<input type="checkbox"/>	鐮 95E2	<input type="checkbox"/>	馱 9643
D	<input type="checkbox"/>	磚 94C0	<input type="checkbox"/>	吐 94E0	筮 94F0	譚 9541	笱 9551	某 9561	餽 9571	<input type="checkbox"/>	<input type="checkbox"/>	<input type="checkbox"/>	<input type="checkbox"/>	鍔 95E3	陷 95F3	<input type="checkbox"/>
E	<input type="checkbox"/>	<input type="checkbox"/>	<input type="checkbox"/>	<input type="checkbox"/>	漚 94F1	<input type="checkbox"/>	簾 9552	<input type="checkbox"/>	<input type="checkbox"/>	<input type="checkbox"/>	<input type="checkbox"/>	<input type="checkbox"/>	媼 95D4	<input type="checkbox"/>	隄 95F4	<input type="checkbox"/>
F	<input type="checkbox"/>	<input type="checkbox"/>	炳 94D2	<input type="checkbox"/>	粘 94F2	糲 9543	<input type="checkbox"/>	<input type="checkbox"/>	<input type="checkbox"/>	<input type="checkbox"/>	<input type="checkbox"/>	<input type="checkbox"/>	<input type="checkbox"/>	<input type="checkbox"/>	隄 95F5	鍊 9646

	E80	E81	E82	E83	E84	E85	E86	E87	E88	E89	E8A	E8B	E8C	E8D	E8E	E8F
0	鑛 9647						蔭 96C9				嫫 974A	鏢 975A	潔 976A	鑣 977A	斲 97AC	
1	鐸 9648	頽 9658	譚 9668		楓 96AA	鴻 96BA	薈 96CA	倌 96DA		菁 96FA	嚙 974B		儻 976B	礪 977B	斲 97AD	鏢 97BD
2	癩 9649				懇 96AB		淳 96CB			煌 96FB			潔 976C			嫫 97BE
3		颯 965A									妹 974D		望 976D	鏢 977D		
4										煥 96FD	墟 974E					
5				塗 967C		鷄 96BE	基 96CE			換 96FE	煩 974F	鏢 975F	珮 976F	玟 97A1	鏢 97B1	歷 97C1
6		鐸 965D				鵠 96BF	樺 96CF				搥 9750	熨 9760		呢 97A2	璿 97B2	
7		瑄 965E	鏢 966E	琛 967E		鶯 96C0	綫 96D0		炆 96F0		灑 9751		琊 9771			
8	炆 964F	鏢 965F	稜 966F	壘 96A1		鶯 96C1		礪 96E1				璿 9762		溼 97A4	嫫 97B4	
9							榘 96D2				焱 9753			吠 97A5	媧 97B5	
A		鏢 9661		惘 96A3			榘 96D3			熨 9744	棋 9754			喞 97A6	媧 97B6	
B				溼 96A4	鯨 96B4	蔞 96C4							蠡 9775			埔 97C7
C	曼 9653					綺 96C5	璞 96D5				縹 9756					
D			駭 9674		鸕 96B6	菅 96C6		媧 96E6		鏢 9747	緝 9757	瓊 9767	鏢 9777	媧 97A9	透 97B9	
E	鏢 9655				鵠 96B7			晤 96E7			瑱 9758	璿 9768	鏢 9778			躬 97CA
F	瑪 9656		駭 9676					珞 96E8	炆 96F8		璿 9759	媧 9769		媧 97AB		

	E90	E91	E92	E93	E94	E95	E96	E97	E98	E99	E9A	E9B	E9C	E9D	E9E	E9F
0	霄 97CC		戴 97EC			焯 985D	焯 986D					昧 98DF				
1			垤 97ED		嫫 984E		埤 986E		鎰 98B0	玕 98C0						
2			汲 97EE			澀 985F			馱 98B1							
3	贖 97CF			蓉 9840		裡 9860		鎔 98A2								
4				蒨 9841	嫻 9851	爇 9861	勳 9871	曦 98A3								
5			堧 97F1	蒨 9842	焯 9852	焯 9862		金 98A4								
6			梁 97F2	蕙 9843												
7	漾 97D3	鑄 97E3	登 97F3			焯 9864	勇 9874	甸 98A6	謹 98B6							
8	溼 97D4	莖 97E4	擘 97F4	蕙 9845	姻 9855	鋸 9865	璿 9875	灤 98A7								
9			鎔 97F5													
A			櫛 97F6	媧 9847		蓓 9867		曦 98A9	禧 98B9							
B			杺 97F7					甌 98AA					磁 98FA			
C	佩 97D8	墩 97E8	晴 97F8	蓓 9849		爇 9869										
D				蕙 984A	焯 985A	爇 986A		霽 98AC								
E		壘 97EA	櫛 97FA	媧 984B		焯 986B	璿 987B		調 98BD							
F		壘 97EB	蒨 97FB				媧 987C								吡 995F	

	EA0	EA1	EA2	EA3	EA4	EA5	EA6	EA7	EA8	EA9	EAA	EAB	EAC	EAD	EAE	EAF	
0	<input type="checkbox"/>	<input type="checkbox"/>	<input type="checkbox"/>	<input type="checkbox"/>	<input type="checkbox"/>	<input type="checkbox"/>	<input type="checkbox"/>	<input type="checkbox"/>	<input type="checkbox"/>	<input type="checkbox"/>	<input type="checkbox"/>	<input type="checkbox"/>	傲 9AB5	贖 9AC5	唳 9AD5	嗚 9AE5	
1	<input type="checkbox"/>	<input type="checkbox"/>	<input type="checkbox"/>	<input type="checkbox"/>	<input type="checkbox"/>	<input type="checkbox"/>	<input type="checkbox"/>	<input type="checkbox"/>	<input type="checkbox"/>	<input type="checkbox"/>	<input type="checkbox"/>	<input type="checkbox"/>	儻 9AB6	吶 9AC6	唳 9AD6	噤 9AE6	
2	<input type="checkbox"/>	<input type="checkbox"/>	<input type="checkbox"/>	<input type="checkbox"/>	<input type="checkbox"/>	<input type="checkbox"/>	<input type="checkbox"/>	<input type="checkbox"/>	<input type="checkbox"/>	<input type="checkbox"/>	<input type="checkbox"/>	<input type="checkbox"/>	<input type="checkbox"/>	<input type="checkbox"/>	嘔 9AD7	噤 9AE7	
3	<input type="checkbox"/>	<input type="checkbox"/>	<input type="checkbox"/>	<input type="checkbox"/>	齋 99D5	<input type="checkbox"/>	<input type="checkbox"/>	<input type="checkbox"/>	<input type="checkbox"/>	<input type="checkbox"/>	<input type="checkbox"/>	<input type="checkbox"/>	<input type="checkbox"/>	呌 9AC8	嘖 9AD8	<input type="checkbox"/>	
4	<input type="checkbox"/>	<input type="checkbox"/>	<input type="checkbox"/>	<input type="checkbox"/>	<input type="checkbox"/>	<input type="checkbox"/>	<input type="checkbox"/>	<input type="checkbox"/>	<input type="checkbox"/>	<input type="checkbox"/>	<input type="checkbox"/>	<input type="checkbox"/>	<input type="checkbox"/>	吟 9AC9	<input type="checkbox"/>	噤 9AE9	
5	<input type="checkbox"/>	<input type="checkbox"/>	<input type="checkbox"/>	<input type="checkbox"/>	<input type="checkbox"/>	<input type="checkbox"/>	<input type="checkbox"/>	<input type="checkbox"/>	<input type="checkbox"/>	<input type="checkbox"/>	<input type="checkbox"/>	<input type="checkbox"/>	兔兔 9ABA	<input type="checkbox"/>	<input type="checkbox"/>	嘖 9AEA	
6	<input type="checkbox"/>	<input type="checkbox"/>	<input type="checkbox"/>	<input type="checkbox"/>	<input type="checkbox"/>	<input type="checkbox"/>	<input type="checkbox"/>	<input type="checkbox"/>	<input type="checkbox"/>	<input type="checkbox"/>	<input type="checkbox"/>	<input type="checkbox"/>	<input type="checkbox"/>	吻 9ACB	<input type="checkbox"/>	嘖 9AEB	
7	<input type="checkbox"/>	<input type="checkbox"/>	<input type="checkbox"/>	<input type="checkbox"/>	<input type="checkbox"/>	<input type="checkbox"/>	<input type="checkbox"/>	<input type="checkbox"/>	<input type="checkbox"/>	<input type="checkbox"/>	<input type="checkbox"/>	<input type="checkbox"/>	<input type="checkbox"/>	吻 9ACC	啖 9ADC	<input type="checkbox"/>	
8	<input type="checkbox"/>	<input type="checkbox"/>	<input type="checkbox"/>	<input type="checkbox"/>	<input type="checkbox"/>	<input type="checkbox"/>	<input type="checkbox"/>	<input type="checkbox"/>	<input type="checkbox"/>	<input type="checkbox"/>	<input type="checkbox"/>	<input type="checkbox"/>	<input type="checkbox"/>	啖 9ACD	啖 9ADD	啖 9AED	
9	<input type="checkbox"/>	<input type="checkbox"/>	<input type="checkbox"/>	<input type="checkbox"/>	<input type="checkbox"/>	<input type="checkbox"/>	<input type="checkbox"/>	<input type="checkbox"/>	<input type="checkbox"/>	<input type="checkbox"/>	允 9A7C	<input type="checkbox"/>	浚 9ABE	哂 9ACE	啖 9ADE	啖 9AEE	
A	<input type="checkbox"/>	<input type="checkbox"/>	<input type="checkbox"/>	<input type="checkbox"/>	<input type="checkbox"/>	<input type="checkbox"/>	<input type="checkbox"/>	<input type="checkbox"/>	<input type="checkbox"/>	<input type="checkbox"/>	<input type="checkbox"/>	<input type="checkbox"/>	灑 9ABF	啖 9ACF	啖 9ADF	噤 9AEF	
B	<input type="checkbox"/>	<input type="checkbox"/>	<input type="checkbox"/>	<input type="checkbox"/>	<input type="checkbox"/>	<input type="checkbox"/>	<input type="checkbox"/>	<input type="checkbox"/>	<input type="checkbox"/>	<input type="checkbox"/>	<input type="checkbox"/>	<input type="checkbox"/>	𠵼 9AC0	<input type="checkbox"/>	啖 9AE0	啖 9AF0	
C	<input type="checkbox"/>	<input type="checkbox"/>	<input type="checkbox"/>	<input type="checkbox"/>	<input type="checkbox"/>	<input type="checkbox"/>	<input type="checkbox"/>	<input type="checkbox"/>	<input type="checkbox"/>	<input type="checkbox"/>	<input type="checkbox"/>	<input type="checkbox"/>	𠵼 9AC1	𠵼 9AD1	啖 9AE1	<input type="checkbox"/>	
D	<input type="checkbox"/>	<input type="checkbox"/>	<input type="checkbox"/>	<input type="checkbox"/>	<input type="checkbox"/>	<input type="checkbox"/>	<input type="checkbox"/>	<input type="checkbox"/>	<input type="checkbox"/>	<input type="checkbox"/>	<input type="checkbox"/>	<input type="checkbox"/>	<input type="checkbox"/>	<input type="checkbox"/>	<input type="checkbox"/>	<input type="checkbox"/>	
E	<input type="checkbox"/>	<input type="checkbox"/>	<input type="checkbox"/>	<input type="checkbox"/>	<input type="checkbox"/>	<input type="checkbox"/>	<input type="checkbox"/>	<input type="checkbox"/>	<input type="checkbox"/>	<input type="checkbox"/>	<input type="checkbox"/>	<input type="checkbox"/>	<input type="checkbox"/>	<input type="checkbox"/>	啖 9AD3	啖 9AE3	啖 9AF3
F	<input type="checkbox"/>	<input type="checkbox"/>	<input type="checkbox"/>	<input type="checkbox"/>	<input type="checkbox"/>	<input type="checkbox"/>	<input type="checkbox"/>	<input type="checkbox"/>	<input type="checkbox"/>	<input type="checkbox"/>	<input type="checkbox"/>	𠵼 9AB4	廬 9AC4	𠵼 9AD4	<input type="checkbox"/>	啖 9AF4	

	EB0	EB1	EB2	EB3	EB4	EB5	EB6	EB7	EB8	EB9	EBA	EBB	EBC	EBD	EBE	EBF
0	埤 9AF5	□	戚 9B56	掠 9B66	□	苜 9BA8	□	玶 9BC8	溶 9BD8	隸 9BE8	颯 9BF8	穠 9C49	□	玦 9C69	□	□
1	□	歲 9B47	咏 9B57	擗 9B67	琦 9B77	□	浔 9BB9	勘 9BC9	瓊 9BD9	□	□	□	□	□	蓀 9C7A	蛄 9CAC
2	夔 9AF7	嶠 9B48	□	擻 9B68	□	□	熯 9BBA	□	□	□	繆 9BFA	睭 9C4B	葳 9C5B	□	□	琣 9CAD
3	叒 9AF8	□	搥 9B59	攜 9B69	棗 9B79	瀟 9BAB	變 9BBB	齧 9BCB	砌 9BDB	杞 9BEB	皦 9BFB	晒 9C4C	□	灑 9C6C	□	□
4	婉 9AF9	□	□	敎 9B6A	檣 9B7A	鋹 9BAC	□	啞 9BCC	砧 9BDC	□	□	愆 9C4D	□	□	耘 9C7D	□
5	嫁 9AFA	羿 9B4B	拒 9B5B	夔 9B6B	□	熙 9BAD	掉 9BBD	□	芷 9BDD	齏 9BED	玃 9BFD	□	魄 9C5E	舩 9C6E	□	蟠 9CB0
6	□	□	□	馘 9B6C	衛 9B7C	爇 9BAE	□	瘠 9BCE	□	□	猜 9BFE	粽 9C4F	膳 9C5F	□	□	嗣 9CB1
7	□	□	搥 9B5D	鑿 9B6D	□	灤 9BAF	玃 9BBF	睨 9BCF	□	鈺 9BEF	□	□	翊 9C60	暉 9C70	衡 9CA2	□
8	婿 9AFD	睿 9B4E	□	矚 9B6E	□	燦 9BB0	蘗 9BC0	剗 9BD0	碛 9BE0	璋 9BF0	玳 9C41	□	滕 9C61	兕 9C71	蕞 9CA3	□
9	琿 9AFE	鸞 9B4F	□	枕 9B6F	□	煠 9BB1	驢 9BC1	□	祉 9BE1	箒 9BF1	□	晉 9C52	□	□	𪗇 9CA4	懂 9CB4
A	糗 9B40	粥 9B50	揲 9B60	□	殷 9BA2	瑤 9BB2	□	屨 9BD2	璋 9BE2	箒 9BF2	玳 9C43	□	驪 9C63	舩 9C73	□	廷 9CB5
B	窳 9B41	悒 9B51	□	□	祐 9BA3	涇 9BB3	絲 9BC3	□	□	咖 9BF3	嫫 9C44	□	□	苻 9C74	蚶 9CA6	媼 9CB6
C	启 9B42	慤 9B52	掘 9B62	□	紘 9BA4	□	□	□	磻 9BE4	□	□	爲 9C55	霆 9C65	□	蛎 9CA7	□
D	冢 9B43	愴 9B53	揆 9B63	詭 9B73	漆 9BA5	灑 9BB5	鑄 9BC5	□	礮 9BE5	□	瓊 9C46	舐 9C56	叩 9C66	楸 9C76	□	璨 9CB8
E	屈 9B44	□	篋 9B64	櫟 9B74	淚 9BA6	□	□	瞽 9BD6	毬 9BE6	□	翮 9C47	□	曷 9C67	□	黼 9CA9	嫿 9CB9
F	嶮 9B45	慇 9B55	揠 9B65	樹 9B75	衡 9BA7	嶂 9BB7	獄 9BC7	矾 9BD7	珣 9BE7	縹 9BF7	淺 9C48	珏 9C58	□	茫 9C78	蚶 9CAA	□

	EC0	EC1	EC2	EC3	EC4	EC5	EC6	EC7	EC8	EC9	ECA	ECB	ECC	ECD	ECE	ECF	
0	<input type="checkbox"/>	塋 9CCB	踰 9CDB	<input type="checkbox"/>	躡 9CFB	<input type="checkbox"/>	霏 9D5C	飶 9D6C	呷 9D7C	<input type="checkbox"/>	嘒 9DBE	<input type="checkbox"/>	<input type="checkbox"/>	<input type="checkbox"/>	捺 9DFE	扞 9E4F	
1	<input type="checkbox"/>	<input type="checkbox"/>	<input type="checkbox"/>	鑷 9CEC	躡 9CFC	<input type="checkbox"/>	<input type="checkbox"/>	髻 9D6D	<input type="checkbox"/>	媯 9DAF	<input type="checkbox"/>	<input type="checkbox"/>	<input type="checkbox"/>	<input type="checkbox"/>	喙 9E40	<input type="checkbox"/>	
2	<input type="checkbox"/>	<input type="checkbox"/>	麟 9CDD	踰 9CED	睿 9CFD	銃 9D4E	璽 9D5E	魴 9D6E	<input type="checkbox"/>	踉 9DB0	<input type="checkbox"/>	<input type="checkbox"/>	<input type="checkbox"/>	<input type="checkbox"/>	<input type="checkbox"/>	<input type="checkbox"/>	攪 9E51
3	<input type="checkbox"/>	訝 9CCE	<input type="checkbox"/>	<input type="checkbox"/>	躡 9CFE	<input type="checkbox"/>	璽 9D5F	魴 9D6F	<input type="checkbox"/>	鎬 9DB1	漪 9DC1	<input type="checkbox"/>	<input type="checkbox"/>	<input type="checkbox"/>	<input type="checkbox"/>	<input type="checkbox"/>	<input type="checkbox"/>
4	<input type="checkbox"/>	霽 9CCF	較 9CDF	<input type="checkbox"/>	躡 9D40	錄 9D50	<input type="checkbox"/>	<input type="checkbox"/>	械 9DA2	鑛 9DB2	番 9DC2	粼 9DD2	<input type="checkbox"/>	粒 9DF2	<input type="checkbox"/>	<input type="checkbox"/>	<input type="checkbox"/>
5	賦 9CC0	<input type="checkbox"/>	<input type="checkbox"/>	鈞 9CF0	躡 9D41	<input type="checkbox"/>	<input type="checkbox"/>	鯁 9D71	<input type="checkbox"/>	深 9DB3	<input type="checkbox"/>	<input type="checkbox"/>	<input type="checkbox"/>	<input type="checkbox"/>	嚙 9E44	咭 9E54	
6	馭 9CC1	<input type="checkbox"/>	蒨 9CE1	<input type="checkbox"/>	躡 9D42	鎬 9D52	<input type="checkbox"/>	魴 9D72	璿 9DA4	胤 9DB4	<input type="checkbox"/>	湜 9DD4	<input type="checkbox"/>	<input type="checkbox"/>	<input type="checkbox"/>	<input type="checkbox"/>	<input type="checkbox"/>
7	<input type="checkbox"/>	醴 9CD2	<input type="checkbox"/>	琿 9CF2	軫 9D43	鏗 9D53	頤 9D63	<input type="checkbox"/>	<input type="checkbox"/>	<input type="checkbox"/>	娥 9DC5	<input type="checkbox"/>	<input type="checkbox"/>	<input type="checkbox"/>	<input type="checkbox"/>	<input type="checkbox"/>	<input type="checkbox"/>
8	襪 9CC3	翎 9CD3	<input type="checkbox"/>	<input type="checkbox"/>	輶 9D44	壘 9D54	颯 9D64	<input type="checkbox"/>	<input type="checkbox"/>	袜 9DB6	媚 9DC6	<input type="checkbox"/>	<input type="checkbox"/>	<input type="checkbox"/>	<input type="checkbox"/>	<input type="checkbox"/>	<input type="checkbox"/>
9	親 9CC4	諱 9CD4	<input type="checkbox"/>	<input type="checkbox"/>	輶 9D45	<input type="checkbox"/>	颯 9D65	慶 9D75	<input type="checkbox"/>	洵 9DB7	<input type="checkbox"/>	噴 9DD7	<input type="checkbox"/>	<input type="checkbox"/>	<input type="checkbox"/>	<input type="checkbox"/>	<input type="checkbox"/>
A	<input type="checkbox"/>	詬 9CD5	躡 9CE5	<input type="checkbox"/>	<input type="checkbox"/>	斲 9D56	颯 9D66	<input type="checkbox"/>	<input type="checkbox"/>	袒 9DB8	<input type="checkbox"/>	吮 9DD8	<input type="checkbox"/>	<input type="checkbox"/>	<input type="checkbox"/>	<input type="checkbox"/>	<input type="checkbox"/>
B	<input type="checkbox"/>	譏 9CD6	踰 9CE6	瑋 9CF6	迫 9D47	<input type="checkbox"/>	餽 9D67	赴 9D77	<input type="checkbox"/>	窖 9DB9	箬 9DC9	樁 9DD9	<input type="checkbox"/>	叵 9DF9	<input type="checkbox"/>	<input type="checkbox"/>	<input type="checkbox"/>
C	奮 9CC7	眈 9CD7	驤 9CE7	淇 9CF7	邨 9D48	雒 9D58	駢 9D68	<input type="checkbox"/>	<input type="checkbox"/>	<input type="checkbox"/>	<input type="checkbox"/>	<input type="checkbox"/>	<input type="checkbox"/>	<input type="checkbox"/>	叻 9DFA	<input type="checkbox"/>	曝 9ESB
D	<input type="checkbox"/>	濫 9CD8	塹 9CE8	<input type="checkbox"/>	<input type="checkbox"/>	霽 9D59	駢 9D69	<input type="checkbox"/>	鎬 9DAB	粧 9DBB	睿 9DCB	<input type="checkbox"/>	<input type="checkbox"/>	<input type="checkbox"/>	<input type="checkbox"/>	<input type="checkbox"/>	<input type="checkbox"/>
E	檣 9CC9	<input type="checkbox"/>	翳 9CE9	<input type="checkbox"/>	<input type="checkbox"/>	<input type="checkbox"/>	驥 9D6A	齋 9D7A	颯 9DAC	罇 9DBC	<input type="checkbox"/>	<input type="checkbox"/>	<input type="checkbox"/>	<input type="checkbox"/>	叻 9DFC	<input type="checkbox"/>	<input type="checkbox"/>
F	躡 9CCA	<input type="checkbox"/>	躡 9CEA	踰 9CFA	叢 9D4B	霽 9D5B	驪 9D6B	<input type="checkbox"/>	<input type="checkbox"/>	<input type="checkbox"/>	<input type="checkbox"/>	魴 9DCD	<input type="checkbox"/>	略 9DED	呷 9DFD	<input type="checkbox"/>	<input type="checkbox"/>

	ED0	ED1	ED2	ED3	ED4	ED5	ED6	ED7	ED8	ED9	EDA	EDB	EDC	EDD	EDE	EDF	
0	<input type="checkbox"/>	焯 9E6F	<input type="checkbox"/>	<input type="checkbox"/>	<input type="checkbox"/>	<input type="checkbox"/>	<input type="checkbox"/>	<input type="checkbox"/>	<input type="checkbox"/>	<input type="checkbox"/>	<input type="checkbox"/>	<input type="checkbox"/>	<input type="checkbox"/>	<input type="checkbox"/>	<input type="checkbox"/>	<input type="checkbox"/>	
1	<input type="checkbox"/>	蝮 9E70	<input type="checkbox"/>	<input type="checkbox"/>	鏻 9EC2	深 9ED2	<input type="checkbox"/>	航 9EF2	姪 9F43	炭 9F53	<input type="checkbox"/>	<input type="checkbox"/>	<input type="checkbox"/>	蕞 9FB5	哏 9FC5	<input type="checkbox"/>	
2	<input type="checkbox"/>	<input type="checkbox"/>	擗 9EA3	<input type="checkbox"/>	鷗 9EC3	蛭 9ED3	啞 9EE3	熿 9EF3	<input type="checkbox"/>	<input type="checkbox"/>	<input type="checkbox"/>	<input type="checkbox"/>	<input type="checkbox"/>	<input type="checkbox"/>	<input type="checkbox"/>	<input type="checkbox"/>	<input type="checkbox"/>
3	<input type="checkbox"/>	囧 9E72	<input type="checkbox"/>	<input type="checkbox"/>	<input type="checkbox"/>	脍 9ED4	<input type="checkbox"/>	<input type="checkbox"/>	<input type="checkbox"/>	<input type="checkbox"/>	<input type="checkbox"/>	<input type="checkbox"/>	<input type="checkbox"/>	<input type="checkbox"/>	<input type="checkbox"/>	<input type="checkbox"/>	
4	嘯 9E63	<input type="checkbox"/>	狷 9EA5	<input type="checkbox"/>	<input type="checkbox"/>	樾 9ED5	<input type="checkbox"/>	<input type="checkbox"/>	頰 9F46	<input type="checkbox"/>	<input type="checkbox"/>	<input type="checkbox"/>	<input type="checkbox"/>	<input type="checkbox"/>	<input type="checkbox"/>	<input type="checkbox"/>	
5	<input type="checkbox"/>	深 9E74	鮫 9EA6	<input type="checkbox"/>	彙 9EC6	<input type="checkbox"/>	<input type="checkbox"/>	垤 9EF6	囂 9F47	<input type="checkbox"/>	<input type="checkbox"/>	<input type="checkbox"/>	<input type="checkbox"/>	<input type="checkbox"/>	<input type="checkbox"/>	<input type="checkbox"/>	
6	<input type="checkbox"/>	嚙 9E75	嚙 9EA7	<input type="checkbox"/>	<input type="checkbox"/>	<input type="checkbox"/>	<input type="checkbox"/>	<input type="checkbox"/>	贛 9F48	<input type="checkbox"/>	玨 9F68	<input type="checkbox"/>	娟 9FAA	<input type="checkbox"/>	<input type="checkbox"/>	<input type="checkbox"/>	
7	攏 9E66	呖 9E76	啗 9EA8	<input type="checkbox"/>	鮓 9EC8	澍 9ED8	<input type="checkbox"/>	琬 9EF8	<input type="checkbox"/>	<input type="checkbox"/>	<input type="checkbox"/>	<input type="checkbox"/>	<input type="checkbox"/>	儗 9FBB	<input type="checkbox"/>	<input type="checkbox"/>	
8	<input type="checkbox"/>	啖 9E77	<input type="checkbox"/>	<input type="checkbox"/>	<input type="checkbox"/>	沼 9ED9	<input type="checkbox"/>	鮓 9EF9	唁 9F4A	<input type="checkbox"/>	<input type="checkbox"/>	<input type="checkbox"/>	<input type="checkbox"/>	<input type="checkbox"/>	<input type="checkbox"/>	<input type="checkbox"/>	
9	<input type="checkbox"/>	<input type="checkbox"/>	蠶 9EAA	<input type="checkbox"/>	<input type="checkbox"/>	<input type="checkbox"/>	<input type="checkbox"/>	<input type="checkbox"/>	蒹 9F4B	<input type="checkbox"/>	<input type="checkbox"/>	<input type="checkbox"/>	<input type="checkbox"/>	<input type="checkbox"/>	<input type="checkbox"/>	<input type="checkbox"/>	
A	臙 9E69	厝 9E79	峭 9EAB	<input type="checkbox"/>	泰 9ECB	<input type="checkbox"/>	<input type="checkbox"/>	靜 9EFB	璦 9F4C	<input type="checkbox"/>	<input type="checkbox"/>	<input type="checkbox"/>	<input type="checkbox"/>	箴 9FBE	<input type="checkbox"/>	<input type="checkbox"/>	
B	<input type="checkbox"/>	<input type="checkbox"/>	<input type="checkbox"/>	扣 9EBC	鮓 9ECC	<input type="checkbox"/>	黠 9EEC	<input type="checkbox"/>	啖 9F4D	<input type="checkbox"/>	<input type="checkbox"/>	<input type="checkbox"/>	<input type="checkbox"/>	泐 9FBF	<input type="checkbox"/>	<input type="checkbox"/>	
C	慄 9E6B	醜 9E7B	綰 9EAD	<input type="checkbox"/>	<input type="checkbox"/>	<input type="checkbox"/>	<input type="checkbox"/>	<input type="checkbox"/>	<input type="checkbox"/>	<input type="checkbox"/>	<input type="checkbox"/>	<input type="checkbox"/>	<input type="checkbox"/>	<input type="checkbox"/>	<input type="checkbox"/>	<input type="checkbox"/>	
D	貯 9E6C	跽 9E7C	躡 9EAE	甄 9EBE	冪 9ECE	<input type="checkbox"/>	<input type="checkbox"/>	<input type="checkbox"/>	<input type="checkbox"/>	<input type="checkbox"/>	<input type="checkbox"/>	<input type="checkbox"/>	<input type="checkbox"/>	𪗇 9FC1	伏 9FD1	<input type="checkbox"/>	
E	焮 9E6D	嗜 9E7D	<input type="checkbox"/>	<input type="checkbox"/>	颯 9ECF	<input type="checkbox"/>	<input type="checkbox"/>	<input type="checkbox"/>	嶠 9F50	<input type="checkbox"/>	<input type="checkbox"/>	<input type="checkbox"/>	<input type="checkbox"/>	<input type="checkbox"/>	<input type="checkbox"/>	<input type="checkbox"/>	
F	貼 9E6E	<input type="checkbox"/>	<input type="checkbox"/>	<input type="checkbox"/>	鴿 9ED0	鳧 9EE0	<input type="checkbox"/>	<input type="checkbox"/>	<input type="checkbox"/>	<input type="checkbox"/>	<input type="checkbox"/>	<input type="checkbox"/>	<input type="checkbox"/>	陡 9FB3	<input type="checkbox"/>	<input type="checkbox"/>	

	EE0	EE1	EE2	EE3	EE4	EE5	EE6	EE7	EE8	EE9	EEA	EEB	EEC	EED	EEE	EEF
0	<input type="checkbox"/>	<input type="checkbox"/>	𪛗 A045	媯 A055	<input type="checkbox"/>	<input type="checkbox"/>	岷 A0A7	<input type="checkbox"/>	<input type="checkbox"/>	<input type="checkbox"/>	<input type="checkbox"/>	臙 A0F7				
1	<input type="checkbox"/>	𪛘 9FF5	<input type="checkbox"/>	𪛙 A056	<input type="checkbox"/>	<input type="checkbox"/>	<input type="checkbox"/>	<input type="checkbox"/>	<input type="checkbox"/>	漚 A0D8	𪛚 A0E8	𪛛 A0F8				
2	<input type="checkbox"/>	<input type="checkbox"/>	𪛜 A047	<input type="checkbox"/>	<input type="checkbox"/>	<input type="checkbox"/>	<input type="checkbox"/>	<input type="checkbox"/>	<input type="checkbox"/>	<input type="checkbox"/>	𪛞 A0E9	<input type="checkbox"/>				
3	<input type="checkbox"/>	<input type="checkbox"/>	<input type="checkbox"/>	<input type="checkbox"/>	<input type="checkbox"/>	<input type="checkbox"/>	<input type="checkbox"/>	<input type="checkbox"/>	<input type="checkbox"/>	<input type="checkbox"/>	𪛟 A0EA	<input type="checkbox"/>				
4	<input type="checkbox"/>	<input type="checkbox"/>	<input type="checkbox"/>	𪛡 A059	<input type="checkbox"/>	<input type="checkbox"/>	𪛢 A0AB	<input type="checkbox"/>	<input type="checkbox"/>	<input type="checkbox"/>	𪛣 A0EB	𪛤 A0FB				
5	<input type="checkbox"/>	𪛥 9FF9	<input type="checkbox"/>	<input type="checkbox"/>	<input type="checkbox"/>	<input type="checkbox"/>	<input type="checkbox"/>	<input type="checkbox"/>	<input type="checkbox"/>	<input type="checkbox"/>	𪛧 A0EC	<input type="checkbox"/>				
6	<input type="checkbox"/>	<input type="checkbox"/>	<input type="checkbox"/>	<input type="checkbox"/>	<input type="checkbox"/>	𪛩 A07B	<input type="checkbox"/>	𪛪 A0BD	<input type="checkbox"/>	<input type="checkbox"/>	𪛫 A0ED	<input type="checkbox"/>				
7	<input type="checkbox"/>	<input type="checkbox"/>	<input type="checkbox"/>	<input type="checkbox"/>	<input type="checkbox"/>	<input type="checkbox"/>	<input type="checkbox"/>	<input type="checkbox"/>	<input type="checkbox"/>	<input type="checkbox"/>	𪛭 A0EE	𪛮 A0FE				
8	𪛰 9FEC	<input type="checkbox"/>	<input type="checkbox"/>	<input type="checkbox"/>	𪛲 A06D	<input type="checkbox"/>	<input type="checkbox"/>	<input type="checkbox"/>	<input type="checkbox"/>	<input type="checkbox"/>	𪛴 A0EF					
9	<input type="checkbox"/>	<input type="checkbox"/>	<input type="checkbox"/>	<input type="checkbox"/>	<input type="checkbox"/>	<input type="checkbox"/>	<input type="checkbox"/>	<input type="checkbox"/>	<input type="checkbox"/>	<input type="checkbox"/>	𪛶 A0F0					
A	<input type="checkbox"/>	<input type="checkbox"/>	𪛸 A04F	<input type="checkbox"/>	<input type="checkbox"/>	<input type="checkbox"/>	𪛺 A0B1	<input type="checkbox"/>	<input type="checkbox"/>	<input type="checkbox"/>	𪛻 A0F1					
B	<input type="checkbox"/>	𪛼 A040	<input type="checkbox"/>	<input type="checkbox"/>	<input type="checkbox"/>	𪛾 A0A2	<input type="checkbox"/>	<input type="checkbox"/>	<input type="checkbox"/>	<input type="checkbox"/>	<input type="checkbox"/>					
C	<input type="checkbox"/>	<input type="checkbox"/>	<input type="checkbox"/>	<input type="checkbox"/>	<input type="checkbox"/>	<input type="checkbox"/>	<input type="checkbox"/>	𪛿 A0C3	<input type="checkbox"/>	𪛽 A0E3	𪛾 A0F3					
D	<input type="checkbox"/>	<input type="checkbox"/>	<input type="checkbox"/>	<input type="checkbox"/>	<input type="checkbox"/>	𪛿 A0A4	<input type="checkbox"/>	<input type="checkbox"/>	<input type="checkbox"/>	<input type="checkbox"/>	𪛿 A0F4					
E	<input type="checkbox"/>	<input type="checkbox"/>	<input type="checkbox"/>	<input type="checkbox"/>	<input type="checkbox"/>	<input type="checkbox"/>	<input type="checkbox"/>	𪛿 A0C5	<input type="checkbox"/>	<input type="checkbox"/>	𪛿 A0F5					
F	<input type="checkbox"/>	<input type="checkbox"/>	<input type="checkbox"/>	<input type="checkbox"/>	<input type="checkbox"/>	<input type="checkbox"/>	<input type="checkbox"/>	<input type="checkbox"/>	<input type="checkbox"/>	<input type="checkbox"/>	𪛿 A0F6					

	EF0	EF1	EF2	EF3	EF4	EF5	EF6	EF7	EF8	EF9	EFA	EFB	EFC	EFD	EFE	EFF
0																
1																
2																
3																
4																
5																
6																
7																
8																
9																
A																
B																
C																
D																
E																
F																

	F00	F01	F02	F03	F04	F05	F06	F07	F08	F09	F0A	F0B	F0C	F0D	F0E	F0F
0																
1																
2																
3																
4																
5																
6																
7																
8																
9																
A																
B																
C																
D																
E																
F																

	F10	F11	F12	F13	F14	F15	F16	F17	F18	F19	F1A	F1B	F1C	F1D	F1E	F1F
0																
1																
2																
3																
4																
5																
6																
7																
8																
9																
A																
B																
C																
D																
E																
F																







	F20	F21	F22	F23	F24	F25	F26	F27	F28	F29	F2A	F2B	F2C	F2D	F2E	F2F
0																
1																
2																
3																
4																
5																
6																
7																
8																
9																
A																
B																
C																
D																
E																
F																

	F30	F31	F32	F33	F34	F35	F36	F37	F38	F39	F3A	F3B	F3C	F3D	F3E	F3F
0		𠃓 884D	<input type="checkbox"/>	<input type="checkbox"/>	<input type="checkbox"/>						𠃓 8940	<input type="checkbox"/>	<input type="checkbox"/>	<input type="checkbox"/>	<input type="checkbox"/>	𠃓 89B2
1		𠃔 884E	<input type="checkbox"/>	<input type="checkbox"/>	<input type="checkbox"/>						𠃔 8941	<input type="checkbox"/>	<input type="checkbox"/>	<input type="checkbox"/>	<input type="checkbox"/>	
2		𠃕 884F	<input type="checkbox"/>	<input type="checkbox"/>	<input type="checkbox"/>							<input type="checkbox"/>	<input type="checkbox"/>	<input type="checkbox"/>	<input type="checkbox"/>	
3	𠃖 8840	𠃗 8850	<input type="checkbox"/>	<input type="checkbox"/>	<input type="checkbox"/>						<input type="checkbox"/>	<input type="checkbox"/>	<input type="checkbox"/>	<input type="checkbox"/>	<input type="checkbox"/>	<input type="checkbox"/>
4	𠃘 8841	𠃙 8851	<input type="checkbox"/>	<input type="checkbox"/>	ē 88A3							<input type="checkbox"/>	<input type="checkbox"/>	<input type="checkbox"/>	<input type="checkbox"/>	<input type="checkbox"/>
5	𠃚 8842	𠃛 8852	ē 8862	<input type="checkbox"/>	<input type="checkbox"/>							<input type="checkbox"/>	<input type="checkbox"/>	<input type="checkbox"/>		<input type="checkbox"/>
6	𠃜 8843	𠃝 8853	<input type="checkbox"/>	<input type="checkbox"/>	ě 88A5						<input type="checkbox"/>	<input type="checkbox"/>	<input type="checkbox"/>	<input type="checkbox"/>		<input type="checkbox"/>
7	𠃞 8844	𠃟 8854	ě 8864	<input type="checkbox"/>	<input type="checkbox"/>						<input type="checkbox"/>	<input type="checkbox"/>	<input type="checkbox"/>	<input type="checkbox"/>		<input type="checkbox"/>
8	𠃠 8845	𠃡 8855	<input type="checkbox"/>	<input type="checkbox"/>	<input type="checkbox"/>						<input type="checkbox"/>	<input type="checkbox"/>	<input type="checkbox"/>	<input type="checkbox"/>		<input type="checkbox"/>
9	𠃣 8846	<input type="checkbox"/>	<input type="checkbox"/>	<input type="checkbox"/>	<input type="checkbox"/>						<input type="checkbox"/>	<input type="checkbox"/>	<input type="checkbox"/>	<input type="checkbox"/>	<input type="checkbox"/>	𠃣 89BB
A	𠃥 8847	<input type="checkbox"/>	<input type="checkbox"/>	<input type="checkbox"/>	≡ 88A9							<input type="checkbox"/>	<input type="checkbox"/>	<input type="checkbox"/>	<input type="checkbox"/>	𠃥 89BC
B	𠃧 8848	<input type="checkbox"/>	<input type="checkbox"/>	<input type="checkbox"/>	⊖ 88AA							<input type="checkbox"/>	<input type="checkbox"/>	<input type="checkbox"/>	<input type="checkbox"/>	<input type="checkbox"/>
C	𠃩 8849	<input type="checkbox"/>	<input type="checkbox"/>	<input type="checkbox"/>							𠃩 894C	<input type="checkbox"/>	<input type="checkbox"/>	<input type="checkbox"/>	<input type="checkbox"/>	𠃩 89BE
D	𠃫 884A	<input type="checkbox"/>	<input type="checkbox"/>	<input type="checkbox"/>							<input type="checkbox"/>	<input type="checkbox"/>	<input type="checkbox"/>	<input type="checkbox"/>		<input type="checkbox"/>
E	𠃭 884B	<input type="checkbox"/>	<input type="checkbox"/>	<input type="checkbox"/>							<input type="checkbox"/>	<input type="checkbox"/>	<input type="checkbox"/>	<input type="checkbox"/>		
F	𠃯 884C	<input type="checkbox"/>	<input type="checkbox"/>	<input type="checkbox"/>							<input type="checkbox"/>	<input type="checkbox"/>	<input type="checkbox"/>	<input type="checkbox"/>		<input type="checkbox"/>

	F40	F41	F42	F43	F44	F45	F46	F47	F48	F49	F4A	F4B	F4C	F4D	F4E	F4F
0					𠵼 8A43	躑 8A53			𠵼 8AA5	嚙 8AB5		𠵼 8AD5	𠵼 8AE5		揜 8B46	
1					𠵼 8A44	𠵼 8A54	𠵼 8A64		𠵼 8AA6	𠵼 8AB6			𠵼 8AE6	𠵼 8AF6		
2					𠵼 8A45	𠵼 8A55	𠵼 8A65					𠵼 8AD7		𠵼 8AF7	𠵼 8B48	𠵼 8B58
3							𠵼 8A66		𠵼 8AA8			𠵼 8AD8	𠵼 8AE8	𠵼 8AF8	𠵼 8B49	𠵼 8B59
4					𠵼 8A47	𠵼 8A57		𠵼 8A77	𠵼 8AA9		𠵼 8AC9	𠵼 8AD9	𠵼 8AE9	𠵼 8AF9	𠵼 8B4A	
5						𠵼 8A58	𠵼 8A68		𠵼 8AAA		𠵼 8ACA		𠵼 8AEA	𠵼 8AFA	𠵼 8B4B	
6					𠵼 8A49	𠵼 8A59	𠵼 8A69				𠵼 8ACB				𠵼 8B4C	
7						𠵼 8A5A		𠵼 8A7A		𠵼 8ABC	𠵼 8ACC	𠵼 8ADC	𠵼 8AEC	𠵼 8AFC	𠵼 8B4D	
8	𠵼 89CA				𠵼 8A4B			𠵼 8A7B	𠵼 8AAD	𠵼 8ABD			𠵼 8AED		𠵼 8B4E	𠵼 8B5E
9	𠵼 89CB				𠵼 8A4C		𠵼 8A6C	𠵼 8A7C			𠵼 8ACE		𠵼 8AEE	𠵼 8AFE	𠵼 8B4F	
A	𠵼 89CC					𠵼 8A5D					𠵼 8ACF	𠵼 8ADF	𠵼 8AEF	𠵼 8B40		
B	𠵼 89CD				𠵼 8A4E	𠵼 8A5E		𠵼 8A7E	𠵼 8AB0	𠵼 8AC0		𠵼 8AE0		𠵼 8B41		
C						𠵼 8A5F	𠵼 8A6F	𠵼 8AA1				𠵼 8AE1	𠵼 8AF1	𠵼 8B42		𠵼 8B62
D				𠵼 8A40	𠵼 8A50	𠵼 8A60	𠵼 8A70	𠵼 8AA2	𠵼 8AB2		𠵼 8AD2	𠵼 8AE2	𠵼 8AF2	𠵼 8B43		
E						𠵼 8A61	𠵼 8A71	𠵼 8AA3	𠵼 8AB3	𠵼 8AC3		𠵼 8AE3	𠵼 8AF3	𠵼 8B44		𠵼 8B64
F						𠵼 8A62	𠵼 8A72		𠵼 8AB4		𠵼 8AD4	𠵼 8AE4	𠵼 8AF4	𠵼 8B45	𠵼 8B55	𠵼 8B65

	F50	F51	F52	F53	F54	F55	F56	F57	F58	F59	F5A	F5B	F5C	F5D	F5E	F5F
0	噉 8B66	癩 8B76	嘸 8BA8	<input type="checkbox"/>	<input type="checkbox"/>	<input type="checkbox"/>	<input type="checkbox"/>	<input type="checkbox"/>								
1	噉 8B67	擲 8B77	睛 8BA9	<input type="checkbox"/>	<input type="checkbox"/>	<input type="checkbox"/>	<input type="checkbox"/>	<input type="checkbox"/>								
2	<input type="checkbox"/>	<input type="checkbox"/>	麪 8BAA	<input type="checkbox"/>	<input type="checkbox"/>	<input type="checkbox"/>	<input type="checkbox"/>	𠂇 8BFA								
3	痢 8B69	噤 8B79	璫 8BAB	筭 8BBB	<input type="checkbox"/>	𠂇 8BDB	<input type="checkbox"/>	<input type="checkbox"/>								
4	<input type="checkbox"/>	噤 8B7A	嫫 8BAC	𠂇 8BBC	<input type="checkbox"/>	<input type="checkbox"/>	<input type="checkbox"/>	<input type="checkbox"/>								
5	噉 8B6B	噉 8B7B	灑 8BAD	<input type="checkbox"/>	<input type="checkbox"/>		𠂇 8BED	<input type="checkbox"/>								
6	<input type="checkbox"/>	噉 8B7C	聽 8BAE	<input type="checkbox"/>	<input type="checkbox"/>	𠂇 8BDE	<input type="checkbox"/>									
7	𠂇 8B6D	<input type="checkbox"/>	<input type="checkbox"/>	<input type="checkbox"/>	<input type="checkbox"/>	<input type="checkbox"/>	<input type="checkbox"/>									
8	噉 8B6E	噉 8B7E	<input type="checkbox"/>	<input type="checkbox"/>	<input type="checkbox"/>	<input type="checkbox"/>	<input type="checkbox"/>									
9	吟 8B6F	桶 8BA1	<input type="checkbox"/>	<input type="checkbox"/>	<input type="checkbox"/>	聿 8BE1	<input type="checkbox"/>									
A	噉 8B70	軌 8BA2	𠂇 8BB2	𠂇 8BC2	<input type="checkbox"/>	𠂇 8BE2	<input type="checkbox"/>									
B	噉 8B71	噉 8BA3	<input type="checkbox"/>	𠂇 8BC3	<input type="checkbox"/>	<input type="checkbox"/>	𠂇 8BF3									
C	噉 8B72	噉 8BA4	<input type="checkbox"/>	<input type="checkbox"/>	<input type="checkbox"/>	<input type="checkbox"/>	<input type="checkbox"/>									
D	躑 8B73	𠂇 8BA5	<input type="checkbox"/>	𠂇 8BC5	<input type="checkbox"/>	<input type="checkbox"/>	<input type="checkbox"/>									
E	𠂇 8B74	<input type="checkbox"/>	<input type="checkbox"/>	<input type="checkbox"/>	𠂇 8BD6	𠂇 8BE6	<input type="checkbox"/>									
F	噉 8B75	噉 8BA7	<input type="checkbox"/>	<input type="checkbox"/>	<input type="checkbox"/>	<input type="checkbox"/>	<input type="checkbox"/>									

	F60	F61	F62	F63	F64	F65	F66	F67	F68	F69	F6A	F6B	F6C	F6D	F6E	F6F
0					<input type="checkbox"/>	<input type="checkbox"/>	<input type="checkbox"/>	<input type="checkbox"/>	<input type="checkbox"/>	<input type="checkbox"/>	<input type="checkbox"/>	喙 8DFE	<input type="checkbox"/>	<input type="checkbox"/>	<input type="checkbox"/>	<input type="checkbox"/>
1					<input type="checkbox"/>	<input type="checkbox"/>	<input type="checkbox"/>	<input type="checkbox"/>	<input type="checkbox"/>	<input type="checkbox"/>	<input type="checkbox"/>	<input type="checkbox"/>	<input type="checkbox"/>	<input type="checkbox"/>	<input type="checkbox"/>	<input type="checkbox"/>
2					<input type="checkbox"/>	<input type="checkbox"/>	<input type="checkbox"/>	<input type="checkbox"/>	<input type="checkbox"/>	<input type="checkbox"/>	<input type="checkbox"/>	<input type="checkbox"/>	<input type="checkbox"/>	<input type="checkbox"/>	<input type="checkbox"/>	<input type="checkbox"/>
3					<input type="checkbox"/>	<input type="checkbox"/>	<input type="checkbox"/>	<input type="checkbox"/>	<input type="checkbox"/>	<input type="checkbox"/>	<input type="checkbox"/>	<input type="checkbox"/>	<input type="checkbox"/>	<input type="checkbox"/>		<input type="checkbox"/>
4				<input type="checkbox"/>	<input type="checkbox"/>	<input type="checkbox"/>	<input type="checkbox"/>	<input type="checkbox"/>	<input type="checkbox"/>	鉗 8DE2	<input type="checkbox"/>	<input type="checkbox"/>	<input type="checkbox"/>	<input type="checkbox"/>	<input type="checkbox"/>	<input type="checkbox"/>
5				<input type="checkbox"/>	<input type="checkbox"/>	<input type="checkbox"/>	<input type="checkbox"/>	<input type="checkbox"/>	<input type="checkbox"/>	<input type="checkbox"/>	<input type="checkbox"/>	<input type="checkbox"/>	<input type="checkbox"/>	<input type="checkbox"/>		<input type="checkbox"/>
6				<input type="checkbox"/>	<input type="checkbox"/>	<input type="checkbox"/>	<input type="checkbox"/>	<input type="checkbox"/>	<input type="checkbox"/>	<input type="checkbox"/>	<input type="checkbox"/>	<input type="checkbox"/>	<input type="checkbox"/>	<input type="checkbox"/>	<input type="checkbox"/>	<input type="checkbox"/>
7				<input type="checkbox"/>	<input type="checkbox"/>	<input type="checkbox"/>	<input type="checkbox"/>	<input type="checkbox"/>	<input type="checkbox"/>	<input type="checkbox"/>	<input type="checkbox"/>	<input type="checkbox"/>	<input type="checkbox"/>	<input type="checkbox"/>		<input type="checkbox"/>
8				<input type="checkbox"/>	<input type="checkbox"/>	<input type="checkbox"/>	<input type="checkbox"/>	<input type="checkbox"/>	<input type="checkbox"/>	<input type="checkbox"/>	<input type="checkbox"/>	<input type="checkbox"/>	<input type="checkbox"/>	<input type="checkbox"/>	<input type="checkbox"/>	<input type="checkbox"/>
9				<input type="checkbox"/>	<input type="checkbox"/>	<input type="checkbox"/>	<input type="checkbox"/>	<input type="checkbox"/>	<input type="checkbox"/>	<input type="checkbox"/>	<input type="checkbox"/>	<input type="checkbox"/>	<input type="checkbox"/>	<input type="checkbox"/>	<input type="checkbox"/>	<input type="checkbox"/>
A				<input type="checkbox"/>	<input type="checkbox"/>	<input type="checkbox"/>	<input type="checkbox"/>	<input type="checkbox"/>	<input type="checkbox"/>	<input type="checkbox"/>	<input type="checkbox"/>	<input type="checkbox"/>	<input type="checkbox"/>	<input type="checkbox"/>	<input type="checkbox"/>	<input type="checkbox"/>
B				<input type="checkbox"/>	<input type="checkbox"/>	<input type="checkbox"/>	<input type="checkbox"/>	<input type="checkbox"/>	<input type="checkbox"/>	<input type="checkbox"/>	<input type="checkbox"/>	<input type="checkbox"/>	<input type="checkbox"/>	<input type="checkbox"/>	<input type="checkbox"/>	<input type="checkbox"/>
C				<input type="checkbox"/>	<input type="checkbox"/>	<input type="checkbox"/>	<input type="checkbox"/>	<input type="checkbox"/>	<input type="checkbox"/>	<input type="checkbox"/>	<input type="checkbox"/>	<input type="checkbox"/>	<input type="checkbox"/>	<input type="checkbox"/>	<input type="checkbox"/>	<input type="checkbox"/>
D				<input type="checkbox"/>	<input type="checkbox"/>	<input type="checkbox"/>	<input type="checkbox"/>	<input type="checkbox"/>	<input type="checkbox"/>	<input type="checkbox"/>	偽 8DFB	<input type="checkbox"/>	<input type="checkbox"/>	<input type="checkbox"/>	<input type="checkbox"/>	<input type="checkbox"/>
E				<input type="checkbox"/>	<input type="checkbox"/>	<input type="checkbox"/>	<input type="checkbox"/>	<input type="checkbox"/>	<input type="checkbox"/>	濼 8DEC	<input type="checkbox"/>	<input type="checkbox"/>	<input type="checkbox"/>	<input type="checkbox"/>		<input type="checkbox"/>
F				<input type="checkbox"/>	<input type="checkbox"/>	<input type="checkbox"/>	<input type="checkbox"/>	<input type="checkbox"/>	<input type="checkbox"/>	<input type="checkbox"/>	<input type="checkbox"/>	<input type="checkbox"/>	<input type="checkbox"/>			<input type="checkbox"/>

	F70	F71	F72	F73	F74	F75	F76	F77	F78	F79	F7A	F7B	F7C	F7D	F7E	F7F
0	<input type="checkbox"/>	<input type="checkbox"/>	<input type="checkbox"/>	<input type="checkbox"/>	<input type="checkbox"/>	<input type="checkbox"/>	<input type="checkbox"/>	<input type="checkbox"/>	<input type="checkbox"/>	<input type="checkbox"/>	<input type="checkbox"/>	<input type="checkbox"/>	<input type="checkbox"/>	<input type="checkbox"/>	<input type="checkbox"/>	
1	<input type="checkbox"/>	<input type="checkbox"/>	<input type="checkbox"/>	<input type="checkbox"/>	<input type="checkbox"/>	<input type="checkbox"/>	<input type="checkbox"/>	<input type="checkbox"/>	<input type="checkbox"/>	<input type="checkbox"/>	<input type="checkbox"/>	<input type="checkbox"/>	<input type="checkbox"/>	<input type="checkbox"/>	<input type="checkbox"/>	
2	<input type="checkbox"/>	<input type="checkbox"/>	<input type="checkbox"/>	<input type="checkbox"/>	<input type="checkbox"/>	<input type="checkbox"/>	<input type="checkbox"/>	<input type="checkbox"/>	<input type="checkbox"/>	<input type="checkbox"/>	<input type="checkbox"/>	<input type="checkbox"/>	<input type="checkbox"/>	<input type="checkbox"/>	<input type="checkbox"/>	
3	<input type="checkbox"/>	<input type="checkbox"/>	<input type="checkbox"/>	<input type="checkbox"/>	<input type="checkbox"/>	<input type="checkbox"/>	<input type="checkbox"/>	<input type="checkbox"/>	<input type="checkbox"/>	<input type="checkbox"/>	<input type="checkbox"/>	<input type="checkbox"/>	<input type="checkbox"/>	<input type="checkbox"/>	<input type="checkbox"/>	
4	<input type="checkbox"/>	<input type="checkbox"/>	<input type="checkbox"/>	<input type="checkbox"/>	<input type="checkbox"/>	<input type="checkbox"/>	<input type="checkbox"/>	<input type="checkbox"/>	<input type="checkbox"/>	<input type="checkbox"/>	<input type="checkbox"/>	<input type="checkbox"/>	<input type="checkbox"/>	<input type="checkbox"/>	<input type="checkbox"/>	
5	<input type="checkbox"/>	<input type="checkbox"/>	<input type="checkbox"/>	<input type="checkbox"/>	<input type="checkbox"/>	<input type="checkbox"/>	<input type="checkbox"/>	<input type="checkbox"/>	<input type="checkbox"/>	<input type="checkbox"/>	<input type="checkbox"/>	<input type="checkbox"/>	<input type="checkbox"/>	<input type="checkbox"/>		
6	<input type="checkbox"/>	<input type="checkbox"/>	<input type="checkbox"/>	<input type="checkbox"/>	<input type="checkbox"/>	<input type="checkbox"/>	<input type="checkbox"/>	<input type="checkbox"/>	<input type="checkbox"/>	<input type="checkbox"/>	<input type="checkbox"/>	<input type="checkbox"/>	<input type="checkbox"/>	<input type="checkbox"/>		
7	<input type="checkbox"/>	<input type="checkbox"/>	<input type="checkbox"/>	<input type="checkbox"/>	<input type="checkbox"/>	<input type="checkbox"/>	<input type="checkbox"/>	<input type="checkbox"/>	<input type="checkbox"/>	<input type="checkbox"/>	<input type="checkbox"/>	<input type="checkbox"/>	<input type="checkbox"/>	<input type="checkbox"/>	<input type="checkbox"/>	
8	<input type="checkbox"/>	<input type="checkbox"/>	<input type="checkbox"/>	<input type="checkbox"/>	<input type="checkbox"/>	<input type="checkbox"/>	<input type="checkbox"/>	<input type="checkbox"/>	<input type="checkbox"/>	<input type="checkbox"/>	<input type="checkbox"/>	<input type="checkbox"/>	<input type="checkbox"/>	<input type="checkbox"/>		
9	<input type="checkbox"/>	<input type="checkbox"/>	<input type="checkbox"/>	<input type="checkbox"/>	<input type="checkbox"/>	<input type="checkbox"/>	<input type="checkbox"/>	<input type="checkbox"/>	<input type="checkbox"/>	<input type="checkbox"/>	<input type="checkbox"/>	<input type="checkbox"/>	<input type="checkbox"/>	<input type="checkbox"/>	<input type="checkbox"/>	
A	<input type="checkbox"/>	<input type="checkbox"/>	<input type="checkbox"/>	<input type="checkbox"/>	<input type="checkbox"/>	<input type="checkbox"/>	<input type="checkbox"/>	<input type="checkbox"/>	<input type="checkbox"/>	<input type="checkbox"/>	<input type="checkbox"/>	<input type="checkbox"/>	<input type="checkbox"/>	<input type="checkbox"/>		
B	<input type="checkbox"/>	<input type="checkbox"/>	<input type="checkbox"/>	<input type="checkbox"/>	<input type="checkbox"/>	<input type="checkbox"/>	<input type="checkbox"/>	<input type="checkbox"/>	<input type="checkbox"/>	<input type="checkbox"/>	<input type="checkbox"/>	<input type="checkbox"/>	<input type="checkbox"/>	<input type="checkbox"/>		
C	<input type="checkbox"/>	<input type="checkbox"/>	<input type="checkbox"/>	<input type="checkbox"/>	<input type="checkbox"/>	<input type="checkbox"/>	<input type="checkbox"/>	<input type="checkbox"/>	<input type="checkbox"/>	<input type="checkbox"/>	<input type="checkbox"/>	<input type="checkbox"/>	<input type="checkbox"/>	<input type="checkbox"/>	<input type="checkbox"/>	
D	<input type="checkbox"/>	<input type="checkbox"/>	<input type="checkbox"/>	<input type="checkbox"/>	<input type="checkbox"/>	<input type="checkbox"/>	<input type="checkbox"/>	<input type="checkbox"/>	<input type="checkbox"/>	<input type="checkbox"/>	<input type="checkbox"/>	<input type="checkbox"/>	<input type="checkbox"/>	<input type="checkbox"/>		
E	<input type="checkbox"/>	<input type="checkbox"/>	<input type="checkbox"/>	<input type="checkbox"/>	<input type="checkbox"/>	<input type="checkbox"/>	<input type="checkbox"/>	<input type="checkbox"/>	<input type="checkbox"/>	<input type="checkbox"/>	<input type="checkbox"/>	<input type="checkbox"/>	<input type="checkbox"/>	<input type="checkbox"/>		
F	<input type="checkbox"/>	<input type="checkbox"/>	<input type="checkbox"/>	<input type="checkbox"/>	<input type="checkbox"/>	<input type="checkbox"/>	<input type="checkbox"/>	<input type="checkbox"/>	<input type="checkbox"/>	<input type="checkbox"/>	<input type="checkbox"/>	<input type="checkbox"/>	<input type="checkbox"/>	<input type="checkbox"/>	<input type="checkbox"/>	

	F80	F81	F82	F83	F84	F85	F86	F87	F88	F89	F8A	F8B	F8C	F8D	F8E	F8F
0			<input type="checkbox"/>	<input type="checkbox"/>	<input type="checkbox"/>											
1			<input type="checkbox"/>	<input type="checkbox"/>	<input type="checkbox"/>											
2			<input type="checkbox"/>	<input type="checkbox"/>	<input type="checkbox"/>											
3			<input type="checkbox"/>	<input type="checkbox"/>	<input type="checkbox"/>											
4			<input type="checkbox"/>	<input type="checkbox"/>	<input type="checkbox"/>											
5			<input type="checkbox"/>	<input type="checkbox"/>	<input type="checkbox"/>											
6			<input type="checkbox"/>	<input type="checkbox"/>	<input type="checkbox"/>											
7		<input type="checkbox"/>	<input type="checkbox"/>	<input type="checkbox"/>	<input type="checkbox"/>											
8		<input type="checkbox"/>	<input type="checkbox"/>	<input type="checkbox"/>	<input type="checkbox"/>											
9		<input type="checkbox"/>	<input type="checkbox"/>	<input type="checkbox"/>												
A		<input type="checkbox"/>	<input type="checkbox"/>	<input type="checkbox"/>												
B		<input type="checkbox"/>	<input type="checkbox"/>	<input type="checkbox"/>												
C		<input type="checkbox"/>	<input type="checkbox"/>													
D		<input type="checkbox"/>	<input type="checkbox"/>													
E		<input type="checkbox"/>	<input type="checkbox"/>													
F		<input type="checkbox"/>	<input type="checkbox"/>	<input type="checkbox"/>												

Table 3.3 – Code Table of the HKSCS outside the PUA of ISO 10646 v1.0

The following is an example of a typical cell in this table:

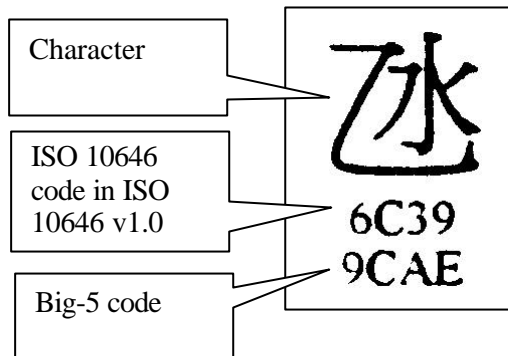

¨ 00A8 C6D8	ō 00F3 8875	ū 016B 8878	ı 026A C8FE	К 041A C7FE	Ъ 042A C84F	к 043A C860	ъ 044A C870	iv 2173 C6B8	⑦ 2466 C6A7	┘ 2552 F9E6	┘ 2562 F9F4	々 3005 C6E0	ぎ 304E C6F4	ぞ 305E C745	の 306E C755
À 00C0 8859	ø 00F8 C8FB	Ǻ 01CD 8858	ø 0275 C8F9	Л 041B C840	Ы 042B C850	л 043B C861	ы 044B C871	v 2174 C6B9	⑧ 2467 C6A8	┘ 2553 F9EF	┘ 2563 F9E2	↗ 3006 C6E1	く 304F C6F5	た 305F C746	は 306F C756
Á 00C1 8857	ù 00F9 887B	ǻ 01CE 8869	ſ 0283 C8F5	М 041C C841	Ь 042C C851	м 043C C862	ь 044C C872	vi 2175 C6BA	⑨ 2468 C6A9	┘ 2554 F9DD	┘ 2564 F9E7	○ 3007 C6E2	ぐ 3050 C6F6	だ 3060 C747	ば 3070 C757
È 00C8 885D	ú 00FA 8879	ǿ 01D0 8872	ı̇ 028A C8FD	Н 041D C842	Э 042D C852	н 043D C863	э 044D C873	vii 2176 C6BB	⑩ 2469 C6AA	┘ 2555 F9E8	┘ 2565 F9F0	あ 3041 C6E7	け 3051 C6F7	ち 3061 C748	ぱ 3071 C758
É 00C9 885B	ü 00FC 88A2	Ǿ 01D1 8860	ˆ 02C6 C6D9	О 041E C843	Ю 042E C853	о 043E C864	ю 044E C874	viii 2177 C6BC	(1) 2474 C6AB	┘ 2556 F9F1	┘ 2566 F9DE	あ 3042 C6E8	げ 3052 C6F8	ぢ 3062 C749	ひ 3072 C759
Ê 00CA 8866	Ā 0100 8886	ǿ 01D2 8876	È 0401 C7F9	П 041F C844	Я 042F C854	п 043F C865	я 044F C875	ix 2178 C6BD	(2) 2475 C6AC	┘ 2557 F9DF	┘ 2567 F9ED	い 3043 C6E9	こ 3053 C6F9	っ 3063 C74A	び 3073 C75A
Ë 00D2 8861	ā 0101 8867	ǿ 01D4 887A	À 0410 C7F3	Р 0420 C845	а 0430 C855	р 0440 C866	ë 0451 C85B	x 2179 C6BE	(3) 2476 C6AD	┘ 2558 F9EC	┘ 2568 F9F6	い 3044 C6EA	ご 3054 C6FA	っ 3064 C74B	ぴ 3074 C75B
Ë 00D3 885F	Ē 0112 885A	ū 01D6 887C	Б 0411 C7F4	С 0421 C846	б 0431 C856	с 0441 C867	Ê 1EBE 8863	↖ 21B8 C877	(4) 2477 C6AE	┘ 2559 F9F5	┘ 2569 F9E4	う 3045 C6EB	さ 3055 C6FB	づ 3065 C74C	ふ 3075 C75C
à 00E0 886A	ē 0113 886C	ü 01D8 887D	В 0412 C7F5	Т 0422 C847	в 0432 C857	т 0442 C868	ê 1EBF 88A4	↔ 21B9 C878	(5) 2478 C6AF	┘ 255A F9E3	┘ 256A F9EA	う 3046 C6EC	ざ 3056 C6FC	て 3066 C74D	ぶ 3076 C75D
á 00E1 8868	Ë 011A 885C	ü 01DA 887E	Г 0413 C7F6	У 0423 C848	г 0433 C858	у 0443 C869	Ê 1EC0 8865	↑ 21E7 C876	(6) 2479 C6B0	┘ 255B F9EE	┘ 256B F9F3	え 3047 C6ED	し 3057 C6FD	で 3067 C74E	ぶ 3077 C75E
è 00E8 886F	ë 011B 886E	ü 01DC 88A1	Д 0414 C7F7	Ф 0424 C849	д 0434 C859	ф 0444 C86A	è 1EC1 88A6	① 2460 C6A1	(7) 247A C6B1	┘ 255C F9F7	┘ 256C F9E1	え 3048 C6EE	じ 3058 C6FE	と 3068 C74F	へ 3078 C75F
é 00E9 886D	ī 012B 8870	ɸ 0250 C8F6	Е 0415 C7F8	Х 0425 C84A	е 0435 C85A	х 0445 C86B	No. 2116 C8D2	② 2461 C6A2	(8) 247B C6B2	┘ 255D F9E5	┘ 256D F9FA	お 3049 C6EF	す 3059 C740	ど 3069 C750	べ 3079 C760
ê 00EA 88A7	η 014B C8FC	α 0251 886B	Ж 0416 C7FA	Ц 0426 C84B	ж 0436 C85C	ц 0446 C86C	Tel 2121 C8D3	③ 2462 C6A3	(9) 247C C6B3	┘ 255E F9E9	┘ 256E F9FB	お 304A C6F0	ず 305A C741	な 306A C751	ぺ 307A C761
ì 00EC 8873	Ō 014C 885E	о 0254 C8F8	З 0417 C7FB	Ч 0427 C84C	з 0437 C85D	ч 0447 C86D	i 2170 C6B5	④ 2463 C6A4	(10) 247D C6B4	┘ 255F F9F2	┘ 256F F9FD	か 304B C6F1	せ 305B C742	に 306B C752	ほ 307B C762
í 00ED 8871	ō 014D 8874	ε 025B C8F7	И 0418 C7FC	Ш 0428 C84D	и 0438 C85E	ш 0448 C86E	ii 2171 C6B6	⑤ 2464 C6A5	— 2550 F9F9	┘ 2560 F9E0	┘ 2570 F9FC	が 304C C6F2	ぜ 305C C743	ぬ 306C C753	ぼ 307C C763
ò 00F2 8877	æ 0153 C8FA	g 0261 88A8	Й 0419 C7FD	Щ 0429 C84E	й 0439 C85F	щ 0449 C86F	iii 2172 C6B7	⑥ 2465 C6A6	 2551 F9F8	┘ 2561 F9EB	* 273D C6E6	き 304D C6F3	そ 305D C744	ね 306D C754	ぽ 307D C764

ま 307E C765	わ 308E C775	エ 30A7 C7A3	シ 30B7 C7B3	デ 30C7 C7C3	ブ 30D7 C7D3	ヨ 30E7 C7E3	一 30FC C6E3	义 4E49 FAE5	亿 4EBF 89D2	佻 4F72 96EA	倮 502E 92A8	儂 50FC 92AE	秣 51A7 9E55	瀆 51DF FDD8	劓 5257 FAB4
み 307F C766	わ 308F C776	エ 30A8 C7A4	ジ 30B8 C7B4	ト 30C8 C7C4	ヘ 30D8 C7D4	ヨ 30E8 C7E4	、 30FD C6DA	し 4E5A C87B	从 4ECE 9FCF	佻 4F8A 926F	倮 5034 9163	儂 5101 FA67	富 51A8 92BA	凵 51E2 FAA9	勑 5259 92C4
む 3080 C767	る 3090 C777	オ 30A9 C7A5	ス 30B9 C7B5	ド 30C9 C7C5	ベ 30D9 C7D5	ラ 30E9 C7E5	ゞ 30FE C6DB	フ 4E5B 8BC6	仪 4EEA 9DA9	倂 4FA2 92A3	倂 5056 9F73	儂 510D 92A2	彡 51AB C6C5	夙 51E4 8954	劓 5260 9F6F
め 3081 C768	ゑ 3091 C778	オ 30AA C7A6	ズ 30BA C7B6	ナ 30CA C7C6	ペ 30DA C7D6	リ 30EA C7E6	(株) 5231 C8D1	厶 4E6A 9C57	佻 4EEB 89D3	倂 4FA8 8950	倂 5058 92AD	儂 510E FA69	冲 51B2 FA7D	凭 51ED FAAB	劓 5268 8BB0
も 3082 C769	を 3092 C779	カ 30AB C7A7	セ 30BB C7B7	ニ 30CB C7C7	ホ 30DB C7D7	ル 30EB C7E7	上 4E04 9EB3	𠂇 4E78 9AFB	佻 4EEE 99E2	倂 4FAB FA57	倂 5066 9BE9	儂 512B 9268	决 51B3 FAA8	凭 51F4 FC7A	劓 5273 9FAC
や 3083 C76A	ん 3093 C77A	ガ 30AC C7A8	ゼ 30BC C7B8	ヌ 30CC C7C8	ボ 30DC C7D8	レ 30EC C7E8	业 4E1A 9EB2	龜 4E80 89D0	佻 4EF8 9267	倂 4FB0 9866	倂 506C 92A9	兗 5156 8951	冫 51B4 9A68	凵 51FC 89E0	劓 5279 89E3
や 3084 C76B	ゝ 309B C8D4	キ 30AD C7A9	ソ 30BD C7B9	ネ 30CD C7C9	ポ 30DD C7D9	ロ 30ED C7E9	东 4E1C 9DD6	乾 4E81 89CF	仔 4F03 92A4	倂 4FBD 89D6	倂 5081 92AA	兗 5160 FA6F	况 51B5 FA47	凵 51FE 9F4F	劓 528F 9BD3
ゆ 3085 C76C	〇 309C C8D5	ギ 30AE C7AA	ゾ 30BE C7BA	ノ 30CE C7CA	マ 30DE C7DA	ワ 30EE C7EA	両 4E21 994F	丿 4E85 C6C1	会 4F1A 894E	倂 4FC8 98B2	儂 5088 89D9	兗 516A FA71	泮 51B8 FA7E	凵 5202 C87D	劓 5290 89E4
ゆ 3086 C76D	ゝ 309D C6DC	ク 30AF C7AB	タ 30BF C7BB	ハ 30CF C7CB	ミ 30DF C7DB	ワ 30EF C7EB	两 4E24 89CE	𠂇 4E87 89D1	佻 4F28 894F	倂 4FCC 92AB	儂 5090 FD56	兴 5174 8952	涂 51C3 92BB	办 5205 89E1	劓 5294 FAB5
よ 3087 C76E	ゞ 309E C6DD	グ 30B0 C7AC	ダ 30C0 C7BC	バ 30D0 C7CC	ム 30E0 C7DC	𠂇 30F0 C7EC	争 4E28 8BC0	争 4E89 89E2	佻 4F29 9278	倂 4FE4 96DE	儂 50A6 9FA8	兹 5179 945A	凵 51C7 FDB6	刊 520B FAB0	劓 529A 9FD5
よ 3088 C76F	ア 30A1 C77B	ケ 30B1 C7AD	チ 30C1 C7BD	パ 30D1 C7CD	メ 30E1 C7DD	𠂇 30F1 C7ED	个 4E2A 9FC4	亘 4E98 927E	佻 4F32 91B6	倂 4FE5 92AC	儂 50CD 92A1	凵 5182 C6C3	凉 51C9 FAA2	劓 521F 9FCD	务 52A1 8955
ら 3089 C770	ア 30A2 C77C	ゲ 30B2 C7AE	ヂ 30C2 C7BE	ヒ 30D2 C7CE	モ 30E2 C7DE	ヲ 30F2 C7EE	丩 4E2C 8BD4	亚 4E9A 9DBA	佻 4F37 89D4	倂 4FF2 9F6E	儂 50D0 90E3	凵 5186 89DD	減 51CF FAA3	删 5220 A0E7	勑 52A4 92C5
り 308A C771	イ 30A3 C77D	コ 30B3 C7AF	ツ 30C3 C7BF	ビ 30D3 C7CF	ヤ 30E3 C7DF	ン 30F3 C7EF	、 4E36 C6BF	一 4EA0 C6C2	但 4F39 9FD2	倂 4FF9 8EF2	儂 50D9 A0A6	凵 5188 C8A2	湊 51D1 FAA4	劓 5226 FAB1	动 52A8 8956
る 308B C772	イ 30A4 C77E	ゴ 30B4 C7B0	ツ 30C4 C7C0	ピ 30D4 C7D0	ヤ 30E4 C7E0	ヴ 30F4 C7F0	𠂇 4E37 8BF9	廉 4EB7 FBF8	征 4F42 92A7	倂 4FFD 9F6C	儂 50DF 94AB	一 5196 C6C4	澧 51D2 9BB4	劓 5227 89A6	券 52B5 FAB3
れ 308C C773	ウ 30A5 C7A1	サ 30B5 C7B1	ヅ 30C5 C7C1	フ 30D5 C7D1	ユ 30E5 C7E1	カ 30F5 C7F1	丽 4E3D 8946	イ 4EBB 8BC7	佻 4F45 95A2	倂 5003 89D8	儂 50E1 FC72	凵 519A 9E52	凵 51D3 FAA6	劓 5234 9EFA	劓 52B9 FAB6
ろ 308D C774	ウ 30A6 C7A2	ザ 30B6 C7B2	テ 30C6 C7C2	ブ 30D6 C7D2	ユ 30E6 C7E2	ケ 30F6 C7F2	丩 4E3F C6C0	亼 4EBC 926B	佻 4F4B 926E	倂 5008 FA59	儂 50F4 97C4	衣 519C 8953	凵 51DB 89DF	劓 523C FAB2	勑 52C5 FAB7

勑 52CC 9EDC	卞 535F 8B61	斲 53AE FADD	𠂔 53FE FB59	𠂔 5493 89F0	𠂔 54EF 89F5	嗜 556B 94DC	𠂔 55DE 9E43	𠂔 5637 FB4F	嘉 569E 925E	𠂔 571D 92E2	垺 578D 92E7	𠂔 57FE FAE6	𠂔 589A 9EBD	𠂔 5905 89DE	𠂔 59B8 92F1
勑 52D0 FBC4	𠂔 5364 9AF1	𠂔 53B0 89E9	吓 5413 FAEF	𠂔 5494 9E47	𠂔 5502 97A7	𠂔 5571 95DA	𠂔 55EA 9DE9	𠂔 5643 9DEB	𠂔 569F 91C1	𠂔 5732 94A7	𠂔 5790 FC67	𠂔 5803 FB69	𠂔 58A7 9EE6	𠂔 5907 895E	𠂔 59C4 97DF
勑 52D1 9F71	卧 5367 9EB7	𠂔 53B6 C6C9	𠂔 5414 96EF	𠂔 5497 9DF7	𠂔 550D 93BA	𠂔 5572 9DF8	𠂔 55EC 8F52	𠂔 564D FB54	𠂔 56A1 8AC5	𠂔 573F 9BD4	𠂔 579C 8B7D	𠂔 5812 97E5	𠂔 58AA FB6F	𠂔 590A C6CA	𠂔 59C9 FBA6
勑 52E0 FABA	𠂔 5369 C6C8	叁 53C1 FAE2	𠂔 5416 9DEC	𠂔 549C 9FD3	𠂔 5513 9E58	𠂔 5573 9F6A	𠂔 55F0 9DF5	𠂔 564F FB55	𠂔 56A4 97A3	𠂔 5742 FB64	𠂔 57A1 9BF4	𠂔 5822 967D	𠂔 58B0 8EE1	𠂔 5911 FE42	𠂔 59D9 FBAB
勑 52E1 92C7	𠂔 536D FAD1	叁 53C2 89EB	𠂔 541A 9DCA	𠂔 549E 9ACA	𠂔 5518 89F6	𠂔 5579 8AB7	𠂔 55F1 9DF0	𠂔 5650 9AA2	𠂔 56AF 8B6C	𠂔 5743 FB76	𠂔 57A7 9EF7	𠂔 5826 FB6C	𠂔 58B5 9B7D	𠂔 591F FB7B	𠂔 59EB 9877
𠂔 52F9 C6C6	却 5374 FAD2	𠂔 53C5 FAE3	𠂔 5421 FD6D	𠂔 54A3 89F1	𠂔 551E 9E57	𠂔 5586 FB46	𠂔 55F5 99E7	𠂔 5652 8AD6	𠂔 56B1 8D7E	𠂔 5746 FB60	𠂔 57AA 9EC1	𠂔 583A 99A2	𠂔 58B6 9C7E	𠂔 5932 895F	𠂔 59F9 9854
𠂔 5301 9A4C	𠂔 537D 9EBA	双 53CC 90C8	𠂔 5423 89EC	𠂔 54A4 FAF9	𠂔 5523 89F7	𠂔 5590 8A46	𠂔 55FB 8BBD	𠂔 5654 9A5F	𠂔 56B9 9C54	𠂔 5754 99E5	𠂔 57B4 996F	𠂔 5840 9ABB	𠂔 58BB F9D9	𠂔 5934 8960	𠂔 59F0 95C5
𠂔 5327 89E5	𠂔 537E FAD4	𠂔 53D0 92DA	𠂔 542F FB44	𠂔 54B2 8E5A	𠂔 5525 8A41	𠂔 55A9 FB47	𠂔 5605 9DEF	𠂔 565D 9EF5	𠂔 56BF 9DBD	𠂔 5757 9AC2	𠂔 57BB 96F1	𠂔 5844 9A65	𠂔 58CB 92EA	𠂔 5965 9BCD	𠂔 59F8 9D55
𠂔 532C 9F7D	𠂔 5393 FAD9	发 53D1 8959	𠂔 5432 9DE2	𠂔 54B4 89F2	𠂔 5528 89F8	𠂔 55B0 9148	𠂔 5611 9FB7	𠂔 5661 8FB7	𠂔 56D6 9CC5	𠂔 575B 91FB	𠂔 57BE 8E41	𠂔 5847 944E	𠂔 58DC FB72	𠂔 5975 9DD3	𠂔 59F9 FBB2
𠂔 5332 A0A9	𠂔 53A0 FADB	𠂔 53D2 9CF5	𠂔 544B 9EC0	𠂔 54B9 89F3	𠂔 552B FAF1	𠂔 55B4 92DE	𠂔 561E 9DD0	𠂔 567A 9AD2	𠂔 56E2 895B	𠂔 575F A073	𠂔 57C4 954A	𠂔 585C FB6E	𠂔 58E0 FB71	𠂔 5989 984C	𠂔 5A02 957E
𠂔 5333 FAC4	𠂔 53A9 9CE0	变 53D8 895A	𠂔 544D 9E56	𠂔 54CB 925D	𠂔 553F 89FA	𠂔 55B9 8B53	𠂔 5620 9FEB	𠂔 567B 9E6A	𠂔 56ED FB5C	𠂔 5767 9F72	𠂔 57C8 97E6	𠂔 585F 99DF	𠂔 58F0 895C	𠂔 5994 9752	𠂔 5A0B 9742
𠂔 5338 C6C7	𠂔 53A6 FBF7	叙 53D9 FAE7	𠂔 5469 9F79	𠂔 54CC 8B51	𠂔 5547 FB42	𠂔 55BA 9DF6	𠂔 5621 8DA9	𠂔 567C 9EE8	𠂔 56EF FB5B	𠂔 577A 9FCC	𠂔 57D7 96F5	𠂔 5869 98E3	𠂔 58F2 98F0	𠂔 599A 95C3	𠂔 5A0D 94E6
𠂔 533B 8957	𠂔 53A8 FBFA	𠂔 53DA 9FA2	𠂔 546A 9AC7	𠂔 54CD 92E0	𠂔 5549 FABF	𠂔 55BC 9BDA	𠂔 5622 9DCF	𠂔 5689 8BBF	𠂔 56F1 FB57	𠂔 577E 98A5	𠂔 57DD 92E6	𠂔 586C 9254	𠂔 58F3 96F2	𠂔 599F 9BB6	𠂔 5A12 92F5
𠂔 5342 FAAA	𠂔 53A9 89E7	叠 53E0 FAEA	𠂔 546D FAF4	𠂔 54D0 89F4	𠂔 5553 FBA3	𠂔 55C1 9D7E	𠂔 5623 98E1	𠂔 568A 91C2	𠂔 56FD 98C7	𠂔 577F 92E8	𠂔 57DE 9F42	𠂔 5872 967B	𠂔 58FB FB74	𠂔 59AC 9AB9	𠂔 5A21 92FD
𠂔 534E 8958	𠂔 53AA A07A	叶 53F6 FAED	𠂔 5485 98A1	𠂔 54DA 9FD4	𠂔 555D FAF7	𠂔 55D7 89FD	𠂔 5625 9DE5	𠂔 568B 9D62	𠂔 5700 FB5A	𠂔 5788 9BBC	𠂔 57E6 FB67	𠂔 5873 8AAF	𠂔 5902 8BC1	𠂔 59B0 97B3	𠂔 5A24 FBA2
𠂔 535D 8BE3	𠂔 53AB FADC	号 53F7 8FAD	𠂔 548F FAF8	𠂔 54E3 8A79	𠂔 5569 9E4E	𠂔 55D8 99E4	𠂔 562D 9DC8	𠂔 5692 9260	𠂔 5715 9CEE	𠂔 578A 96F3	𠂔 57EF 99A9	𠂔 5899 8BAF	𠂔 5904 895D	𠂔 59B7 9F74	𠂔 5A27 9C51

媪 5A2A 94E9	娣 5A82 984D	嫺 5AFA F9DC	孳 5B7C FBC7	叅 5C1C 8B5D	峯 5CD1 9F58	峭 5D74 9EEA	冪 5E42 8D69	式 5F0D FC46	僿 5FBA A051	愆 60D7 8D71	傲 6160 FBCD	憶 61DA 90C3	拟 62DF FA51	搭 63E2 8DA2	搯 64AF FED4
媵 5A2B 985C	媿 5A86 9572	媿 5AFE 9672	宀 5B80 C6CB	寮 5C1E 934C	崢 5CE5 8D73	嵒 5D85 9CEB	冪 5E48 934F	式 5F0E 9362	卜 5FC4 8BCB	愆 60DE FD64	愆 6164 FC74	慳 61E2 A079	拥 62E5 8D7B	搯 63E6 9D4A	擻 64B4 8A78
媿 5A2C 92F0	媿 5A88 FDEF	媿 5B0D 9EB5	宀 5B82 FA79	寮 5C20 9AE2	崢 5CE9 FBDE	嵒 5D8B FBEO	冪 5E5E 934E	式 5F25 8D6B	帆 5FDB 936E	愆 60E3 99BA	傷 616F A074	戩 622C 8D79	撈 6318 8D7C	搯 63F8 FCB6	擻 64B6 93AB
媿 5A3D 944C	媿 5A91 FDC1	媿 5B11 964B	宀 5B90 9E67	允 5C23 8BC9	峯 5CEF FBDF	尉 5D8E 9F51	么 5E7A FBF4	强 5F3A FC4C	仗 5FDF FCD5	惧 60E7 9AD0	憾 617D A071	户 6237 8BFC	梯 632E 9ED6	撼 63FB 8DA3	擻 64C0 8DA7
媿 5A45 916B	媿 5A96 FBBA	媿 5B1F A0FA	宝 5B9D FBD2	屈 5C49 FBDB	崑 5D10 FBE3	崑 5DA4 8D65	广 5E7F C6CE	曠 5F4D 95B8	恚 6023 FCA9	惨 60E8 9A61	慳 6181 FC79	扈 6239 A076	抄 6331 93AC	搯 63FC 9E4B	擻 64D3 9F45
媿 5A54 8B78	媿 5A99 92EB	媿 5B2B 9575	实 5B9E 8962	届 5C4A 9FC9	崑 5D15 8DA8	嶧 5DAB 9CF1	庌 5E83 FBC3	彡 5F50 C6D0	忽 6031 FC61	愆 60E9 A0E5	愆 6187 FC7C	扈 624C 8BCD	搯 6335 9F5B	搯 63FE 9E4D	擻 64DD 8A56
媿 5A59 94E2	媿 5AA0 FC73	媿 5B41 90DA	实 5B9F 8963	肩 5C53 9F44	崑 5D18 FBE4	嶧 5DB6 FC58	庆 5E86 8965	彡 5F51 8BCA	总 603B 8966	愆 60FD A05B	愆 6195 9C50	扈 6268 9F5A	搯 6337 93A9	搯 6407 8DA4	擻 64E1 FCBF
媿 5A61 984F	媿 5AA1 97B7	媿 5B44 9367	宪 5BAA FC7D	属 5C5E 98ED	崑 5D2C 9C75	嶧 5DB9 8D66	庌 5EBD 8D6A	彡 5F5C 987A	協 604A FACB	愆 6107 96AC	愆 6198 9379	扈 6282 9F44	搯 6364 A07C	搯 6432 8AFD	擻 64E5 FCC0
媿 5A63 FBB5	媿 5AAB FBB4	媿 5B46 FEA4	冤 5BC3 9F6B	岷 5C85 FBDD	崑 5D2F 9878	嶧 5DC1 9654	庌 5ECD 9353	彡 5F61 C6D1	恒 6052 F9DA	愆 610C 9740	愆 6199 9378	扈 6285 9FBA	搯 636C FCB2	搯 6438 FCB5	擻 64E7 8EE6
媿 5A68 9271	媿 5AC3 90A7	媿 5B4A 90DF	寧 5BD5 FBCC	岷 5C99 8DF2	崑 5D3E 8D60	嶧 5DD7 FBE8	庌 5ED0 9DFB	彡 5F63 FC51	惠 6075 937A	愆 6119 9EF1	愆 619C A0DD	扈 6290 8D7A	搯 6379 8AC1	搯 643A FCC3	擻 64EA 8AA4
媿 5A6B 9365	媿 5ACE 9741	媿 5B4F 9354	寗 5BD7 FEAE	崑 5C9A 8964	崑 5D46 FBE5	嶧 5DDB C6CC	庌 5EF4 FBFD	彡 5F72 FC54	愆 6077 A0E0	愆 6130 9F7E	愆 61B7 8D75	扈 629D 9E45	搯 637F 9FB4	搯 643B 93B2	擻 650A 8943
媿 5A6E 985B	媿 5ACF 92F4	媿 5B66 8961	寶 5BF3 FBD1	岷 5C9C FDF2	崑 5D48 8D61	嶧 5DF5 9FCE	廴 5EF8 9059	彻 5F7B FAAF	忙 607E 936B	博 613D 8D72	愆 61B9 8D76	护 62A4 93B0	搯 638B FCAC	搯 645A 8DA5	擻 6511 93F3
媿 5A71 9850	媿 5AD3 FBBC	媿 5B68 8BB4	寿 5BFF FB75	岷 5C9E 934D	崑 5D56 8D62	岷 5E09 FBFC	廴 5EF9 FC40	徃 5F83 8D6C	悞 609E FC6B	愆 6142 FC76	愆 61C0 9374	扈 62A6 A075	搯 63B9 9E4C	搯 6471 93A1	擻 651E FCAB
媿 5A79 97BC	媿 5AE4 9577	媿 5B6D 9DC0	尅 5C05 FBD4	崑 5CBA FBE7	崑 5D57 A0A1	昏 5E0B 9AE4	廻 5EFB FC41	徃 5FA4 FA61	愆 60A4 A0DC	愆 6150 96A9	愆 61CF 8D77	扈 62C3 9B46	搯 63C1 8FC5	搯 647C 8AC6	擻 651F 9EA2
媿 5A7E 92F3	媿 5AF0 9EE2	媿 5B74 8E48	尔 5C13 FBD6	崑 5CC1 A0F2	崑 5D5B 9C40	岱 5E12 9F75	廴 5EFC FC43	徃 5FA7 FC57	悞 60A7 9468	愆 6159 A06E	愆 61D0 FCA5	扈 62C5 FCAE	搯 63D1 93AD	搯 648D 8A5B	擻 6530 9DC7
媿 5A81 9340	媿 5AF2 8F78	媿 5B76 FBC5	尔 5C14 FBD8	崑 5CC2 9868	崑 5D70 98AD	帮 5E2E FBF1	式 5F0C 9361	徃 5FB1 9B70	愆 60B3 FC6D	愆 615C FCAA	愆 61D3 FCA2	扈 62D5 FCB0	搯 63DE 9DC3	搯 6491 894D	擻 6534 C6D2

女 6535 8BCE	男 6618 FCD7	嵬 6692 8DB1	朶 6736 9CF9	柳 6801 FCFB	桼 685D FCFE	栞 6909 8DBD	楨 6985 8DC2	檣 6A0C 986C	櫟 6A82 8DC9	櫟 6AF6 8DD0	氩 6C31 9FD0	沓 6CAF 97D1	浚 6D72 92B7	湏 6E4F FDC0	滨 6EE8 8DE7
敍 654D FCC5	昞 661E 93DB	嗵 669A 9859	杆 6744 FA50	姆 6802 A07D	桥 6865 896A	楚 6918 9BA1	桡 698A 99B6	櫛 6A1A 97F9	櫛 6A8A FBF2	櫛 6B05 93F1	氩 6C35 8BD0	沓 6CB2 9EB6	浚 6D81 8DDA	湏 6E50 FCF9	滨 6EE9 8DE8
敷 655F FCCB	眈 6623 FE63	嗥 66A4 FB52	条 6761 98E7	枋 6803 98FC	栖 6884 8DB9	栲 691A 9AB7	榘 6998 FD52	櫛 6A1C 9558	櫛 6A8F 9670	櫛 6B1D FD62	水 6C37 FD72	泝 6CCB FAC7	湏 6D8F 9C5A	湏 6E59 FB7E	滨 6EFA FDC7
敷 656B 93B3	昞 6630 93D5	嗥 66AD FB53	空 6762 FCF3	荣 6804 8969	椋 6888 917E	栲 691B 8EFC	椋 699F 8DC1	櫛 6A2B 985E	櫛 6A99 8DCB	欸 6B35 FD65	氩 6C39 9CAE	泝 6CCE A042	湏 6D96 FDAD	湏 6E76 92B3	滨 6F04 FDB0
敷 656D FCCA	眈 6644 FCDA	瞿 66B3 FB4D	杌 6767 FCF2	柱 680D FE4F	椋 6898 93F4	植 692C 9FA1	椋 69A2 8E46	櫛 6A2C FE7B	櫛 6A9D FD5C	敵 6B52 9FDB	水 6C3A 8BD1	泝 6CDF 9873	湏 6DA4 8DDC	湏 6E7C FDAF	滨 6F0B 9445
敷 6585 FCC9	咬 6648 9B71	瞿 66B6 9CBF	枊 678F 93E5	楛 6810 9256	椋 68A6 FB7C	椋 6936 FD51	椋 69B2 A0D1	櫛 6A2D 94CD	櫛 6AA7 8F65	敵 6B57 93F8	余 6C3D 8ADB	泪 6CEA 9FFC	湏 6DA5 9444	湏 6E86 8DE1	滨 6F0C 97D6
敷 6586 8DAC	晋 664B FCDD	嘻 66BF 9B72	枊 67A0 9A59	枊 681B FAC9	椋 68B6 93E7	椋 693E FAAD	椋 69C0 9FCA	櫛 6A33 93EE	櫛 6AAB 8DCD	齒 6B6F 8BF7	汗 6C49 FAE4	泝 6D02 8DD7	湏 6DB1 8DDD	湏 6EB8 95D3	滨 6F16 FCC6
孝 6588 FBC6	晓 6653 8DAF	嗥 66CD FB50	杖 67A4 8DB5	栒 681E 93E8	椋 68B9 97EF	椋 6943 8DBE	椋 69D1 92CF	櫛 6A45 FDSA	櫛 6AB1 9DA8	歷 6B74 FD66	汗 6C58 95CE	泝 6D05 92FB	湏 6DB9 A0D6	湏 6E9A 89C1	滨 6F17 9844
齐 6589 8967	哈 6657 FAF2	嗥 66CE 93BE	枊 67AC FD4D	栒 6822 FCF8	椋 68BD FE4A	椋 6946 89A4	椋 69D5 9CF4	櫛 6A4C 93F5	櫛 6AB2 94F9	夕 6B7A 8BCF	污 6C5A FD76	泝 6D06 8DD8	湏 6E02 97D5	湏 6EB5 FD68	滨 6F24 8DE9
斲 65B5 FCCD	晰 6663 93D8	甲 66F1 9DF1	枊 67B1 FD5E	栒 6836 9CE3	梨 68C3 FD45	椋 6955 9AD9	椋 69D6 8DC4	櫛 6A52 93EF	櫛 6AB5 8DCE	歿 6B81 8DD1	沟 6C6E FB62	泝 6D24 944F	湏 6E04 944A	湏 6EB8 9CB7	滨 6F34 8DEA
旆 65BE 9CF3	皓 6667 FCDF	勗 6702 FCEB	枊 67BF 8F7D	样 6837 FDA9	楛 68C5 96A5	椋 6961 FD4E	椋 69E1 FD41	櫛 6A53 8EEA	櫛 6ABE 93EA	毀 6BC1 8DD2	泝 6C75 8DD4	泝 6D26 8DD9	湏 6E0A 944D	湏 6EBB 8DE3	滨 6F3D FE50
旆 65D1 FCD0	晫 666B 93D3	盼 670C A0BB	枊 67D6 9547	栒 683E FC44	棊 68CA FEE0	椋 6964 8DC0	椋 69E9 9B4C	櫛 6A57 8F5B	櫛 6AC8 FD5F	毡 6BDC FD71	泝 6C79 FD78	泝 6D4E 896B	湏 6E0F 97CB	湏 6ED9 FAC0	滨 6F44 FDCC
旆 65D4 95BB	皙 6673 FCE1	聆 670E 9B7E	枊 67D7 FCF6	架 6847 9640	椋 6900 FD48	椋 6967 97F0	椋 69F9 FD57	櫛 6A65 8DC6	櫛 6AC9 93F0	毡 6BE1 FD6F	泝 6C7F 8EE3	泝 6D57 97CE	湏 6E15 8DDE	湏 6EDA 8DE5	滨 6F56 9DA7
无 65E0 FCD3	琳 667D 8E76	胤 6716 8DB3	栒 67F9 9250	棊 684A 8DB8	椋 6901 FD47	椋 6972 93B4	椋 69FA FCEF	櫛 6A71 8DC8	櫛 6ACA 9FB6	毡 6BEA 8DD3	沟 6C9F 9076	泝 6D5B FAF3	湏 6E18 8DDF	湏 6EBD FA64	滨 6F5C FDCD
旆 65E3 FCD4	暄 6685 FC62	朥 671E 9AE8	枊 67FE 8968	栒 6855 9B4A	椋 6902 FEF2	椋 6973 FD44	椋 6A03 9CDE	櫛 6A74 8DC7	櫛 6AD4 8DCF	瑜 6BFA 9FE7	泝 6CA2 98C6	泝 6D5C FDAE	湏 6E29 8DE0	湏 6EDD 8947	滨 6F74 FDCF
昨 65FF 8DAE	曠 668E 93D1	勝 6725 8EDC	椋 6800 8DB6	椋 6856 8FB9	椋 6903 FE6A	椋 6980 9FA7	椋 6A0B FD42	櫛 6A7A 93F7	櫛 6AD8 9763	氩 6C1C 90BD	沪 6CAA 8DD5	泝 6D71 FBAF	湏 6E2A FEF9	湏 6EE2 8DE4	滨 6F79 95D2

澁 6F81 8DED	滢 7050 8DF6	焮 70A5 9770	窆 70FE 97E9	焠 716B 977E	焚 71AD 9CCC	𠂇 722B 8BD3	貉 72E2 A049	玏 738F 98AE	璆 73F3 9764	琮 743C 946B	璫 747A 945D	𠂇 74F8 A0CE	畧 7567 FEB3	瘡 7607 9FFE	皐 7690 FEC3
溥 6F8A FCBA	灑 7054 8DF7	焮 70A6 986F	焮 7105 9346	焮 7171 9BD5	焮 71B4 FDEA	𠂇 722E FE47	猥 7302 A04C	玏 7398 92D6	璆 73F7 FE68	琮 7443 92FC	璫 7482 FE7C	𠂇 7505 A0B7	畧 756D 98D3	瘡 762C FEBD	皐 76A1 FEC8
溥 6F9D FDC5	瀛 705C 8FFA	焮 70A7 FDE2	焮 711D 9863	焮 7173 9AC3	焮 71B7 8DF1	𠂇 7240 FE48	猥 7304 9E65	玏 739C FAE1	璆 73F9 964E	琮 7445 95EB	璫 748C 9344	𠂇 750E FEA9	畧 756E FEB4	瘡 763B 9DDD	皐 76A5 FEC9
凜 6F9F FDD2	灑 7067 97D0	点 70B9 98F2	焮 7129 95BC	焮 7175 97C8	焮 71BA FDFB	𠂇 7250 9455	猥 7310 98B5	玏 739E 91D4	璆 73FB 9765	琮 7447 FE73	璫 748D 8EA6	𠂇 7519 89C3	畧 7572 98D4	瘡 7640 9EE1	皐 76B7 FECA
漸 6FB5 9CDC	灑 706C 8BD2	焮 70BB 9AFC	焮 712B FDED	焮 7176 A0DB	焮 71D1 8E53	𠂇 7255 FE4B	猥 7328 FE58	玏 73A7 FADE	璆 7411 89A1	琮 7448 976E	璫 7499 92D3	𠂇 751E FEAB	畧 757A 9FB9	瘡 764D 98DA	皐 76CC FECB
澱 6FBB 95CF	灯 706F 8DF8	焮 70BC 896C	焮 712C FDF7	焮 7177 91D0	焮 71DD FACF	𠂇 7257 FE4C	猥 732A 9975	玏 73AA FE5B	璆 7412 95FA	琮 7449 FESF	璫 749B 94B8	𠂇 7534 9DF4	畧 7583 9471	瘡 764E 9DDF	皐 76D6 9FC2
澱 6FBE 8DEE	灵 7075 90D9	焮 70BD FDFD	焮 7133 9870	焮 717A 9FE4	焮 71EB 96F9	𠂇 725C 8DBF	猥 732B FE53	玏 73C9 FE5E	琮 7414 92D4	璫 7453 FDBD	璫 74A4 FC71	电 7535 896D	𠂇 758D 98D5	瘡 764F FEBF	皐 770C 98C4
濂 6FD3 FDD4	焮 7079 FAF0	焮 70C0 995E	焮 7134 96F6	焮 717C 8FDD	焮 71F5 98BF	𠂇 7266 9E78	猥 732C A065	玏 73CE FBD7	琮 7415 FE69	璫 7456 92D5	璫 74B4 975E	画 753B 9C7B	𠂇 758E FEB8	瘡 7651 FEBE	皐 770E 94B0
澱 6FD9 96EC	灾 707E FDE1	焮 70C4 95BD	焮 7135 8EA9	焮 717E 91E9	焮 71F6 9E49	𠂇 7282 FE51	猥 732E FE59	玏 73CF FESA	琮 7417 FB45	璫 745D FEB9	璫 74C8 FEA7	𠂇 7542 98D2	𠂇 7592 C6D4	瘡 7654 9EEB	皐 770F 94B1
澱 6FDA 96EB	灿 707F 8DF9	焮 70CC FDE4	焮 713B 9451	焮 7188 98E0	焮 7209 9BCA	𠂇 7287 9456	猥 7338 98B7	玏 73D0 94C5	琮 7419 98C8	璫 7460 FE71	璫 74CC 946A	𠂇 7546 9FA9	𠂇 759E FEBA	瘡 7666 9E59	皐 771E FED1
澱 6FF6 90B6	焮 7081 FDE3	焮 70D0 91E6	焮 713E 8E43	焮 718C 92CA	焮 720E FDFE	𠂇 728F 9D61	猥 7339 98B8	玏 73D5 FACA	琮 741C 90EF	璫 7465 FBBB	璫 74D0 93E3	𠂇 754A FEB2	𠂇 75B1 9E5C	瘡 7667 A05C	皐 772A A0C1
澱 6FF8 FDC3	焮 7089 8DFA	焮 70D5 FDE5	焮 7140 8B5A	焮 718E 9857	焮 720F 92DC	𠂇 7294 9457	猥 7341 98BA	玏 73E1 98C1	琮 741E 98C9	璫 7468 947A	璫 74D3 98CF	𠂇 754D FEB1	𠂇 75B4 FEBB	瘡 766F FEC0	皐 7726 FED2
澱 7003 98AB	焮 708B FB63	焮 70D6 FDE6	焮 7145 FDEE	焮 7196 FDEB	焮 7215 FE41	𠂇 729F 9966	猥 7348 98BB	玏 73E2 975C	琮 741F 98CA	璫 746B 95FB	璫 74E7 A0D9	𠂇 7551 97D9	𠂇 75C3 A044	瘡 7673 9477	皐 772B A0CD
澱 701E 96EE	焮 708F 90A6	焮 70DF FDE7	焮 714A FDF0	焮 7198 9B49	焮 7216 91CC	𠂇 72AD 8BD5	猥 734F 9FBC	玏 73E4 FE74	琮 7437 946D	璫 746C FE77	璫 74F0 A0BF	𠂇 7553 A0C4	𠂇 75C8 98D7	瘡 7674 98DC	皐 7740 FED3
澱 702C 8DF4	焮 70A0 9970	焮 70F1 9454	焮 714F FDF4	焮 71A2 9D76	焮 7217 91E2	𠂇 72B2 A069	猥 7371 A04A	玏 73E6 9773	琮 7438 94B7	璫 7474 FE79	璫 74F1 A04D	𠂇 7555 9476	𠂇 75DC 98D8	瘡 7676 FEC1	皐 7743 98E5
澱 704B FDE0	焮 70A3 91EB	焮 70F5 99B8	焮 7151 9BF5	焮 71A3 9EAF	焮 7224 FE44	𠂇 72CD 98B4	猥 7374 9EC7	玏 73EF FA46	琮 7439 FE6C	璫 7476 FE75	璫 74F2 A0B8	𠂇 7560 9978	𠂇 7602 FECB	瘡 767A 98DE	皐 7758 FED6

暹 7772 91E4	硲 7808 9D4C	碁 7881 F9D6	礪 78F5 90C5	裨 7986 FEF0	稽 7A2D A0B3	寵 7AC9 89A5	箣 7B27 954F	箠 7BFA 8E6E	粿 7C7E 9F5F	糝 7CE6 8E7A	緡 7DCD 89A3	縊 7E7F 9DA6	纒 7F4E 94FD	粗 801D 8ECF	胚 80A7 8EDD
睫 7777 8FC7	砵 7818 98F1	碛 7888 94C3	礮 7906 A0A8	褚 7987 89C9	穉 7A3A 94CF	汧 7ACF 994C	笱 7B29 8E5E	筥 7BFC 9F64	粃 7C83 8E73	糲 7CED 995C	縶 7DCF 9960	織 7E8E 9EB0	𠂇 7F52 8BD7	給 8020 9968	眈 80B6 9E5D
睪 7778 94AE	硯 781C 98F3	碍 788D 94C2	礮 792E FEE5	禍 7991 9941	稟 7A3E 9FFA	氐 7AD3 9FF8	筵 7B39 996A	篡 7C12 9953	粃 7C86 9F62	繫 7CF3 8E7C	緜 7DD0 9962	纏 7E92 8EB8	𠂇 7F53 8BDA	耑 8025 9969	眈 80B7 9971
睪 777A 8A4F	硯 781E 94C1	碛 78AF FEE1	礮 7932 98FD	禡 7999 9942	穉 7A43 91E5	汧 7ADA 8E56	箣 7B42 9C64	筥 7C15 FAB8	粃 7C8E 94F6	糲 7CF5 8E7D	緜 7DD3 94FC	纒 7E9F 9D70	罨 7F71 A0E2	耑 802E 996B	眈 80BC 89AE
暹 777B 94B2	砵 7839 98F5	碛 78B1 FEE9	礮 7933 98FB	禡 799D FEF5	穉 7A45 9C6A	汧 7ADB 994D	箣 7B43 9CD9	筥 7C1B 9954	粃 7C9C 9958	糲 7CF9 8BD9	緜 7DD4 9961	纒 7EA4 896E	罨 7F78 9FE9	耑 802F 8ED1	眈 80BD 9DE8
暹 7793 8FD4	砵 783C FA4F	碛 78B6 96E4	礮 7934 FEE8	禡 799F 91D7	穉 7A49 8E49	汧 7ADC 91CA	箣 7B55 8E5D	筥 7C35 8E70	粃 7CA6 8E75	糲 7CFC 89A2	緜 7DDC 94FA	纒 7EAC 896F	罨 7F8F FDA8	耑 8031 996C	胆 80C6 9565
暹 7798 98EA	硯 783D 96E2	碛 78B8 89AC	礮 7936 8EBF	禡 79A5 94CC	穉 7A65 8E4C	汧 7ADD 8E57	箣 7B62 9950	筥 7C42 9F61	粃 7CA7 F9DB	糲 7D25 9ED7	緜 7DE4 8EAE	纒 7EBA 8970	罨 7F93 8AE7	耑 803B 8ED4	眈 80E9 9972
暹 77AF FED8	砵 7842 9450	碛 78B9 96DB	礮 793B 8BD8	禡 79A9 FEF8	穉 7A7D 8E4D	汧 7AE2 94E1	箣 7B6C 9951	筥 7C44 8E72	粃 7CAC 9072	糲 7D4D A0B6	緜 7DE5 8EB2	纒 7EC7 8971	罨 7F97 8EC2	耑 803C 8ED5	胆 80EC 8B5C
暹 77B9 9DE0	砵 7844 96A2	碛 78C7 FEE2	礮 793C FEF7	禡 79C4 97A8	穉 7A83 9A73	汧 7AE7 9047	箣 7B6F 8E62	筥 7C51 A06B	粃 7CAE 94F8	糲 7D5A 9E42	緜 7DF5 8EB0	纒 7ECF 8972	罨 7FA3 8EC4	耑 8054 996D	胆 80F6 89B1
暹 77BE 98EE	硯 7847 98F6	碛 78D2 94C4	礮 7958 8F68	禡 79C6 FEFC	穉 7A91 9947	汧 7AE9 8FD8	箣 7B7B 9952	筥 7C56 9F40	粃 7CB8 995A	糲 7D5D 8EA4	緜 7DFD 9963	纒 7EDF 8973	罨 7FAE 9964	耑 805B A0BE	胆 8103 A0C0
暹 77C3 95C4	砵 784B 96E5	碛 78D3 FEE3	礮 7959 94C6	禡 79CC FDBF	穉 7AB0 8E50	汧 7AEA 8E58	箣 7B92 8E68	筥 7C5D 94ED	粃 7CC2 A0B0	糲 7D89 8EA7	緜 7DFE 97AA	纒 7F06 8974	罨 7FB4 9965	耑 8061 8ED6	胆 8107 8EDF
暹 77C5 FCE8	硯 7851 98F7	碛 78D7 FEE7	礮 7962 9DEA	禡 79D4 FEFE	穉 7ABB 8E4F	汧 7AFE 94EB	箣 7BA2 8E61	筥 7C6D 94EE	粃 7CC7 8E79	糲 7D97 9542	緜 7E07 94FB	纒 7F37 8975	罨 7FDD 954E	耑 8062 A0BC	胆 8109 9566
暹 77CB 98EF	砵 7853 A046	碛 78D8 9FFB	礮 7971 FC69	禡 79E2 96D1	穉 7ABC 9949	汧 7B0B 8E5C	箣 7BA3 9F59	筥 7C70 9FBD	粃 7CC9 8E78	糲 7DA4 987D	緜 7E27 8EBB	纒 7F40 8EBC	罨 7FE7 98B3	耑 8063 A0B5	胆 810C 9974
暹 77E6 FAD8	硯 7854 96E3	碛 78EE 93C9	礮 797E 9CDA	禡 79F1 94D5	穉 7AC2 8E51	汧 7B0C 9553	箣 7BB2 8BB3	筥 7C74 8E7B	粃 7CCD 94F3	糲 7DA8 9755	緜 7E65 9876	纒 7F41 8EBD	罨 7FFA 8ECB	耑 8066 A0B4	胆 810E 9976
暹 77F4 FEDC	硯 7866 98F8	碛 78F0 94E8	礮 7980 FEF3	禡 79F4 94D0	穉 7AC3 8E52	汧 7B14 9FE5	箣 7BCF 9F5D	筥 7C7B 9957	粃 7CD3 98AF	糲 7DAB 8EA8	緜 7E67 8EA1	纒 7F47 8EBE	罨 8002 8BDF	耑 8080 8BE0	胆 8112 9977
暹 77FE A0AE	硯 787A 9EE4	碛 78F1 FB56	礮 7983 9C72	禡 7A06 9944	穉 7AC8 9AB2	汧 7B1F 9F56	箣 7BD0 8E66	筥 7C7C 94F7	粃 7CDA A0B2	糲 7DB3 8EAA	緜 7E6E 8EB7	纒 7F49 9DD1	罨 8008 8ECE	耑 809F 89B5	胆 8114 9979

脛 8117 9DDA	臆 81AA 8ABE	艷 8276 99AF	菰 82FD 9B54	莹 83B9 FE76	藁 8448 98F9	蓀 84A3 95B1	菟 8538 99C1	蕓 8614 9368	蝻 877D FA7A	蠹 8827 9CB2	袴 88B4 8FC3	襪 8977 9C5D	訖 8A2B 95E5	謫 8B2D A04B	負 8C9F 95C0
脚 811A 8EE0	潤 81B6 9E61	𠂇𠂇 8279 994A	茱 82FF 99B2	莽 83BE 9FC6	莽 844A 8F66	葛 84AD 9AF2	勝 8542 FAB9	藜 8616 8F7E	蠟 8786 9E5F	蠶 882D 957C	衽 88B5 8FC4	西 8980 98E2	詆 8A38 99D7	謫 8B3F 8FE2	質 8CAD A0CB
晞 812A 935C	臙 81C1 99AA	艺 827A 8976	苾 830B 9E68	葱 83CD FAAC	苙 8453 956E	蔥 84BD 96C3	藟 854B 8F40	藜 8628 8FAA	蝮 878B 99CD	𠂇 8842 9FC7	桂 88BF 95A4	霸 8987 8FC9	詢 8A3D 95B5	謫 8B43 A0CC	贓 8CCD 9E48
脉 8132 9DE6	臙 81C8 A0C8	芳 827B 8F48	荔 8318 8F4A	菓 83D3 8F58	苻 8455 9245	苳 84BE 99BD	藟 854C FA44	藜 862F A050	蟹 878C A0C9	𠂇 8845 8FBB	装 88C5 8FC6	羈 8989 A0C2	誨 8A49 A0CA	譌 8B4C 8FE3	賔 8CD4 99DB
脛 8134 8B5F	𠂇 81E4 99AB	芾 8287 FBEE	茆 831A 8F42	落 83ED 9848	蓄 8458 8F60	蓀 84DA A0CF	蕓 8552 99C2	藜 8642 90D3	蟾 87A5 9ADB	衆 8846 8FBC	衽 88C7 9E60	羈 898A 8FCA	譽 8A67 9FFD	鷹 8B4D 8FE4	賒 8CD6 8FF3
脛 8137 9563	臙 81EF FEC4	芦 82A6 99AE	茆 831D 8F51	萑 8405 99B7	藜 845C 9ED1	蓀 84DE 8F6D	萑 855A 8F5C	騰 8645 9556	蝮 87A9 A0C6	衍 884F 8FEC	裏 88CF F9D8	規 8991 99D4	詢 8A7E A058	譌 8B5E 9BC4	贊 8CDB 8FF9
裸 8142 9567	莛 81F6 98C2	茆 82AA 8EFB	茆 833D 9846	莛 8414 9665	蓋 8462 FECF	葭 84E1 99BE	蔞 856F 99C4	虬 866C 8FB8	蟹 87B1 8FB4	衛 885E 8FC0	裏 88E6 95A5	覓 8994 A0B9	譌 8A90 8FD6	譌 8B62 9BFC	賒 8CE9 95C1
脛 8148 9DE3	館 8218 8EE8	芾 82C4 8B52	茆 8357 99B4	莛 8416 FAGC	藜 8464 99B9	萌 84E2 8EF4	蔞 8570 99C5	虬 8672 99C8	蟲 87C1 A0D7	衡 8860 936A	裏 88F5 9CB3	覓 89A5 9B58	誕 8A94 99D8	譌 8B69 964C	賚 8CEB A04E
臙 8156 997C	瞻 821A A0BA	芾 82CA 99B0	芋 8362 8EF5	萑 8418 9DE7	葱 8471 8F62	蔞 84E4 8F72	蔞 8573 8F7B	虬 867E 8FAF	蝮 87CE A0C7	𠂇 8864 8BE4	椅 88FF 99D1	覽 89A7 8FCD	諛 8A9C 8FD3	譌 8B81 9AF6	賃 8CF2 99DC
賒 8159 997D	𠂇 8226 FD77	苏 82CF 8977	茱 8363 FD55	萑 841C 9E62	藁 8472 974C	蓋 84E5 95E4	藁 85C1 8FA3	𠂇 8692 99C9	蝮 87D6 A043	补 8865 9C7C	棋 8900 FEF1	覓 89A9 A0D4	言 8AA9 8FE5	讐 8B90 8FE7	賚 8CF7 A064
脛 815A 997E	舩 8229 8EEE	第 82D0 8F41	萃 8366 9CCD	萌 8420 96CC	萑 847F 91C7	萑 84F8 99BF	藟 85E0 99C6	𠂇 86A0 9579	蝮 87DA 8FB5	袞 886E 95A1	襖 8924 99D2	覓 89BC 8FCE	詡 8AAF 8FE9	讐 8B9B 8FE8	聽 8D03 8FF7
脛 816D 8B5B	舩 822D 9EBF	茆 82D8 99B1	药 836F 8978	茆 8421 8E67	萑 8480 955F	蔞 8503 9242	藟 85EE 96CD	𠂇 86AD 9F49	蟻 87EE 8FB2	𠂇 8884 FEFC	裏 8943 9CC2	见 89C1 8BE5	諛 8AB4 99D9	𠂇 8BA0 8BE7	賚 8D0B 89B0
脛 817C 99A3	舩 823E 89C2	苜 82E2 8F49	茆 8385 8F53	茆 8424 FC75	萑 8488 99BB	藟 8505 FBA5	藟 85FC 96C7	𠂇 86B2 99CA	蝮 87F5 A061	衽 8887 95A3	襖 8947 99D3	視 89C6 8979	諛 8ADA 927C	設 8BBE 897A	賚 8D0C A048
臙 8184 99A4	艘 8254 99AC	苜 82EE FA4D	萑 8391 8F6F	索 8426 987E	萑 8492 8E6D	萑 8510 99C0	藟 8602 8FA5	蛭 86EF 99CB	螻 8804 9E5E	袜 889C 8FC1	襖 894D 95A7	鮮 89E7 8FD0	諛 8AEA 9C45	詢 8BE2 897B	蕓 8D11 8FFB
臙 8193 99A6	艦 8262 956B	苜 82F7 9DE4	茆 839C 8E63	萑 842E FDB9	萑 8493 8F71	萑 8533 FDB4	藟 860D FABB	蝮 8770 9DD5	蠟 880F 8FB6	袞 88A0 A052	襖 8954 95A9	諛 8A1C 95B6	譌 8B0C 8FDE	讐 8C51 99DA	賚 8D12 8FF6
藟 81A5 99A8	舩 8265 956C	茆 82FC FBE9	茆 83AC 8F56	蓋 843E 97FC	蕓 8496 94CB	藟 8534 8F77	藟 8610 9570	𠂇 8771 8FB0	蠟 8818 9FE8	衽 88AE 99D0	襖 8965 95A6	諛 8A29 99D6	諛 8B1F 8FDF	讐 8C9B 8FED	賚 8D18 9DDC

臟 8D1C 99DD	蹶 8E4F 9FF1	軒 8EE4 99EC	辵 8FB5 C6D6	逶 9012 9D79	酌 9167 906E	鈎 920E 9075	鉷 9277 96DC	鍪 92EC 91DD	鋈 9345 9DE1	鋤 9386 9779	鐳 93F1 FE7A	鑿 944D 96DD	錠 952D 9A53	阳 9633 9A57	霽 971B 90DB
貝 8D1D 8BE8	蹶 8E68 8AA7	輗 8EED 99ED	辵 8FB6 9AA8	逶 9033 99F3	醜 9170 9E71	鈎 9213 99F7	鈎 9281 9CA8	鋈 92F2 93FC	鋈 9348 96D9	鋤 9387 946C	鐳 93F3 91DB	鑿 9454 9A51	鎮 9547 9D74	院 9638 A0AA	霽 9721 A066
趁 8D7A 92C1	躡 8E71 99E6	帖 8EF2 99EE	辵 8FB7 99EF	逶 9037 9062	酶 9176 9E4A	鈎 9228 99F9	鈎 9284 9772	鑄 92F3 9A42	錕 935F 9774	錕 9390 9858	鋸 9401 97AF	鋤 9458 96A7	長 9578 8BEA	阝 9641 9FA6	霽 9731 90D2
趁 8D82 9FD6	蹶 8E75 9FF7	輗 8F19 904C	辵 8FB8 FEEB	逶 904C 9F55	醜 917C 9FDC	鉅 922A 9663	肆 9289 9440	銳 92F4 9A43	鋤 9362 FDF5	鑿 939C 9266	鑿 9404 95DD	鑿 945B 90B0	長 957F 8BEB	际 9645 99CC	霽 9736 90D4
趨 8DA6 A0D2	蹶 8E77 9FED	輗 8F2D 904D	边 8FB9 9DA3	逶 9056 9BF9	醜 918C 89AB	鉅 922B 95B9	肆 928F 92F2	銳 92F6 9659	鋤 9366 92E5	鑿 93A0 93FB	鑿 9408 9348	鑿 9465 9C4E	閔 9585 90B2	陵 9656 9C59	霽 9740 9A5B
趨 8DA9 9040	躡 8E7E 8A5C	暢 8F30 95CB	边 8FBA 9DA1	遡 9061 9065	醜 918E 9FB8	鈎 9235 94D4	銜 92AE 99FD	鋈 92FD 9A44	鍪 9368 9645	鎮 93AD 9A47	鋤 9417 9A4B	鑿 9467 9443	閔 9596 95E9	險 9669 99B5	霽 9741 95FD
踴 8DC0 8AC4	躡 8E80 9DAE	輗 8F41 97E2	辵 8FBB 9943	馮 9064 96E0	醜 91A9 9070	鉅 923C FCFA	銜 92B1 99FC	鍪 9303 9051	鋈 9369 91DA	鑿 93B8 9749	鑿 941B FC45	鑿 946C 8EBA	閔 9597 95E8	陞 967B 90BE	青 9751 8BC4
跃 8DC3 99E0	躡 8EA7 95C9	轉 8F4A 95CC	辵 8FBC 9945	遡 906C 98BE	醜 91B6 8B63	鈎 9241 9077	銜 92B9 F9D7	鍪 9307 94BF	鍪 936B 90A3	鑿 93BB 9748	鑿 941D 9A4D	鑿 9479 9A52	閔 9599 95E6	陞 9681 9FAF	靛 9757 90DE
踴 8DD4 9FF0	躡 8EAD 9048	輗 8F5C 9F78	达 8FBE 9D7D	邨 90A8 9068	醜 91BB 95DC	鐵 9244 90AB	銜 92BA 964A	鍊 932C 90A2	鍪 936E A05F	鑿 93BD 934A	鑿 9424 91BC	鑿 947B FCC1	閔 95A0 90B5	隨 968F 95F2	靛 975D 9CE4
踴 8E01 9FF3	躡 8EB0 99E8	车 8F66 897C	辵 8FC1 99F0	邨 90AE 906C	醜 91C4 9071	鉅 9255 9D4D	銜 92BE 96D8	鍪 9330 9CAB	鑿 9373 90AF	鑿 93BF 9CE2	鑿 9425 90E2	车 9485 8BE9	閔 95A2 9A54	陞 9696 90BF	靛 975F 90E1
踴 8E0E 9DBF	躡 8EB6 9049	軋 8F67 897D	迓 8FCA 99F1	邨 90BB 95D8	鈎 91D6 FC5E	鈎 9258 99FA	銜 92BF 99FE	鍪 9331 9776	鑿 9374 97BF	鑿 93C6 9264	鑿 9426 90B4	钟 949F 9CAF	閔 95A6 90B3	隣 96A3 90C1	靛 976D 9E46
踴 8E28 9FF6	躡 8EBC 90B1	轮 8F6E 897E	迓 8FCC 99F2	邨 90C4 906A	鈎 91DF 8949	鈎 925D 92E3	銜 92D4 904B	鍪 9340 FC55	鍪 9378 914C	鑿 93CB 91DF	鑿 9427 95E1	钢 94A2 8BFD	閔 95A7 95E7	陞 96A5 FE44	靛 9771 9651
踪 8E2A 95C8	躡 8EC3 904A	输 8F93 995D	运 8FD0 9D60	酌 9151 9FB2	鈎 91E5 965B	鈎 925F 97BB	銜 92DB FA41	鍪 9341 FE45	鍪 937D 967A	鑿 93D3 FB79	鑿 942D 9A4E	铁 94C1 9ABC	閔 95AA 8B50	隶 96B6 90C4	靛 9789 FB58
踴 8E2D 9E5A	躡 8ECE 99EA	鼻 8FA0 9B5A	迓 8FDA A0A3	酌 9159 9FAE	鈎 91FA 94A6	鈎 9262 9078	銜 92E3 9A40	鍪 9342 94A8	鍪 9381 91DE	鑿 93DB 96D7	鑿 943E 9A4F	铃 94C3 9AB8	门 95E8 8BEC	隼 96BD 90C7	靛 9789 90E6
躡 8E3A 99E3	輗 8EDA 9BD1	辭 8FA5 9050	迹 8FF9 905B	醜 915C 9FB0	鈎 91FE 8FD5	鈎 926B 99FB	銜 92E5 975B	鍪 9343 9A45	鍪 9384 9A46	鑿 93E0 9343	鑿 9442 FE40	铜 94DC 9AAE	间 95F4 9A56	霽 96F4 92E4	靛 979B 9650
踴 8E46 8A4A	輗 8EE2 99EB	震 8FB3 9054	迓 9008 9EDB	醜 915E 89AD	鈎 9208 9E73	鈎 926E 97E0	銜 92EB 9A41	鍪 9344 FA4B	鍪 9385 FEB0	鑿 93F0 FDCB	鑿 9443 FE43	银 94F6 9AA7	卩 961D 8BFB	霽 9703 9F52	靛 979F 90E7

韜 97B1 90E8	頓 9814 FCBC	颯 98C7 9144	餗 9938 9652	馱 99C5 9A6F	马 9A6C 89C6	鬪 9B2D 9161	鮠 9BB0 A067	鮓 9C26 8B56	鴉 9D39 91A7	鷄 9DC4 91A1	麇 9E96 A070	黏 9EC7 89B6	齡 9F62 91C8		
鞫 97B2 9A5D	頤 9815 8A74	颯 98C8 9143	餗 9939 914D	馱 99DA 9FAB	骏 9A8F 89C7	哺 9B34 9164	鮠 9BCF 96B3	弱 9C2F 9ADA	鴉 9D44 A05E	鷄 9DC9 89B8	麇 9E98 9F6D	駿 9EE2 9AAF	齒 9F69 91C9		
鞫 97B4 9F7A	頤 981F 9657	颯 98CA 9141	餗 993B 9666	馱 99E1 8EC1	馱 9AB2 8A6A	馱 9B39 9F41	鮠 9BDD 9A76	鰲 9C35 96B0	鴉 9D49 9A7D	鷄 9DD4 9173	麇 9E9E 91AC	騰 9EF1 9AB0	齿 9F7F 8DE6		
鞫 97B8 9B5C	頤 9823 9CEF	颯 98CE 8BF0	餗 9940 9F7B	馱 99E6 9555	馱 9AB6 8B57	馱 9B40 9169	鮠 9BE9 95D5	鰲 9C3A 9A7E	鴉 9D4E 8948	鷄 9DFC 9AA6	麇 9EA2 91AD	鹽 9EF8 9AB1	龐 9F8E 91CB		
鞫 97BA 9F7C	頤 982E 9DFD	颯 98DC 9660	餗 9942 9A6B	馱 99F5 9152	馱 9ABA 9FE1	馱 9B50 9168	鮠 9BED 9ECA	鰲 9C45 9DDE	鴉 9D50 9EB1	鷄 9E0A 89BD	麦 9EA6 A0FD	吊 9EFE 9AA1	龙 9F99 89C8		
鞫 97BD FC5D	頤 9833 90F7	飞 98DE 8BF1	餗 994A A06C	馱 9A0C 9153	馱 9ABD 9B5F	馱 9B69 9A74	鮠 9BF1 9A77	鰲 9C4F 96AD	鴉 9D5E 9DDB	鷄 9E0C 89B9	麇 9EA8 9FE2	鼉 9F02 91B9	龜 9F9C 8BF8		
鞫 97BE 90E9	頤 9834 90F6	食 98E0 99F6	饕 994D 9667	馱 9A10 9155	馱 9AD7 A05D	鈴 9B7F 96B2	鮠 9BF4 9A78	鰲 9C53 96AE	鴉 9D6D 95BF	鷄 9E0E 917D	麇 9EAA 91AF	鼉 9F08 91BA	龟 9F9F 8DAA		
鞫 97C0 90EA	頤 9847 9B5E	浪 98E1 9149	饕 995D 9A6C	馱 9A1F 955D	髡 9AE0 915B	鮠 9B81 9A75	鮠 9BFF 9170	鰲 9C5D 9EA1	鴉 9D6E 8A73	鷄 9E18 96BB	麇 9EAB 9E41	鼉 9F17 91BE	顛 9FA5 9FDD		
鞫 97C2 9A5E	頤 984B 90F8	飢 98E6 914A	饕 9962 9A6D	馱 9A21 9671	髡 9AE2 915C	鮠 9B83 FDA5	鮠 9C02 916F	鰲 9C72 9E50	鴉 9D7C 9EFE	鷄 9E1C 9FF2	麇 9EAC 9AAA	鼉 9F26 A041	” FF02 C8D0		
鞫 97C8 9F76	頤 9866 90F9	養 98EC 914B	𠂇 9963 8BF2	馱 9A26 9C6D	髡 9AF4 915E	鮠 9B8B 9EE9	鮠 9C0A 9FA3	鰲 9C7B 96AF	鴉 9D7E 917A	鸟 9E1F 8BF5	麇 9EAF 91B0	鼉 9F27 8BB7	’ FF07 C8CF		
鞫 97D2 90EB	頤 986C FA6A	殮 98F1 9A64	馱 999B 966A	馱 9A2F 9673	髡 9AFF 9F5C	鮠 9B8D 8BBA	鮠 9C0C 9171	鱼 9C7C 8BF4	駝 9D83 917B	鷄 9E7B 9AA9	麇 9EB1 9AAB	鼉 9F39 91C0	[FF3B C6E4		
鞫 97E0 90EC	页 9875 8BEF	飢 98F5 8ABF	馱 99A4 FCEA	馱 9A3B 9154	髡 9B02 9F57	鮠 9B8E 916D	鰲 9C10 96B1	鳩 9D02 9FA4	鷄 9D93 9AA3	鹿 9E81 9F54	麇 9EBD 9AAC	鼉 9F44 9AB3] FF3D C6E5		
韦 97E6 8BEE	颯 98B4 9FE0	餗 990E 9A66	馱 99AA 966C	馱 9A3C 9A71	鬚 9B09 9F65	鮠 9B8F A060	鰲 9C15 9F63	鴉 9D0C 96BD	鷄 9DA5 96C2	麓 9E84 9FE3	磨 9EBF 9A4A	鼉 9F45 91C3	┌ FFE2 C8CD		
韮 97EE 90EE	颯 98B7 9142	篩 9919 9A67	馱 99B8 91C4	贏 9A58 9156	鬚 9B0F 9A72	鮠 9B97 9FDE	鯁 9C1B 9F67	鴉 9D16 96F4	鷄 9DAB 9F77	麇 9E85 9EED	磨 9EC1 91B2	齐 9F50 A0FC	┌ FFE4 C8CE		
壘 97F2 91C6	颯 98B9 9A62	餗 991C 9A69	馱 99BC 9677	馱 9A5C 966D	鬚 9B14 9160	養 9B9D 9FC3	鰲 9C1F 8BB9	鷄 9D21 96B8	鷄 9DBD 9AA4	磨 9E90 91AA	黄 9EC4 8BF6	齒 9F53 9FEE	■ FFFE F9FE		
韵 97F5 90F2	颯 98C3 9569	餗 9937 9A6A	馱 99C4 99F4	馱 9A63 9557	鬚 9B2A 9F5E	鮠 9B9F 96B5	鰲 9C20 9A7A	鴉 9D34 FAA1	鷄 9DC0 9AA5	麇 9E95 91AB	鞫 9EC6 9AAD	齒 9F5A 9F69			

Table 3.4 – Code Table of the HKSCS outside the PUA of ISO 10646 v2.0

The following is an example of a typical cell in this table:

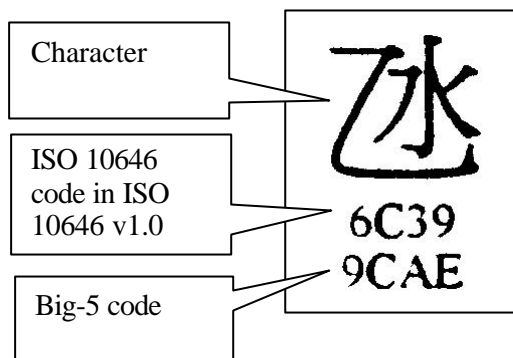

ˆ 00A8 C6D8	ō 00F3 8875	ū 016B 8878	ı 026A C8FE	К 041A C7FE	Ъ 042A C84F	к 043A C860	ъ 044A C870	iv 2173 C6B8	⑦ 2466 C6A7	┘ 2552 F9E6	┘ 2562 F9F4	ゝ 2E80 C8D6	𠄎 2EB6 C8E6	あ 3041 C6E7	け 3051 C6F7
À 00C0 8859	ø 00F8 C8FB	Ǻ 01CD 8858	ø 0275 C8F9	Л 041B C840	Ы 042B C850	л 043B C861	ы 044B C871	v 2174 C6B9	⑧ 2467 C6A8	┘ 2553 F9EF	┘ 2563 F9E2	㇇ 2E84 C8D7	月 2EBC C8E7	あ 3042 C6E8	げ 3052 C6F8
Á 00C1 8857	ù 00F9 887B	ǻ 01CE 8869	ſ 0283 C8F5	М 041C C841	Ь 042C C851	м 043C C862	ь 044C C872	vi 2175 C6BA	⑨ 2468 C6A9	┘ 2554 F9DD	┘ 2564 F9E7	冂 2E86 C8D8	卍 2EBE C8E8	い 3043 C6E9	こ 3053 C6F9
È 00C8 885D	ú 00FA 8879	ǿ 01D0 8872	ϋ 028A C8FD	Н 041D C842	Э 042D C852	н 043D C863	э 044D C873	vii 2176 C6BB	⑩ 2469 C6AA	┘ 2555 F9E8	┘ 2565 F9F0	凵 2E87 C8D9	角 2EC6 C8E9	い 3044 C6EA	ご 3054 C6FA
É 00C9 885B	ü 00FC 88A2	Ǿ 01D1 8860	ˆ 02C6 C6D9	О 041E C843	Ю 042E C853	о 043E C864	ю 044E C874	viii 2177 C6BC	(1) 2474 C6AB	┘ 2556 F9F1	┘ 2566 F9DE	ヶ 2E88 C8DA	𠄎 2ECA C8EA	う 3045 C6EB	さ 3055 C6FB
Ê 00CA 8866	Ā 0100 8886	ǿ 01D2 8876	Ë 0401 C7F9	П 041F C844	Я 042F C854	п 043F C865	я 044F C875	ix 2178 C6BD	(2) 2475 C6AC	┘ 2557 F9DF	┘ 2567 F9ED	ト 2E8A C8DB	し 2ECC C8EB	う 3046 C6EC	ざ 3056 C6FC
Ë 00D2 8861	ā 0101 8867	ǿ 01D4 887A	А 0410 C7F3	Р 0420 C845	а 0430 C855	р 0440 C866	ë 0451 C85B	x 2179 C6BE	(3) 2476 C6AD	┘ 2558 F9EC	┘ 2568 F9F6	ヾ 2E8C C8DC	し 2ECD C8EC	え 3047 C6ED	し 3057 C6FD
Ë 00D3 885F	Ē 0112 885A	ū 01D6 887C	Б 0411 C7F4	С 0421 C846	б 0431 C856	с 0441 C867	Ë 1EBE 8863	↖ 21B8 C877	(4) 2477 C6AE	┘ 2559 F9F5	┘ 2569 F9E4	ツ 2E8D C8DD	β 2ECF C8ED	え 3048 C6EE	じ 3058 C6FE
à 00E0 886A	ē 0113 886C	ü 01D8 887D	В 0412 C7F5	Т 0422 C847	в 0432 C857	т 0442 C868	ë 1EBF 88A4	↔ 21B9 C878	(5) 2478 C6AF	┘ 255A F9E3	┘ 256A F9EA	ヨ 2E95 C8DE	β 2ED6 C8EE	お 3049 C6EF	す 3059 C740
á 00E1 8868	Ë 011A 885C	ü 01DA 887E	Г 0413 C7F6	У 0423 C848	г 0433 C858	у 0443 C869	Ë 1EC0 8865	↑ 21E7 C876	(6) 2479 C6B0	┘ 255B F9EE	┘ 256B F9F3	𠄎 2E9C C8DF	𠄎 2ED7 C8EF	お 304A C6F0	ず 305A C741
è 00E8 886F	ë 011B 886E	ü 01DC 88A1	Д 0414 C7F7	Ф 0424 C849	д 0434 C859	ф 0444 C86A	è 1EC1 88A6	① 2460 C6A1	(7) 247A C6B1	┘ 255C F9F7	┘ 256C F9E1	月 2E9D C8E0	倉 2EDE C8F0	か 304B C6F1	せ 305B C742
é 00E9 886D	ī 012B 8870	ɸ 0250 C8F6	Е 0415 C7F8	Х 0425 C84A	е 0435 C85A	х 0445 C86B	No. 2116 C8D2	② 2461 C6A2	(8) 247B C6B2	┘ 255D F9E5	┘ 256D F9FA	𠄎 2EA5 C8E1	骨 2EE3 C8F1	が 304C C6F2	ぜ 305C C743
ê 00EA 88A7	η 014B C8FC	ɑ 0251 886B	Ж 0416 C7FA	Ц 0426 C84B	ж 0436 C85C	ц 0446 C86C	Tel 2121 C8D3	③ 2462 C6A3	(9) 247C C6B3	┘ 255E F9E9	┘ 256E F9FB	生 2EA7 C8E2	么 2F33 C6CD	き 304D C6F3	そ 305D C744
ì 00EC 8873	Ō 014C 885E	о 0254 C8F8	З 0417 C7FB	Ч 0427 C84C	з 0437 C85D	ч 0447 C86D	i 2170 C6B5	④ 2463 C6A4	(10) 247D C6B4	┘ 255F F9F2	┘ 256F F9FD	正 2EAA C8E3	々 3005 C6E0	ぎ 304E C6F4	ぞ 305E C745
í 00ED 8871	ō 014D 8874	ε 025B C8F7	И 0418 C7FC	Ш 0428 C84D	и 0438 C85E	ш 0448 C86E	ii 2171 C6B6	⑤ 2464 C6A5	— 2550 F9F9	┘ 2560 F9E0	┘ 2570 F9FC	𠄎 2EAC C8E4	𠄎 3006 C6E1	く 304F C6F5	た 305F C746
ò 00F2 8877	æ 0153 C8FA	g 0261 88A8	Й 0419 C7FD	Щ 0429 C84E	й 0439 C85F	щ 0449 C86F	iii 2172 C6B7	⑥ 2465 C6A6	 2551 F9F8	┘ 2561 F9EB	* 273D C6E6	𠄎 2EAE C8E5	○ 3007 C6E2	ぐ 3050 C6F6	だ 3060 C747

ち 3061 C748	ば 3071 C758	め 3081 C768	ゑ 3091 C778	オ 30AA C7A6	ズ 30BA C7B6	ナ 30CA C7C6	へ 30DA C7D6	リ 30EA C7E6	(株) 3231 C8D1	劇 34DF 9E53	啞 35A1 FB7A	啞 35FB 8AEB	競 3681 89EF	娣 36D3 935B	嫫 3723 91F9
ぢ 3062 C749	ひ 3072 C759	も 3082 C769	を 3092 C779	カ 30AB C7A7	セ 30BB C7B7	ニ 30CB C7C7	ホ 30DB C7D7	ル 30EB C7E7	仔 3435 9277	刮 34E4 9DAA	啞 35A5 89FB	嘸 35FE 9FD7	吝 369A 96E9	蜂 36D4 95C7	嬭 3725 8FF1
っ 3063 C74A	び 3073 C75A	や 3083 C76A	ん 3093 C77A	ガ 30AC C7A8	ゼ 30BC C7B8	ヌ 30CC C7C8	ボ 30DC C7D8	レ 30EC C7E8	伏 3440 96DF	罰 34FB 9BEA	啞 35AD 9EFC	啞 3609 8B6A	奸 36A5 9EBB	媵 36D6 97E7	嬭 372C 9745
つ 3064 C74B	び 3074 C75B	や 3084 C76B	ゝ 309B C8D4	キ 30AD C7A9	ソ 30BD C7B9	ネ 30CD C7C9	ポ 30DD C7D9	ロ 30ED C7E9	匡 344C 89D5	齧 3506 8A6E	啞 35BF 89FC	啞 3618 9C5C	媵 36AA 94DE	媵 36DD 9359	嬭 372D 9853
づ 3065 C74C	ふ 3075 C75C	ゆ 3085 C76C	ゝ 309C C8D5	ギ 30AE C7AA	ゾ 30BE C7BA	ノ 30CE C7CA	マ 30DE C7DA	ワ 30EE C7EA	借 3464 93CD	巳 353E 8BC8	啞 35C1 89BF	啞 361A 8BB1	媵 36AC 9EB8	媵 36E1 91F5	嬭 3730 FE78
て 3066 C74D	ぶ 3076 C75D	ゆ 3086 C76D	ゝ 309D C6DC	ク 30AF C7AB	タ 30BF C7BB	ハ 30CF C7CB	ミ 30DF C7DB	ワ 30EF C7EB	傷 3473 9BDF	厨 3551 89E8	啞 35C5 89FE	圓 3623 FB5E	媵 36B0 97BA	媵 36E2 97B8	嬭 3732 FBC1
で 3067 C74E	ふ 3077 C75E	よ 3087 C76E	ゝ 309E C6DD	グ 30B0 C7AC	ダ 30C0 C7BC	バ 30D0 C7CC	ム 30E0 C7DC	卍 30F0 C7EC	傷 347A FA68	屨 3553 89EA	啞 35C7 89E6	均 362D 9DF3	媵 36B1 FB65	媵 36E5 FDA2	嬭 3733 9251
と 3068 C74F	へ 3078 C75F	よ 3088 C76F	ア 30A1 C77B	ケ 30B1 C7AD	チ 30C1 C7BD	パ 30D1 C7CD	メ 30E1 C7DD	エ 30F1 C7ED	僮 347D 89DA	叡 3561 FB70	品 35CA 9D46	埶 3635 A0D0	媵 36B5 95D6	媵 36E6 FBB6	嬭 373A 9DAD
ど 3069 C750	べ 3079 C760	ら 3089 C770	ア 30A2 C77C	ゲ 30B2 C7AE	ヂ 30C2 C7BE	ヒ 30D2 C7CE	モ 30E2 C7DE	ヲ 30F2 C7EE	僮 347E 8F59	吠 356D 89ED	啞 35CE 9DEE	些 3639 FC66	媵 36B9 9CBB	媵 36F5 92FA	嬭 3740 FD6C
な 306A C751	ぺ 307A C761	り 308A C771	イ 30A3 C77D	コ 30B3 C7AF	ツ 30C3 C7BF	ビ 30D3 C7CF	ヤ 30E3 C7DF	ン 30F3 C7EF	僮 3493 89DB	吒 3570 94DD	啞 35D2 A07E	埶 363E 92E9	媵 36BC 97DA	媵 3701 9357	嬭 3743 FA6B
に 306B C752	ほ 307B C762	る 308B C772	イ 30A4 C77E	ゴ 30B4 C7B0	ツ 30C4 C7C0	ピ 30D4 C7D0	ヤ 30E4 C7E0	ヴ 30F4 C7F0	僮 3496 8F5D	味 3572 89EE	啞 35D6 A068	塚 3647 9AEC	媵 36C1 8F45	媵 3703 8BA6	寓 3762 9BC2
ぬ 306C C753	ぼ 307C C763	れ 308C C773	ウ 30A5 C7A1	サ 30B5 C7B1	ヅ 30C5 C7C1	フ 30D5 C7D1	ユ 30E5 C7E1	カ 30F5 C7F1	豊 34A5 89DC	啞 3577 9EB4	啞 35DB 98E9	埶 3648 8FAB	媵 36C3 FB7D	媵 3708 FBB9	審 376F 9A7B
ね 306D C754	ぼ 307D C764	ろ 308D C774	ウ 30A6 C7A2	ザ 30B6 C7B2	テ 30C6 C7C2	ブ 30D6 C7D2	ユ 30E6 C7E2	ケ 30F6 C7F2	輝 34AF 96F7	啞 3578 8AD3	啞 35DD 8B68	埶 3649 FA48	媵 36C4 9158	媵 370A 97B0	尿 3797 8B60
の 306E C755	ま 307E C765	わ 308E C775	エ 30A7 C7A3	シ 30B7 C7B3	デ 30C7 C7C3	プ 30D7 C7D3	ヨ 30E7 C7E3	一 30FC C6E3	菡 34BC 8ADA	啞 3584 92DB	啞 35F1 8DFD	城 364E 8E45	媵 36C5 FE64	媵 370D FDC4	屨 37A0 934B
は 306F C756	み 307F C766	わ 308F C776	エ 30A8 C7A4	ジ 30B8 C7B4	ト 30C8 C7C4	ヘ 30D8 C7D4	ヨ 30E8 C7E4	ヽ 30FD C6DA	冗 34C1 8BDC	啞 3597 94DB	啞 35F2 8BBE	埶 365F 9C6F	媵 36C7 9856	媵 371C 9CA1	呵 37B9 9ABD
ば 3070 C757	む 3080 C767	る 3090 C777	オ 30A9 C7A5	ス 30B9 C7B5	ド 30C9 C7C5	ベ 30D9 C7D5	ラ 30E9 C7E5	ヾ 30FE C6DB	冫 34C8 97DB	啞 3598 89F9	啞 35F3 9FD9	埶 367A 9EDE	媵 36C8 9B4D	媵 3722 91F2	呢 37BE 91B7

嶮 37F2 95B4	怗 3914 8D6E	捫 39E2 955A	携 3A57 FCC4	瞽 3B2B FCEE	菴 3BC4 93E9	沓 3CEB FDA3	澗 3D7D 96A6	燿 3DE8 FDE9	罍 3EB1 9464	璦 3EE9 975D	痂 3F7C 98D6	瞿 4065 A0AC	稭 416C 90C0	糗 428C 9959	睇 43F2 9D4F
嶼 37F8 FEC5	怛 3927 96A8	抚 39E5 91B4	搯 3A5C A078	睜 3B39 997B	欄 3BD7 93F6	淬 3CEF 8DDB	濲 3D85 FBBF	熒 3DEB 9DB5	罍 3EB8 936F	璉 3EEB 91E3	瘡 3F93 8AF0	晰 406A 98EB	稭 416E 94D1	糗 4294 995B	豚 4401 997A
暫 37FB 9EF0	恣 3932 FCA6	孳 39EC 8A48	揲 3A5E 94B5	杪 3B42 8DB4	櫟 3BDD 8DC5	湑 3D13 8EAF	灑 3D8A 8DF3	熨 3DF3 9879	珉 3EBF 94B9	璿 3EF0 98CC	癩 3FC0 98D9	矚 406F 98EC	穉 417F 9573	紉 42B5 FA45	豚 4402 9564
嶸 380F 8D64	恹 393F 8D6F	捫 39F8 8D7D	携 3A66 FCC2	桤 3B58 8DB7	菴 3BEC 8DCA	梨 3D1D 91B5	灑 3D8F 9449	熨 3DF7 9D5D	璘 3EC2 95EC	璿 3EF3 9469	癩 3FD7 98DB	斫 40A8 98F4	秦秦 4190 95C2	紉 42B9 90B7	頤 4413 99A1
嶸 3819 9269	惧 394D 8D70	掬 39FB 8A7D	撮 3A67 8A6B	桤 3B60 91B3	櫟 3BF2 8DCC	漉 3D32 FD49	灑 3D91 8DF5	熨 3DFC 8D63	琤 3EC7 91EE	璿 3EF4 98CD	癩 3FDC 98DD	硤 40BB 8AB8	窳 41B2 9948	紉 42BC 9743	豚 4425 99A5
嶸 3820 8D67	恹 3963 FC64	捫 39FE 8AC2	敲 3A97 8DAB	榧 3B71 8DBB	櫟 3BF3 FD5D	澍 3D3B FDD1	烜 3DA5 9872	熨 3DFD 9669	琬 3ECA 98C3	歷 3EFA 98CE	睽 3FE5 98A8	碯 40FB 9EE7	竝 41C4 994B	綵 42F4 95CD	膾 442D 99A7
玨 382D FBEA	恹 3980 9060	揲 3A01 FD4A	敲 3AAB FAE8	裕 3B72 8DBA	榕 3BF4 93B5	澗 3D46 8DEB	烜 3DAD 8E6B	熨 3E06 9F70	琮 3ECC 95F6	璿 3EFC 95FC	破 3FED 8A6D	碯 40C8 94BC	竝 41CA 8E55	綵 42FB 97C9	颯 447A 8EED
帆 3836 FBF5	愷 3989 8D74	捫 3A03 8DA1	昕 3ABD 8DAD	梢 3B7B 8DBC	隼 3C0D FD61	漉 3D4C 97C6	烜 3DB4 FAFD	特 3E40 FC6A	琬 3ED0 8FFD	璿 3EFF 94A3	燧 3FF9 8AFB	磴 40D8 FCD1	醇 41CF 994E	縕 42FC FD50	艷 448F 99AD
帙 3838 8D68	懔 398A 97C3	捫 3A06 8AD1	眈 3ADE FC49	楷 3B7C 9044	櫟 3C11 9CF8	澗 3D4E FDCE	焯 3DBF 8F50	隼 3E43 8AC7	琬 3ED1 98C5	璿 3F00 9662	燧 3FFA 8AAE	碯 40DF 9CC6	筮 41DB 8EFE	纜 432B 8EB9	苻 449F 946E
龍 3863 93EB	愕 3992 8AD0	捷 3A17 FCB4	畔 3AE0 93C1	楸 3B80 FD4C	穰 3C15 9252	澗 3D51 90FC	焯 3DC6 9DCC	隼 3E48 89D7	琬 3ED6 9766	璿 3F04 FEB6	盜 4004 FBC9	礪 40FA 9E7E	筮 41EF 8E59	挑 436E 95C6	苻 44A0 8F70
廻 38A0 FC42	悞 3999 9274	揲 3A18 8B47	眈 3AF0 906F	榫 3B96 93E4	些 3C54 9CA5	澗 3D5F FC59	焯 3DC7 FC65	隼 3E55 FE4D	琬 3ED7 FE6E	璿 3F06 9463	眈 401D 98E4	袂 4103 98FE	箬 41F9 94EC	翻 4397 9967	茆 44A2 FAD0
彌 38C3 9166	舉 399B 9BBE	捫 3A29 93A4	眈 3AF2 8DB0	桤 3B99 93E0	沂 3CCB 8DD6	潘 3D62 96D6	焯 3DCC 996E	狃 3E74 9EDD	珊 3EDA 97DD	燄 3F0E 98D0	眈 4039 98E6	裋 4104 FDE8	篙 4211 94EF	瞞 43BA 8AB9	莖 44B0 99B3
邕 38CC FACD	懔 39A1 9CC8	揲 3A2A 9EDA	論 3AFB 947E	渠 3BA1 FD53	沛 3CCD 97C0	灑 3D69 97C5	焯 3DCD 94A1	玨 3EA8 FEFB	璿 3EDE 92D2	璿 3F53 98D1	眈 4045 98E8	袂 4109 9940	箬 4240 8F74	睇 43C1 8DFC	苦 44B7 A053
彪 38D1 93DD	懔 39A4 9CBA	揲 3A34 8A51	焯 3B0E 90FA	榫 3BBC 8DC3	泗 3CD1 A0DE	灑 3D6A 8DEF	焯 3DD3 8F63	玨 3EA9 98BC	璿 3EE1 9761	眈 3F58 9475	睽 4053 8A4D	袴 410E 94C9	箬 4260 9955	眈 43D9 8A76	苦 44C0 965C
小 38FA 8BCC	戟 39B8 8D78	搯 3A4B 8DA6	眈 3B19 9479	渠 3BBE 9BB8	浓 3CD6 97D2	灑 3D6F 97D7	保 3DDB A0DA	玨 3EAA FACC	璿 3EE2 98CB	眈 3F59 FAE0	眈 4057 9257	衲 4132 94D3	篙 426A 9544	眈 43DF 9D51	苻 44C5 FD7A
怵 3908 8D6D	捫 39DC 9EB9	揲 3A52 9EC5	曦 3B22 8DB2	櫛 3BC2 FBF0	淋 3CDC FAA5	灑 3D75 8DF0	焯 3DE7 9253	玨 3EAD 95B0	璿 3EE7 95F0	眈 3F63 9472	眈 4062 95DF	稽 4167 9946	紅 427A 9956	眈 43ED 9973	葯 44CE 97FE

蓋 44DD 92BD	蕪 4533 96C8	衍 4615 8FEB	昨 47ED 99E1	醜 4911 89C5	閱 49A7 9A55	饒 4B37 FCCF	髻 4C07 A06A	黏 4D34 91AE	乚 4E5A C87B	从 4ECE 9FCF	佻 4F8A 926F	倅 5034 9163	儁 5101 FA67	富 51A8 92BA	九 51E2 FAA9
萇 44DF 97FD	藪 453B 99C3	衛 4617 99CF	賑 47F4 8A67	鈇 491E 99F8	陷 49DF 90BC	甜 4B6F 966B	鬢 4C0E 915F	髻 4D91 9D78	丿 4E5B 8BC6	儀 4EEA 9DA9	偁 4FA2 92A3	偕 5056 9F73	儂 510D 92A2	彳 51AB C6C5	夙 51E4 8954
葱 44E4 8F64	蕩 453D 90D6	襖 465B 8FC2	踔 4800 8BB5	銳 4925 9664	隄 49E5 9A58	醇 4B70 9A6E	斂 4C3B 9FA5	齧 4D9C 9D7B	凵 4E6A 9C57	佻 4EEB 89D3	侨 4FA8 8950	侶 5058 92AD	儼 510E FA69	冲 51B2 FA7D	凭 51ED FAAB
稜 44E9 FCF7	葦 453F 9CBE	煇 467A 92C9	踔 480B 8AAC	錄 492A 9055	儀 49E7 8BB8	裔 4B72 914F	鮑 4C3E 89BA	丄 4E04 9EB3	媯 4E78 9AFB	佞 4EEE 99E2	佞 4FAB FA57	偁 5066 9BE9	儂 512B 9268	決 51B3 FAA8	憑 51F4 FC7A
葛 44EA 9562	蔭 4543 8F76	靦 4680 97DC	眺 4837 99E9	銑 492D 96D4	霰 4A0F 90D5	駢 4B7B 9746	鮫 4C5B 9ECD	业 4E1A 9EB2	龜 4E80 89D0	佻 4EF8 9267	偁 4FB0 9866	偁 506C 92A9	兗 5156 8951	冚 51B4 9A68	囿 51FC 89E0
萸 44EB 97CD	葳 4551 9470	詭 46CF 95B3	輓 485D FBCA	銑 4935 977C	霄 4A1D 9641	駢 4B7E A0E6	鮫 4C6D 9A79	东 4E1C 9DD6	乾 4E81 89CF	仔 4F03 92A4	偁 4FBD 89D6	偁 5081 92AA	兗 5160 FA6F	况 51B5 FA47	囿 51FE 9F4F
葦 44EC 9E64	藟 4552 FB4B	詭 46D0 9C79	輻 4871 97DE	錄 493C 964D	霰 4A24 9A5A	駢 4B8E 92D7	鮫 4C7D 9DCE	冫 4E21 994F	会 4E85 C6C1	会 4F1A 894E	偁 4FC8 98B2	偁 5088 89D9	兗 516A FA71	泮 51B8 FA7E	冫 5202 C87D
萸 44F4 924C	藟 4555 FDCA	詭 46F5 95B2	週 489B 95D1	鎔 493E 97E1	霰 4A35 9A5C	駢 4B90 9675	鮫 4CA4 9D73	冫 4E24 89CE	冫 4E87 89D1	佻 4F28 894F	偁 4FCC 92AB	偁 5090 FD56	兴 5174 8952	涂 51C3 92BB	办 5205 89E1
菹 4503 8EC9	藟 455C 8EC7	諛 4713 8FDB	遠 48AD 99F5	璽 4945 9A48	靺 4A96 97C2	駢 4B93 93D4	鴉 4CAE 96B9	冫 4E28 8BC0	争 4E89 89E2	仗 4F29 9278	偁 4FE4 96DE	偁 50A6 9FA8	兹 5179 945A	淞 51C7 FDB6	刊 520B FAB0
蓄 4504 99BC	藟 4562 A0F9	諛 4718 9BE3	逋 48AE FC4A	鏤 4951 9A49	頰 4AB4 8ABB	駢 4B96 91BB	鴉 4CB0 96BC	个 4E2A 9FC4	亘 4E98 927E	佻 4F32 91B6	偁 4FE5 92AC	偁 50CD 92A1	冫 5182 C6C3	凉 51C9 FAA2	刮 521F 9FCD
菹 4509 9DA5	藟 456A 8FA9	獯 474E 9E7A	鄭 48D0 9BA9	鏤 4953 FE7D	頰 4AB8 9BAA	駢 4B97 9679	鴉 4CB7 9CD1	斗 4E2C 8BD4	亚 4E9A 9DBA	佻 4F37 89D4	偁 4FF2 9F6E	偁 50D0 90E3	冫 5186 89DD	減 51CF FAA3	刪 5220 A0E7
紗 450B 8F54	藟 4577 99C7	賄 477C 9BEE	郟 48DD FBDC	鏤 4965 90AA	頰 4AD1 90F5	駢 4B9D 9A70	鴉 4CCD 89B7	丩 4E36 C6BF	一 4EA0 C6C2	但 4F39 9FD2	偁 4FF9 8EF2	偁 50D9 A0A6	冫 5188 C8A2	湊 51D1 FAA4	刮 5226 FAB1
陵 4516 8F7C	藟 4585 90D7	赳 4798 99DE	猷 48ED FE56	鏤 496A 9A50	頰 4AE4 9A60	驪 4BBD 9678	鴉 4CE1 9EEE	冫 4E37 8BF9	廉 4EB7 FBF8	征 4F42 92A7	偁 4FFD 9F6C	偁 50DF 94AB	冫 5196 C6C4	澧 51D2 9BB4	劫 5227 89A6
紫 451D 8EA2	蠟 45E9 9EDF	赳 47A6 FAFA	酏 48F3 9EA4	鏤 4972 9347	颯 4AFF 9145	驪 4BBE 91CD	鴉 4CED FB43	丽 4E3D 8946	亻 4EBB 8BC7	佻 4F45 95A2	偁 5003 89D8	偁 50E1 FC72	冫 519A 9E52	凜 51D3 FAA6	剝 5234 9EFA
藟 4527 8F7A	蠟 4606 99CE	赳 47B6 9EE5	酏 48FA 9D49	颯 4989 8ED8	颯 4B19 9A63	驪 4BC0 9C4A	鴉 4D09 9EC9	丩 4E3F C6C0	亻 4EBC 926B	佻 4F4B 926E	偁 5008 FA59	偁 50F4 97C4	农 519C 8953	凜 51DB 89DF	劫 523C FAB2
蕪 452E 97AE	郵 460F 8FBA	跂 47D5 8A52	醜 4906 95DB	閻 49A1 90C9	缺 4B2C 8BB6	鬚 4C04 A06F	鸚 4D10 FBD3	义 4E49 FAE5	亿 4EBF 89D2	佻 4F72 96EA	偁 502E 92A8	偁 50FC 92AE	冫 51A7 9E55	瀆 51DF FDDB	剝 5257 FAB4

𪗇 5259 92C4	勗 52D0 FBC4	鹵 5364 9AF1	𪗈 53B0 89E9	吓 5413 FAEF	𪗉 5494 9E47	𪗊 5502 97A7	𪗋 5571 95DA	𪗌 55EA 9DE9	𪗍 5643 9DEB	𪗎 569F 91C1	𪗏 5732 94A7	𪗐 5790 FC67	𪗑 5803 FB69	𪗒 58A7 9EE6	备 5907 895E
𪗓 5260 9F6F	勗 52D1 9F71	卧 5367 9EB7	厶 53B6 C6C9	𪗔 5414 96EF	𪗕 5497 9DF7	𪗖 550D 93BA	𪗗 5572 9DF8	𪗘 55EC 8F52	𪗙 564D FB54	𪗚 56A1 8AC5	𪗛 573F 9BD4	𪗜 579C 8B7D	𪗝 5812 97E5	𪗞 58AA FB6F	𪗟 590A C6CA
割 5268 8BB0	勗 52E0 FABA	𪗟 5369 C6C8	叁 53C1 FAE2	𪗡 5416 9DEC	𪗢 549C 9FD3	𪗣 5513 9E58	𪗤 5573 9F6A	𪗥 55F0 9DF5	𪗦 564F FB55	𪗧 56A4 97A3	𪗨 5742 FB64	𪗩 57A1 9BF4	𪗪 5822 967D	𪗫 58B0 8EE1	𪗬 5911 FE42
割 5273 9FAC	勗 52E1 92C7	𪗭 536D FAD1	叁 53C2 89EB	𪗯 541A 9DCA	𪗰 549E 9ACA	𪗱 5518 89F6	𪗲 5579 8AB7	𪗳 55F1 9DF0	𪗴 5650 9AA2	𪗵 56AF 8B6C	𪗶 5743 FB76	𪗷 57A7 9EF7	𪗸 5826 FB6C	𪗹 58B5 9B7D	𪗺 591F FB7B
𪗻 5279 89E3	𪗼 52F9 C6C6	𪗽 5374 FAD2	𪗾 53C5 FAE3	𪗿 5421 FD6D	𪗠 54A3 89F1	𪗡 551E 9E57	𪗢 5586 FB46	𪗣 55F5 99E7	𪗤 5652 8AD6	𪗥 56B1 8D7E	𪗦 5746 FB60	𪗧 57AA 9EC1	𪗨 583A 99A2	𪗩 58B6 9C7E	𪗪 5932 895F
𪗫 528F 9BD3	𪗬 5301 9A4C	𪗭 537D 9EBA	𪗮 53CC 90C8	𪗯 5423 89EC	𪗰 54A4 FAF9	𪗱 5523 89F7	𪗲 5590 8A46	𪗳 55FB 8BBD	𪗴 5654 9A5F	𪗵 56B9 9C54	𪗶 5754 99E5	𪗷 57B4 996F	𪗸 5840 9ABB	𪗹 58BB F9D9	𪗺 5934 8960
𪗻 5290 89E4	𪗼 5327 89E5	𪗽 537E FAD4	𪗾 53D0 92DA	𪗿 542F FB44	𪗠 54B2 8E5A	𪗡 5525 8A41	𪗢 55A9 FB47	𪗣 5605 9DEF	𪗤 565D 9EF5	𪗥 56BF 9DBD	𪗦 5757 9AC2	𪗧 57BB 96F1	𪗨 5844 9A65	𪗩 58CB 92EA	𪗪 5965 9BCD
𪗫 5294 FAB5	𪗬 532C 9F7D	𪗭 5393 FAD9	𪗮 53D1 8959	𪗯 5432 9DE2	𪗰 54B4 89F2	𪗱 5528 89F8	𪗲 55B0 9148	𪗳 5611 9FB7	𪗴 5661 8FB7	𪗵 56D6 9CC5	𪗶 575B 91FB	𪗷 57BE 8E41	𪗸 5847 944E	𪗹 58DC FB72	𪗺 5975 9DD3
𪗻 529A 9FD5	𪗼 5332 A0A9	𪗽 53A0 FADB	𪗾 53D2 9CF5	𪗿 544B 9EC0	𪗠 54B9 89F3	𪗡 552B FAF1	𪗢 55B4 92DE	𪗣 561E 9DD0	𪗤 567A 9AD2	𪗥 56E2 895B	𪗦 575F A073	𪗧 57C4 954A	𪗨 585C FB6E	𪗩 58E0 FB71	𪗪 5989 984C
𪗻 52A1 8955	𪗼 5333 FAC4	𪗽 53A2 9CE0	𪗾 53D8 895A	𪗿 544D 9E56	𪗠 54CB 925D	𪗱 553F 89FA	𪗲 55B9 8B53	𪗳 5620 9FEB	𪗴 567B 9E6A	𪗵 56ED FB5C	𪗶 5767 9F72	𪗷 57C8 97E6	𪗸 585F 99DF	𪗹 58F0 895C	𪗺 5994 9752
𪗻 52A4 92C5	𪗼 5338 C6C7	𪗽 53A6 FBF7	𪗾 53D9 FAE7	𪗿 5469 9F79	𪗠 54CC 8B51	𪗱 5547 FB42	𪗲 55BA 9DF6	𪗳 5621 8DA9	𪗴 567C 9EE8	𪗵 56EF FB5B	𪗶 577A 9FCC	𪗷 57D7 96F5	𪗸 5869 98E3	𪗹 58F2 98F0	𪗺 599A 95C3
𪗻 52A8 8956	𪗼 533B 8957	𪗽 53A8 FBFA	𪗾 53DA 9FA2	𪗿 546A 9AC7	𪗠 54CD 92E0	𪗱 5549 FABF	𪗲 55BC 9BDA	𪗳 5622 9DCF	𪗴 5689 8BBF	𪗵 56F1 FB57	𪗶 577E 98A5	𪗷 57DD 92E6	𪗸 586C 9254	𪗹 58F3 96F2	𪗺 599F 9BB6
𪗻 52B5 FAB3	𪗼 5342 FAAA	𪗽 53A9 89E7	𪗾 53E0 FAEA	𪗿 546D FAF4	𪗠 54D0 89F4	𪗱 5553 FBA3	𪗲 55C1 9D7E	𪗳 5623 98E1	𪗴 568A 91C2	𪗵 56FD 98C7	𪗶 577F 92E8	𪗷 57DE 9F42	𪗸 5872 967B	𪗹 58FB FB74	𪗺 59AC 9AB9
𪗻 52B9 FAB6	𪗼 534E 8958	𪗽 53AA A07A	𪗾 53F6 FAED	𪗿 5485 98A1	𪗠 54DA 9FD4	𪗱 555D FAF7	𪗲 55D7 89FD	𪗳 5625 9DE5	𪗴 568B 9D62	𪗵 5700 FB5A	𪗶 5788 9BBC	𪗷 57E6 FB67	𪗸 5873 8AAF	𪗹 5902 8BC1	𪗺 59B0 97B3
𪗻 52C5 FAB7	𪗼 535D 8BE3	𪗽 53AB FADC	𪗾 53F7 8FAD	𪗿 548F FAF8	𪗠 54E3 8A79	𪗱 5569 9E4E	𪗲 55D8 99E4	𪗳 562D 9DC8	𪗴 5692 9260	𪗵 5715 9CEE	𪗶 578A 96F3	𪗷 57EF 99A9	𪗸 5899 8BAF	𪗹 5904 895D	𪗺 59B7 9F74
𪗻 52CC 9EDC	𪗼 535F 8B61	𪗽 53AE FADD	𪗾 53FE FB59	𪗿 5493 89F0	𪗠 54EF 89F5	𪗱 556B 94DC	𪗲 55DE 9E43	𪗳 5637 FB4F	𪗴 569E 925E	𪗵 571D 92E2	𪗶 578D 92E7	𪗷 57FE FAE6	𪗸 589A 9EBD	𪗹 5905 89DE	𪗺 59B8 92F1

媿 59C4 97DF	媿 5A2B 985C	媿 5A86 9572	媿 5AFE 9672	宀 5B80 C6CB	奈 5C1E 934C	崢 5CE5 8D73	崢 5D85 9CEB	嶰 5E48 934F	弑 5F0E 9362	亅 5FC4 8BCB	愀 60DE FD64	愀 6164 FC74	愀 61E2 A079	拥 62E5 8D7B	掬 63E6 9DA4
姊 59C9 FBA6	斌 5A2C 92F0	嫵 5A88 FDEF	媿 5B0D 9EB5	宀 5B82 FA79	尪 5C20 9AE2	崢 5CE9 FBDE	崢 5D8B FBE0	嶰 5E5E 934E	弑 5F25 8D6B	帆 5FDB 936E	愀 60E3 99BA	傷 616F A074	戩 622C 8D79	撈 6318 8D7C	揸 63F8 FCB6
姪 59D9 FBAB	嫵 5A3D 944C	媿 5A91 FDC1	媿 5B11 964B	宀 5B90 9E67	尪 5C23 8BC9	崢 5CEF FBDF	崢 5D8E 9F51	嶰 5E7A FBF4	强 5F3A FC4C	攸 5FDF FCD5	惧 60E7 9AD0	憾 617D A071	户 6237 8BFC	梯 632E 9ED6	撼 63FB 8DA3
姪 59EB 9877	嫵 5A45 916B	媿 5A96 FBBA	媿 5B1F A0FA	宝 5B9D FBD2	屮 5C49 FBDB	崢 5D10 FBE3	崢 5DA4 8D65	广 5E7F C6CE	彊 5F4D 95B8	恚 6023 FCA9	惨 60E8 9A61	憾 6181 FC79	戾 6239 A076	抄 6331 93AC	揸 63FC 9E4B
媿 59EF 9854	婁 5A54 8B78	媿 5A99 92EB	媿 5B2B 9575	实 5B9E 8962	屮 5C4A 9FC9	崢 5D15 8DA8	崢 5DAB 9CF1	广 5E83 FBC3	彊 5F50 C6D0	忽 6031 FC61	愀 60E9 A0E5	憾 6187 FC7C	扌 624C 8BCD	揸 6335 9F5B	揸 63FE 9E4D
媿 59F0 95C5	媿 5A59 94E2	媿 5AA0 FC73	媿 5B41 90DA	实 5B9F 8963	屮 5C53 9F44	崢 5D18 FBE4	崢 5DB6 FC58	庆 5E86 8965	彊 5F51 8BCA	总 603B 8966	愀 60FD A05B	愀 6195 9C50	扌 6268 9F5A	揸 6337 93A9	揸 6407 8DA4
妍 59F8 9D55	嫵 5A61 984F	媿 5AA1 97B7	媿 5B44 9367	宀 5BAA FC7D	屮 5C5E 98ED	崢 5D2C 9C75	崢 5DB9 8D66	厩 5EBD 8D6A	彊 5F5C 987A	協 604A FACB	愀 6107 96AC	愀 6198 9379	狂 6282 9FF4	揸 6364 A07C	揸 6432 8AFD
媿 59F9 FBB2	媿 5A63 FBB5	媿 5AAB FBB4	媿 5B46 FEA4	冤 5BC3 9F6B	屮 5C85 FBDD	崢 5D2F 9878	崢 5DC1 9634	廊 5ECD 9353	彊 5F61 C6D1	恒 6052 F9DA	愀 610C 9740	愀 6199 9378	拘 6285 9FBA	揸 636C FCB2	揸 6438 FCB5
媿 5A02 957E	媿 5A68 9271	媿 5AC3 90A7	媿 5B4A 90DF	寧 5BD5 FBCC	舄 5C99 8DF2	崢 5D3E 8D60	崢 5DD7 FBE8	廐 5ED0 9DFB	彊 5F63 FC51	惠 6075 937A	愀 6119 9EF1	愀 619C A0DD	扌 6290 8D7A	揸 6379 8AC1	携 643A FCC3
媿 5A0B 9742	媿 5A6B 9365	媿 5ACE 9741	媿 5B4F 9354	甯 5BD7 FEAE	崢 5C9A 8964	崢 5D46 FBE5	崢 5DDB C6CC	彊 5EF4 FBFD	彊 5F72 FC54	愀 6077 A0E0	愀 6130 9F7E	愀 61B7 8D75	拘 629D 9E45	揸 637F 9FB4	揸 643B 93B2
媿 5A0D 94E6	媿 5A6E 985B	媿 5ACF 92F4	学 5B66 8961	寶 5BF3 FBD1	崢 5C9C FDF2	媿 5D48 8D61	崢 5DF5 9FCE	廐 5EF8 9059	彻 5F7B FAAF	忙 607E 936B	博 613D 8D72	懷 61B9 8D76	护 62A4 93B0	揸 638B FCAC	揸 645A 8DA5
媿 5A12 92F5	媿 5A71 9850	媿 5AD3 FBBC	弄 5B68 8BB4	寿 5BFF FB75	咋 5C9E 934D	崢 5D56 8D62	崢 5E09 FBFC	迫 5EF9 FC40	徃 5F83 8D6C	悞 609E FC6B	悞 6142 FC76	悞 61C0 9374	扌 62A6 A075	揸 63B9 9E4C	揸 6471 93A1
媿 5A21 92FD	媿 5A79 97BC	媿 5AE4 9577	預 5B6D 9DC0	尪 5C05 FBD4	崢 5CBA FBE7	崢 5D57 A0A1	昏 5E0B 9AE4	廻 5EFB FC41	健 5FA4 FA61	愀 60A4 A0DC	愀 6150 96A9	悞 61CF 8D77	揸 62C3 9B46	揸 63C1 8FC5	揸 647C 8AC6
媿 5A24 FBA2	媿 5A7E 92F3	媿 5AF0 9EE2	香 5B74 8E48	尔 5C13 FBD6	崢 5CC1 A0F2	崢 5D5B 9C40	岱 5E12 9F75	廐 5EFC FC43	徧 5FA7 FC57	悞 60A7 9468	慙 6159 A06E	懷 61D0 FCA5	担 62C5 FCAE	揸 63D1 93AD	揸 648D 8A5B
媿 5A27 9C51	媿 5A81 9340	媿 5AF2 8F78	孳 5B76 FBC5	尔 5C14 FBD8	崢 5CC2 9868	崢 5D70 98AD	帮 5E2E FBF1	弑 5F0C 9361	徧 5FB1 9B70	悞 60B3 FC6D	愀 615C FCAA	悞 61D3 FCA2	扌 62D5 FCB0	揸 63DE 9DC3	揸 6491 894D
媿 5A2A 94E9	媿 5A82 984D	媿 5AFA F9DC	孳 5B7C FBC7	尪 5C1C 8B5D	崢 5CD1 9F58	崢 5D74 9EEA	冪 5E42 8D69	弑 5F0D FC46	徧 5FBA A051	悞 60D7 8D71	悞 6160 FBCD	悞 61DA 90C3	拟 62DF FA51	揸 63E2 8DA2	揸 64AF FED4

擻 64B4 8A78	敍 654D FCC5	晒 661E 93DB	嗒 669A 9859	杆 6744 FA50	拇 6802 A07D	桥 6865 896A	楚 6918 9BA1	桫 698A 99B6	櫪 6A1A 97F9	櫛 6A8A FBF2	櫟 6B05 93F1	泚 6C35 8BD0	洩 6CB2 9EB6	淝 6D81 8DDA	洎 6E50 FCF9
擗 64B6 93AB	敝 655F FCCB	眈 6623 FE63	曝 66A4 FB52	条 6761 98E7	桡 6803 98FC	栖 6884 8DB9	栲 691A 9AB7	渠 6998 FD52	櫛 6A1C 9558	櫟 6A8F 9670	欵 6B35 FD62	冰 6C37 FD72	洩 6CCB FAC7	洩 6D8F 9CSA	洩 6E59 FB7E
擗 64C0 8DA7	敷 656B 93B3	昞 6630 93D5	曝 66AD FB53	杳 6762 FCF3	荣 6804 8969	椋 6888 917E	椋 691B 8EFC	椋 699F 8DC1	櫛 6A2B 985E	櫟 6A99 8DCB	欵 6B35 FD65	冰 6C39 9CAE	洩 6CCE A042	洩 6D96 FDAD	洩 6E76 92B3
擗 64D3 9F45	敷 656D FCCA	昞 6644 FCDA	曝 66B3 FB4D	杳 6767 FCF2	杳 680D FE4F	椋 6898 93F4	椋 692C 9FA1	椋 69A2 8E46	櫛 6A2C FE7B	櫟 6A9D FD5C	欵 6B52 9FDB	冰 6C3A 8BD1	洩 6CDF 9873	洩 6DA4 8DDC	洩 6E7C FDFE
擗 64DD 8A56	敷 6585 FCC9	咬 6648 9B71	曝 66B6 9CBF	杳 678F 93E5	杳 6810 9256	椋 68A6 FB7C	椋 6936 FD51	椋 69B2 A0D1	椋 6A2D 94CD	櫛 6AA7 8F65	欵 6B57 93F8	冰 6C3D 8ADB	洩 6CEA 9FFC	洩 6DA5 9444	洩 6E86 8DE1
擗 64E1 FCBF	敷 6586 8DAC	晋 664B FCDD	嘻 66BF 9B72	杳 67A0 9A59	椋 681B FAC9	椋 68B6 93E7	椋 693E FAAD	椋 69C0 9FCA	椋 6A33 93EE	櫛 6AAB 8DCD	齒 6B6F 8BF7	汉 6C49 FAE4	洩 6D02 8DD7	洩 6DB1 8DDD	洩 6E8B 95D3
擗 64E5 FCC0	孛 6588 FBC6	晓 6653 8DAF	曝 66CD FB50	杳 67A4 8DB5	杳 681E 93E8	椋 68B9 97EF	椋 6943 8DBE	椋 69D1 92CF	櫛 6A45 FD5A	櫛 6AB1 9DA8	歷 6B74 FD66	汗 6C58 95CE	洩 6D05 92FB	洩 6DB9 A0D6	洩 6E9A 89C1
擗 64E7 8EE6	齊 6589 8967	哈 6657 FAF2	曝 66CE 93BE	杳 67AC FD4D	杳 6822 FCF8	椋 68BD FE4A	椋 6946 89A4	椋 69D5 9CF4	櫛 6A4C 93F5	櫛 6AB2 94F9	夕 6B7A 8BCF	污 6C5A FD76	洩 6D06 8DD8	洩 6E02 97D5	洩 6E85 FD68
擗 64EA 8AA4	斲 65B5 FCCD	晰 6663 93D8	甲 66F1 9DF1	杳 67B1 FD5E	杳 6836 9CE3	黎 68C3 FD45	椋 6955 9AD9	橐 69D6 8DC4	椋 6A52 93EF	櫛 6AB5 8DCE	歿 6B81 8DD1	洩 6C6E FB62	洩 6D24 944F	洩 6E04 944A	洩 6E88 9CB7
擗 650A 8943	旆 65BE 9CF3	皓 6667 FCDF	勗 6702 FCEB	杳 67BF 8F7D	样 6837 FDA9	棟 68C5 96A5	榆 6961 FD4E	椋 69E1 FD41	櫛 6A53 8EEA	櫛 6ABE 93EA	毀 6BC1 8DD2	泠 6C75 8DD4	洩 6D26 8DD9	洩 6E0A 944D	洩 6EBB 8DE3
擗 6511 93F3	旆 65D1 FCD0	晫 666B 93D3	盼 670C A0BB	杳 67D6 9547	杳 683E FC44	棊 68CA FEE0	椋 6964 8DC0	椋 69E9 9B4C	櫛 6A57 8F5B	櫛 6AC8 FD5F	毡 6BDC FD71	洩 6C79 FD78	洩 6D4E 896B	洩 6E0F 97CB	洩 6E99 FAC0
擗 651E FCAB	旆 65D4 95BB	皙 6673 FCE1	聆 670E 9B7E	杳 67D7 FCF6	架 6847 9640	椋 6900 FD48	椋 6967 97F0	椋 69F9 FD57	椋 6A65 8DC6	櫛 6AC9 93F0	毡 6BE1 FD6F	洩 6C7F 8EE3	洩 6D57 97CE	洩 6E15 8DDE	洩 6EDA 8DE5
擗 651F 9EA2	无 65E0 FCD3	琳 667D 8E76	眼 6716 8DB3	杳 67F9 9250	棊 684A 8DB8	椋 6901 FD47	椋 6972 93B4	椋 69FA FCEF	櫛 6A71 8DC8	櫛 6ACA 9FB6	毡 6BEA 8DD3	沟 6C9F 9076	洩 6D5B FAF3	洩 6E18 8DDF	洩 6EDB FA64
劫 6530 9DC7	旆 65E3 FCD4	晒 6685 FC62	暮 671E 9AE8	杳 67FE 8968	柏 6855 9B4A	椋 6902 FEF2	椋 6973 FD44	椋 6A03 9CDE	櫛 6A7A 8DC7	櫛 6AD4 8DCF	璩 6BFA 9FE7	洩 6CA2 98C6	洩 6D5C FDAE	洩 6E29 8DE0	洩 6EDD 8947
支 6534 C6D2	旆 65FF 8DAE	暎 668E 93D1	勝 6725 8EDC	椋 6800 8DB6	椋 6856 8FB9	椋 6903 FE6A	椋 6980 9FA7	椋 6A0B FD42	椋 6A7A 93F7	櫛 6AD8 9763	氘 6C1C 90BD	沪 6CAA 8DD5	洩 6D71 FBAF	洩 6E2A FEF9	洩 6EE2 8DE4
女 6535 8BCE	男 6618 FCD7	暎 6692 8DB1	朶 6736 9CF9	柳 6801 FCFB	椋 685D FCFE	椋 6909 8DBD	椋 6985 8DC2	椋 6A0C 986C	椋 6A82 8DC9	櫛 6AF6 8DD0	氘 6C31 9FD0	沓 6CAF 97D1	洩 6D72 92B7	洩 6E4F FDC0	洩 6E88 8DE7

滩 6EE9 8DE8	溥 6F8A FCBA	灏 7054 8DF7	焮 70A6 986F	焯 7105 9346	焱 7171 9BD5	焜 71B4 FDEA	彪 722E FE47	猓 7302 A04C	玘 7398 92D6	珺 73F7 FE68	琿 7443 92FC	璩 7482 FE7C	璩 7505 A0B7	晙 756D 98D3	瘰 762C FEBD
漶 6EFA FDC7	漉 6F9D FDC5	瀛 705C 8FFA	焯 70A7 FDE2	焮 711D 9863	焱 7173 9AC3	焜 71B7 8DF1	牀 7240 FE48	猓 7304 9E65	玘 739C FAE1	珺 73F9 964E	琿 7445 95EB	璩 748C 9344	璩 750E FEA9	晙 756E FEB4	瘰 763B 9DDD
漉 6F04 FDB0	漉 6F9F FDD2	灏 7067 97D0	点 70B9 98F2	焮 7129 95BC	焱 7175 97C8	焜 71BA FDFB	牀 7250 9455	猓 7310 98B5	玘 739E 91D4	珺 73FB 9765	琿 7447 FE73	璩 748D 8EA6	璩 7519 89C3	晙 7572 98D4	瘰 7640 9EE1
漉 6F0B 9445	漉 6FB5 9CDC	灏 706C 8BD2	焮 70BB 9AFC	焮 712B FDED	焱 7176 A0DB	焜 71D1 8E53	牀 7255 FE4B	猓 7328 FE58	玘 73A7 FADE	珺 7411 89A1	琿 7448 976E	璩 7499 92D3	璩 751E FEAB	晙 757A 9FB9	瘰 764D 98DA
漉 6F0C 97D6	漉 6FB8 95CF	灯 706F 8DF8	焮 70BC 896C	焮 712C FDF7	焱 7177 91D0	焜 71DD FACF	牀 7257 FE4C	猓 732A 9975	玘 73AA FE5B	珺 7412 95FA	琿 7449 FE5F	璩 749B 94B8	璩 7534 9DF4	晙 7583 9471	瘰 764E 9DDF
漉 6F16 FCC6	漉 6FBE 8DEE	灵 7075 90D9	焮 70BD FDFD	焮 7133 9870	焱 717A 9FE4	焜 71EB 96F9	牀 725C 8DBF	猓 732B FE53	玘 73C9 FE5E	珺 7414 92D4	琿 7453 FDBD	璩 74A4 FC71	璩 7535 896D	晙 758D 98D5	瘰 764F FEBF
漉 6F17 9844	漉 6FD3 FDD4	炆 7079 FAF0	焮 70C0 995E	焮 7134 96F6	焱 717C 8FDD	焜 71F5 98BF	牀 7266 9E78	猓 732C A065	玘 73CE FBD7	珺 7415 FE69	琿 7456 92D5	璩 74B4 975E	璩 753B 9C7B	晙 758E FEB8	瘰 7651 FEBE
漉 6F24 8DE9	漉 6FD9 96EC	灾 707E FDE1	焮 70C4 95BD	焮 7135 8EA9	焱 717E 91E9	焜 71F6 9E49	牀 7282 FE51	猓 732E FE59	玘 73CF FE5A	珺 7417 FB45	琿 745D FEB9	璩 74C8 FEA7	璩 7542 98D2	晙 7592 C6D4	瘰 7654 9EEB
漉 6F34 8DEA	漉 6FDA 96EB	灿 707F 8DF9	焮 70CC FDE4	焮 713B 9451	焱 7188 98E0	焜 7209 9BCA	牀 7287 9456	猓 7338 98B7	玘 73D0 94C5	珺 7419 98C8	琿 7460 FE71	璩 74CC 946A	璩 7546 9FA9	晙 759E FEBA	瘰 7666 9E59
漉 6F3D FE50	漉 6FF6 90B6	炆 7081 FDE3	焮 70D0 91E6	焮 713E 8E43	焱 718C 92CA	焜 720E FDFE	牀 728F 9D61	猓 7339 98B8	玘 73D5 FACA	珺 741C 90EF	琿 7465 FBBB	璩 74D0 93E3	璩 754A FEB2	晙 75B1 9ESC	瘰 7667 A05C
漉 6F44 FDCC	漉 6FF8 FDC3	炉 7089 8DFA	威 70D5 FDE5	焮 7140 8B5A	焮 718E 9857	焜 720F 92DC	牀 7294 9457	猓 7341 98BA	玘 73E1 98C1	珺 741E 98C9	琿 7468 947A	璩 74D3 98CF	璩 754D FEB1	晙 75B4 FEBB	瘰 766F FEC0
漉 6F56 9DA7	漉 7003 98AB	炆 708B FB63	焮 70D6 FDE6	焮 7145 FDEE	焱 7196 FDEB	焜 7215 FE41	牀 729F 9966	猓 7348 98BB	玘 73E2 975C	珺 741F 98CA	琿 746B 95FB	璩 74E7 A0D9	璩 7551 97D9	晙 75C3 A044	瘰 7673 9477
漉 6F5C FDCD	漉 701E 96EE	焮 708F 90A6	焮 70DF FDE7	焮 714A FDF0	焱 7198 9B49	焜 7216 91CC	牀 72AD 8BD5	猓 734F 9FBC	玘 73E4 FE74	珺 7437 946D	琿 746C FE77	璩 74F0 A0BF	璩 7553 A0C4	晙 75C8 98D7	瘰 7674 98DC
漉 6F74 FDCF	漉 702C 8DF4	焮 70A0 9970	焮 70F1 9454	焮 714F FDF4	焱 71A2 9D76	焜 7217 91E2	牀 72B2 A069	猓 7371 A04A	玘 73E6 9773	珺 7438 94B7	琿 7474 FE79	璩 74F1 A04D	璩 7555 9476	晙 75DC 98D8	瘰 7676 FEC1
漉 6F79 95D2	漉 704B FDE0	焮 70A3 91EB	焮 70F5 99B8	焮 7151 9BF5	焱 71A3 9EAF	焜 7224 FE44	牀 72CD 98B4	猓 7374 9EC7	玘 73EF FA46	珺 7439 FE6C	琿 7476 FE75	璩 74F2 A0B8	璩 7560 9978	晙 7602 FEBC	瘰 767A 98DE
漉 6F81 8DED	漉 7050 8DF6	焮 70A5 9770	焮 70FE 97E9	焮 716B 977E	焱 71AD 9CCC	焜 722B 8BD3	牀 72E2 A049	猓 738F 98AE	玘 73F3 9764	珺 743C 946B	琿 747A 945D	璩 74F8 A0CE	璩 7567 FEB3	晙 7607 9FFE	瘰 7690 FEC3

皤 76A1 FEC8	睫 7777 8FC7	砵 7818 98F1	碇 7888 94C3	礮 7906 A0A8	褚 7987 89C9	穉 7A3A 94CF	𦵑 7ACF 994C	笱 7B29 8E5E	筲 7BFC 9F64	糝 7C83 8E73	糲 7CED 995C	綵 7DCF 9960	織 7E8E 9EB0	𦵑 7F52 8BD7	稭 8020 9968
皤 76A5 FEC9	睞 7778 94AE	砒 781C 98F3	碍 788D 94C2	礮 792E FEE5	禍 7991 9941	稟 7A3E 9FFA	𦵑 7AD3 9FF8	筲 7B39 996A	纂 7C12 9953	炒 7C86 9F62	繫 7CF3 8E7C	緜 7DD0 9962	纏 7E92 8EB8	𦵑 7F53 8BDA	稭 8025 9969
鼓 76B7 FECA	睞 777A 8A4F	砒 781E 94C1	碇 78AF FEE1	礮 7932 98FD	褚 7999 9942	穉 7A43 91E5	𦵑 7ADA 8E56	笱 7B42 9C64	筲 7C15 FAB8	糝 7C8E 94F6	糲 7CF5 8E7D	綵 7DD3 94FC	𦵑 7E9F 9D70	𦵑 7F71 A0E2	稭 802E 996B
盃 76CC FECB	暄 777B 94B2	砒 7839 98F5	碱 78B1 FEE9	礮 7933 98FB	稷 799D FEF5	穉 7A45 9C6A	𦵑 7ADB 994D	筲 7B43 9CD9	筲 7C1B 9954	糝 7C9C 9958	𦵑 7CF9 8BD9	綵 7DD4 9961	𦵑 7EA4 896E	𦵑 7F78 9FE9	稭 802F 8ED1
盖 76D6 9FC2	瞞 7793 8FD4	砒 783C FA4F	碱 78B6 96E4	礮 7934 FEE8	稷 799F 91D7	穉 7A49 8E49	𦵑 7ADC 91CA	笱 7B55 8E5D	筲 7C35 8E70	糝 7CA6 8E75	幼 7CFC 89A2	緜 7DDC 94FA	纬 7EAC 896F	𦵑 7F8F FDA8	糲 8031 996C
梟 770C 98C4	睞 7798 98EA	硃 783D 96E2	碱 78B8 89AC	礮 7936 8EBF	襪 79A5 94CC	穉 7A65 8E4C	𦵑 7ADD 8E57	筲 7B62 9950	筲 7C42 9F61	糝 7CA7 F9DB	紮 7D25 9ED7	縲 7DE4 8EAE	纺 7EBA 8970	𦵑 7F93 8AE7	耻 803B 8ED4
眈 770E 94B0	瞞 77AF FED8	砒 7842 9450	碇 78B9 96DB	𦵑 793B 8BD8	襪 79A9 FEF8	穉 7A7D 8E4D	𦵑 7AE2 94E1	筲 7B6C 9951	筲 7C44 8E72	糝 7CAC 9072	紮 7D4D A0B6	縲 7DE5 8EB2	织 7EC7 8971	羗 7F97 8EC2	眈 803C 8ED5
映 770F 94B1	瞞 77B9 9DE0	砒 7844 96A2	碇 78C7 FEE2	礼 793C FEF7	籽 79C4 97A8	窃 7A83 9A73	𦵑 7AE7 9047	筲 7B6F 8E62	纂 7C51 A06B	粮 7CAE 94F8	紮 7D5A 9E42	縲 7DF5 8EB0	经 7ECF 8972	羗 7FA3 8EC4	联 8054 996D
眞 771E FED1	瞞 77BE 98EE	砒 7847 98F6	碇 78D2 94C4	𦵑 7958 8F68	秆 79C6 FEFC	窑 7A91 9947	𦵑 7AE9 8FD8	筲 7B7B 9952	纂 7C56 9F40	糝 7CB8 995A	縲 7D5D 8EA4	縲 7DFD 9963	统 7EDF 8973	羹 7FAE 9964	睞 805B A0BE
昵 7724 A0C1	瞞 77C3 95C4	砒 784B 96E5	碇 78D3 FEE3	袜 7959 94C6	焮 79CC FDBF	窑 7AB0 8E50	豎 7AEA 8E58	筲 7B92 8E68	籩 7C5D 94ED	糝 7CC2 A0B0	綉 7D89 8EA7	縲 7DFE 97AA	纜 7F06 8974	羗 7FB4 9965	睞 8061 8ED6
眈 7726 FED2	瞞 77F4 FCE8	砒 7851 98F7	碇 78D7 FEE7	𦵑 7962 9DEA	杭 79D4 FEFE	窻 7ABB 8E4F	笱 7AFE 94EB	筲 7BA2 8E61	籩 7C6D 94EE	糝 7CC7 8E79	網 7D97 9542	縲 7E07 94FB	卸 7F37 8975	𦵑 7FDD 954E	睞 8062 A0BC
畔 772B A0CD	瞞 77CB 98EF	砒 7853 A046	碇 78D8 9FFB	祝 7971 FC69	矜 79E2 96D1	窻 7ABC 9949	筲 7B0B 8E5C	籩 7BA3 9F59	籩 7C70 9FBD	糝 7CC9 8E78	縲 7DA4 987D	縲 7E27 8EBB	𦵑 7F40 8EBC	𦵑 7FE7 98B3	睞 8063 A0B5
着 7740 FED3	疾 77E6 FAD8	砒 7854 96E3	碇 78EE 93C9	稜 797E 9CDA	桐 79F1 94D5	寮 7AC2 8E51	筲 7B0C 9553	笱 7BB2 8BB3	籩 7C74 8E7B	糝 7CCD 94F3	縲 7DA8 9755	縲 7E65 9876	鋼 7F41 8EBD	𦵑 7FFA 8ECB	睞 8066 A0B4
睞 7743 98E5	矜 77F4 FEDC	砒 7866 98F8	碇 78F0 94E8	稟 7980 FEF3	矜 79F4 94D0	竈 7AC3 8E52	笔 7B14 9FE5	笱 7BCF 9F5D	类 7C7B 9957	穀 7CD3 98AF	綉 7DAB 8EA8	縲 7E67 8EA1	罇 7F47 8EBE	𦵑 8002 8BDF	𦵑 8080 8BE0
畏 7758 FED6	砒 77AE A0AE	砒 787A 9EE4	碇 78F1 FB56	植 7983 9C72	稭 7A06 9944	竈 7AC8 9AB2	笱 7B1F 9F56	籩 7BD0 8E66	糝 7C7C 94F7	糝 7CDA A0B2	縲 7DB3 8EAA	縲 7E6E 8EB7	罇 7F49 9DD1	耇 8008 8ECE	𦵑 809F 89B5
睞 7772 91E4	砒 7808 9D4C	碇 7881 F9D6	碇 78F5 90C5	裨 7986 FEF0	稽 7A2D A0B3	竈 7AC9 89A5	笱 7B27 954F	籩 7BFA 8E6E	糝 7C7E 9F5F	糝 7CE6 8E7A	縲 7DCD 89A3	縲 7E7F 9DA6	縲 7F4E 94FD	粗 801D 8ECF	𦵑 80A7 8EDD

胝 80B6 9E5D	脚 811A 8EE0	膈 81B6 9E61	卅 8279 994A	茱 82FF 99B2	莽 83BE 9FC6	葦 844A 8F66	蒨 84AD 9AF2	勝 8542 FAB9	藁 8616 8F7E	蠟 8786 9E5F	蠶 882D 957C	衽 88B5 8FC4	西 8980 98E2	詠 8A38 99D7	潮 8B3F 8FE2
肱 80B7 9971	晞 812A 935C	賺 81C1 99AA	艺 827A 8976	茈 830B 9E68	葱 83CD FAAC	蒨 8453 956E	蒨 84BD 96C3	蒨 854B 8F40	藜 8628 8FAA	蝮 878B 99CD	蚋 8842 9FC7	袿 88BF 95A4	霸 8987 8FC9	詢 8A3D 95B5	謔 8B43 A0CC
胼 80BC 89AE	脈 8132 9DE6	臍 81C8 A0C8	芳 827B 8F48	荔 8318 8F4A	菓 83D3 8F58	苻 8455 9245	蒨 84BE 99BD	藟 854C FA44	藟 862F A050	蟹 878C A0C9	衅 8845 8FBB	装 88C5 8FC6	羈 8989 A0C2	誨 8A49 A0CA	誨 8B4C 8FE3
肱 80BD 9DE8	脍 8134 8B5F	馭 81E4 99AB	芾 8287 FBEE	茆 831A 8F42	落 83ED 9848	蓄 8458 8F60	蓀 84DA A0CF	蕒 8552 99C2	藟 8642 90D3	蟾 87A5 9ADB	衆 8846 8FBC	衲 88C7 9E60	羈 898A 8FCA	譽 8A67 9FFD	膺 8B4D 8FE4
胆 80C6 9565	脗 8137 9563	臬 81EF FEC4	芦 82A6 99AE	茆 831D 8F51	萆 8405 99B7	萆 845C 9ED1	萆 84DE 8F6D	萆 855A 8F5C	藟 8645 9556	蝮 87A9 A0C6	衍 884F 8FEC	裏 88CF F9D8	規 8991 99D4	詢 8A7E A058	謔 8B5E 9BC4
肱 80E9 9972	脗 8142 9567	莛 81F6 98C2	茆 82AA 8EFB	茆 833D 9846	萆 8414 9665	萆 8462 FECF	萆 84E1 99BE	萆 856F 99C4	虬 866C 8FB8	蝮 87B1 8FB4	衛 885E 8FC0	裏 88E6 95A5	覓 8994 A0B9	誨 8A90 8FD6	謔 8B62 9BFC
脗 80EC 8B5C	脗 8148 9DE3	館 8218 8EE8	茆 82C4 8B52	茆 8357 99B4	萆 8416 FA6C	萆 8464 99B9	萆 84E2 8EF4	萆 8570 99C5	虬 8672 99C8	蝮 87C1 A0D7	衛 8860 936A	裏 88F5 9CB3	覓 89A5 9B58	誨 8A94 99D8	謔 8B69 964C
脗 80F6 89B1	脗 8156 997C	脗 821A A0BA	茆 82CA 99B0	茆 8362 8EF5	萆 8418 9DE7	萆 8471 8F62	萆 84E4 8F72	萆 8573 8F7B	虬 867E 8FAF	蝮 87CE A0C7	衲 8864 8BE4	衲 88FF 99D1	覓 89A7 8FCD	誨 8A9C 8FD3	謔 8B81 9AF6
脗 8103 A0C0	脗 8159 997D	脗 8226 FD77	茆 82CF 8977	茆 8363 FD55	萆 841C 9E62	萆 8472 974C	萆 84E5 95E4	萆 85C1 8FA3	虬 8692 99C9	蝮 87D6 A043	衲 8865 9C7C	衲 8900 FEF1	覓 89A9 A0D4	誨 8AA9 8FE5	謔 8B90 8FE7
脗 8107 8EDF	脗 815A 997E	脗 8229 8EEE	茆 82D0 8F41	茆 8366 9CCD	萆 8420 96CC	萆 847F 91C7	萆 84F8 99BF	萆 85E0 99C6	虬 86A0 9579	蝮 87DA 8FB5	衲 886E 95A1	衲 8924 99D2	覓 89BC 8FCE	誨 8AAF 8FE9	謔 8B9B 8FE8
脗 8109 9566	脗 816D 8B5B	脗 822D 9EBF	茆 82D8 99B1	茆 836F 8978	萆 8421 8E67	萆 8480 955F	萆 8503 9242	萆 85EE 96CD	虬 86AD 9F49	蝮 87EE 8FB2	衲 8884 FECC	衲 8943 9CC2	覓 89C1 8BE5	誨 8AB4 99D9	謔 8BA0 8BE7
脗 810C 9974	脗 817C 99A3	脗 823E 89C2	茆 82E2 8F49	茆 8385 8F53	萆 8424 FC75	萆 8488 99BB	萆 8505 FBA5	萆 85FC 96C7	虬 86B2 99CA	蝮 87F5 A061	衲 8887 95A3	衲 8947 99D3	覓 89C6 8979	誨 8ADA 927C	謔 8BBE 897A
脗 810E 9976	脗 8184 99A4	脗 8254 99AC	茆 82EE FA4D	茆 8391 8F6F	萆 8426 987E	萆 8492 8E6D	萆 8510 99C0	萆 8602 8FA5	虬 86EF 99CB	蝮 8804 9E5E	衲 889C 8FC1	衲 894D 95A7	覓 89E7 8FD0	誨 8AEA 9C45	謔 8BE2 897B
脗 8112 9977	脗 8193 99A6	脗 8262 956B	茆 82F7 9DE4	茆 839C 8E63	萆 842E FDB9	萆 8493 8F71	萆 8533 FDB4	萆 860D FABB	虬 8770 9DD5	蝮 880F 8FB6	衲 88A0 A052	衲 8954 95A9	覓 8A1C 95B6	誨 8B0C 8FDE	謔 8C51 99DA
脗 8114 9979	脗 81A5 99A8	脗 8265 956C	茆 82FC FBE9	茆 83AC 8F56	萆 843E 97FC	萆 8496 94CB	萆 8534 8F77	萆 8610 9570	虬 8771 8FB0	蝮 8818 9FE8	衲 88AE 99D0	衲 8965 95A6	覓 8A29 99D6	誨 8B1F 8FDF	謔 8C9B 8FED
脗 8117 9DDA	脗 81AA 8ABE	脗 8276 99AF	茆 82FD 9B54	茆 83B9 FE76	萆 8448 98F9	萆 84A3 95B1	萆 8538 99C1	萆 8614 9368	虬 877D FA7A	蝮 8827 9CB2	衲 88B4 8FC3	衲 8977 9C5D	覓 8A2B 95E5	誨 8B2D A04B	謔 8C9F 95C0

質 8CAD A0CB	貝 8D1D 8BE8	蹶 8E68 8AA7	𨾏 8EED 99ED	𨾏 8FB6 9AA8	迢 9033 99F3	醜 9170 9E71	鈺 9213 99F7	鉤 9281 9CA8	鈺 92F2 93FC	鋇 9348 96D9	鎬 9387 946C	鎬 93F3 91DB	鏢 9454 9A51	鎮 9547 9D74	阨 9638 A0AA
贓 8CCD 9E48	趁 8D7A 92C1	躡 8E71 99E6	帖 8EF2 99EE	𨾏 8FB7 99EF	邇 9037 9062	酶 9176 9E4A	鈺 9228 99F9	鉤 9284 9772	鑄 92F3 9A42	錕 935F 9774	錕 9390 9858	鋸 9401 97AF	鋸 9458 96A7	長 9578 8BEA	阨 9641 9FA6
賔 8CD4 99DB	趁 8D82 9FD6	蹶 8E75 9FF7	輒 8F19 904C	邇 8FB8 FEEB	邇 904C 9F55	醜 917C 9FDC	鉅 922A 9663	錕 9289 9440	鏡 92F4 9A43	鎬 9362 FDF5	鑿 939C 9266	鑿 9404 95DD	鑿 945B 90B0	長 957F 8BEB	际 9645 99CC
賒 8CD6 8FF3	趨 8DA6 A0D2	蹶 8E77 9FED	輒 8F2D 904D	邇 8FB9 9DA3	邇 9056 9BF9	醜 918C 89AB	鉅 922B 95B9	錕 928F 92F2	鏡 92F6 9659	鎬 9366 92E5	鑿 93A0 93FB	鑿 9408 9348	鑿 9465 9C4E	閨 9585 90B2	陵 9656 9C59
贊 8CDB 8FF9	趨 8DA9 9040	躡 8E7E 8A5C	暢 8F30 95CB	邇 8FBA 9DA1	邇 9061 9065	醜 918E 9FB8	鉅 9235 94D4	錕 92AE 99FD	錕 92FD 9A44	鎬 9368 9645	鎮 93AD 9A47	鑿 9417 9A4B	鑿 9467 9443	閨 9596 95E9	險 9669 99B5
賒 8CE9 95C1	踟 8DC0 8AC4	躡 8E80 9DAE	輒 8F41 97E2	邇 8FBC 9943	邇 9064 96E0	醜 91A9 9070	鉅 923C FCFA	錕 92B1 99FC	鑿 9303 9051	鎬 9369 91DA	鑿 93B8 9749	鑿 941B FC45	鑿 946C 8EBA	閨 9597 95E8	陞 967B 90BE
賈 8CEB A04E	跃 8DC3 99E0	躡 8EA7 95C9	轉 8F4A 95CC	邇 8FBC 9945	邇 906C 98BE	醜 91B6 8B63	鉅 9241 9077	錕 92B9 F9D7	鎬 9307 94BF	鑿 936B 90A3	鑿 93BB 9748	鑿 941D 9A4D	鑿 9479 9A52	閨 9599 95E6	陞 9681 9FAF
賈 8CF2 99DC	踟 8DD4 9FF0	躡 8EAD 9048	輒 8F5C 9F78	邇 8FBE 9D7D	邇 90A8 9068	醜 91BB 95DC	鉅 9244 90AB	錕 92BA 964A	鎬 932C 90A2	鑿 936E A05F	鑿 93BD 934A	鑿 9424 91BC	鑿 947B FCC1	閨 95A0 90B5	隨 968F 95F2
賈 8CF7 A064	踟 8E01 9FF3	躡 8EB0 99E8	車 8F66 897C	邇 8FC1 99F0	邇 90AE 906C	醜 91C4 9071	鉅 9255 9D4D	錕 92BE 96D8	鎬 9330 9CAB	鑿 9373 90AF	鑿 93BF 9CE2	鑿 9425 90E2	車 9485 8BE9	閨 95A2 9A54	陞 9696 90BF
聽 8D03 8FF7	踟 8E0E 9DBF	躡 8EB6 9049	軋 8F67 897D	邇 8FCA 99F1	邇 90BB 95D8	鉅 91D6 FC5E	鉅 9258 99FA	錕 92BF 99FE	鎬 9331 9776	鑿 9374 97BF	鑿 93C6 9264	鑿 9426 90B4	鐘 949F 9CAF	閨 95A6 90B3	隣 96A3 90C1
賈 8D0B 89B0	踟 8E28 9FF6	躡 8EBC 90B1	輪 8F6E 897E	邇 8FCC 99F2	邇 90C4 906A	鉅 91DF 8949	鉅 925D 92E3	錕 92D4 904B	鎬 9340 FC55	鑿 9378 914C	鑿 93CB 91DF	鑿 9427 95E1	鋼 94A2 8BFD	閨 95A7 95E7	陞 96A5 FEE4
賈 8D0C A048	踟 8E2A 95C8	躡 8EC3 904A	輸 8F93 995D	邇 8FD0 9D60	邇 9151 9FB2	鉅 91E5 965B	鉅 925F 97BB	錕 92DB FA41	鎬 9341 FE45	鑿 937D 967A	鑿 93D3 FB79	鑿 942D 9A4E	鐵 94C1 9ABC	閨 95AA 8B50	隸 96B6 90C4
顛 8D11 8FFB	踟 8E2D 9E5A	害 8ECE 99EA	鼻 8FA0 9B5A	邇 8FDA A0A3	邇 9159 9FAE	鉅 91FA 94A6	鉅 9262 9078	錕 92E3 9A40	鎬 9342 94A8	鑿 9381 91DE	鑿 93DB 96D7	鑿 943E 9A4F	鈴 94C3 9AB8	門 95E8 8BEC	隸 96BD 90C7
賢 8D12 8FF6	躡 8E3A 99E3	軋 8EDA 9BD1	辭 8FA5 9050	迹 8FF9 905B	醜 915C 9FB0	鉅 91FE 8FD5	鉅 926B 99FB	錕 92E5 975B	鎬 9343 9A45	鑿 9384 9A46	鑿 93E0 9343	鑿 9442 FE40	銅 94DC 9AAE	間 95F4 9A56	雲 96F4 92E4
賈 8D18 9DDC	踟 8E46 8A4A	轉 8EE2 99EB	焚 8FB3 9054	邇 9008 9EDB	醜 915E 89AD	鉅 9208 9E73	鉅 926E 97E0	錕 92EB 9A41	鎬 9344 FA4B	鑿 9385 FEB0	鑿 93F0 FDCB	鑿 9443 FE43	銀 94F6 9AA7	𨾏 961D 8BFB	霽 9703 9F52
贓 8D1C 99DD	踟 8E4F 9FF1	軋 8EE4 99EC	走 8FB5 C6D6	邇 9012 9D79	醜 9167 906E	鉅 920E 9075	鉅 9277 96DC	錕 92EC 91DD	鎬 9345 9DE1	鑿 9386 9779	鑿 93F1 FE7A	鑿 944D 96DD	錠 952D 9A53	陽 9633 9A57	弱 971B 90DB

霽 9721 A066	鞫 97B2 9A5D	頤 9815 8A74	颺 98C8 9143	饴 9939 914D	駃 99DA 9FAB	駿 9A8F 89C7	舖 9B34 9164	釧 9BCF 96B3	鰓 9C2F 9ADA	鴝 9D44 A05E	鷓 9DC9 89B8	馨 9E98 9F6D	駿 9EE2 9AAF	齧 9F69 91C9	
霽 9731 90D2	鞫 97B4 9F7A	頤 981F 9657	颺 98CA 9141	饴 993B 9666	罵 99E1 8EC1	匏 9AB2 8A6A	鸞 9B39 9F41	鯛 9BDD 9A76	鰲 9C35 96B0	鴛 9D49 9A7D	鷺 9DD4 9173	麇 9E9E 91AC	騰 9EF1 9AB0	齒 9F7F 8DE6	
霽 9736 90D4	鞫 97B8 9B5C	頤 9823 9CEF	颺 98CE 8BF0	饴 9940 9F7B	鴛 99E6 9555	舐 9AB6 8B57	魁 9B40 9169	鯨 9BE9 95D5	鯨 9C3A 9A7E	鴝 9D4E 8948	鷓 9DFC 9AA6	麇 9EA2 91AD	驢 9EF8 9AB1	龐 9F8E 91CB	
霽 9740 9A5B	鞫 97BA 9F7C	頤 982E 9FDF	颺 98DC 9660	饴 9942 9A6B	駃 99F5 9152	駮 9ABA 9FE1	魁 9B50 9168	鯨 9BED 9ECA	鯨 9C45 9DDE	鴝 9D50 9EB1	鷓 9E0A 89BD	麥 9EA6 A0FD	鼈 9EFE 9AA1	龍 9F99 89C8	
霽 9741 95FD	鞫 97BD FC52	頤 9833 90F7	颺 98DE 8BF1	饴 994A A06C	駃 9A0C 9153	駮 9ABD 9B5F	鯨 9B69 9A74	鯨 9BF1 9A77	鯨 9C4F 96AD	鴝 9D5E 9DDB	鷓 9E0C 89B9	麇 9EA8 9FE2	鼈 9F02 91B9	龜 9F9C 8BF8	
青 9751 8BC4	鞫 97BE 90E9	頤 9834 90F6	颺 98E0 99F6	饴 994D 9667	駃 9A10 9155	駮 9AD7 A05D	鯨 9B7F 96B2	鯨 9BF4 9A78	鯨 9C53 96AE	鴝 9D6D 95BF	鷓 9E0E 917D	麇 9EAA 91AF	鼈 9F08 91BA	龟 9F9F 8DAA	
靛 9757 90DE	鞫 97C0 90EA	頤 9847 9B5E	颺 98E1 9149	饴 995D 9A6C	駃 9A1F 955D	駮 9AE0 915B	鯨 9B81 9A75	鯨 9BFF 9170	鯨 9C5D 9EA1	鴝 9D6E 8A73	鷓 9E18 96BB	麇 9EAB 9E41	鼈 9F17 91BE	顛 9FA5 9FDD	
靛 975D 9CE4	鞫 97C2 9A5E	頤 984B 90F8	颺 98E6 914A	饴 9962 9A6D	駃 9A21 9671	駮 9AE2 915C	鯨 9B83 FDA5	鯨 9C02 916F	鯨 9C72 9E50	鴝 9D7C 9EFE	鷓 9E1C 9FF2	麇 9EAC 9AAA	鼈 9F26 A041	” FF02 C8D0	
靛 975F 90E1	鞫 97C8 9F76	頤 9866 90F9	颺 98EC 914B	饴 9963 8BF2	駃 9A26 9C6D	駮 9AF4 915E	鯨 9B8B 9EE9	鯨 9C0A 9FA3	鯨 9C7B 96AF	鴝 9D7E 917A	鷓 9E1F 8BF5	麇 9EAF 91B0	鼈 9F27 8BB7	’ FF07 C8CF	
靛 976D 9E46	鞫 97D2 90EB	頤 986C FA6A	颺 98F1 9A64	饴 999B 966A	駃 9A2F 9673	駮 9AFF 9F5C	鯨 9B8D 8BBA	鯨 9C0C 9171	鯨 9C7C 8BF4	鴝 9D83 917B	鷓 9E7B 9AA9	麇 9EB1 9AAB	鼈 9F39 91C0	[FF3B C6E4	
靛 9771 9651	鞫 97E0 90EC	頤 9875 8BEF	颺 98F5 8ABF	饴 99A4 FCEA	駃 9A3B 9154	駮 9B02 9F57	鯨 9B8E 916D	鯨 9C10 96B1	鯨 9D02 9FA4	鴝 9D93 9AA3	鷓 9E81 9F54	麇 9EBD 9AAC	鼈 9F44 9AB3] FF3D C6E5	
靛 9787 FB58	鞫 97E6 8BEE	頤 98B4 9FE0	颺 990E 9A66	饴 99AA 966C	駃 9A3C 9A71	駮 9B09 9F65	鯨 9B8F A060	鯨 9C15 9F63	鯨 9D0C 96BD	鴝 9DA5 96C2	鷓 9E84 9FE3	麇 9EBF 9A4A	鼈 9F45 91C3	— FFE2 C8CD	
靛 9789 90E6	鞫 97EE 90EE	頤 98B7 9142	颺 9919 9A67	饴 99B8 91C4	駃 9A58 9156	駮 9B0F 9A72	鯨 9B97 9FDE	鯨 9C1B 9F67	鯨 9D16 96F4	鴝 9DAB 9F77	鷓 9E85 9EED	麇 9EC1 91B2	鼈 9F50 A0FC	 FFE4 C8CE	
靛 979B 9650	鞫 97F2 91C6	頤 98B9 9A62	颺 991C 9A69	饴 99BC 9677	駃 9A5C 966D	駮 9B14 9160	鯨 9B9D 9FC3	鯨 9C1F 8BB9	鯨 9D21 96B8	鴝 9DBD 9AA4	鷓 9E90 91AA	麇 9EC4 8BF6	鼈 9F53 9FEE	■ FFE4 F9FE	
靛 979F 90E7	鞫 97F5 90F2	頤 98C3 9569	颺 9937 9A6A	饴 99C4 99F4	駃 9A63 9557	駮 9B2A 9F5E	鯨 9B9F 96B5	鯨 9C20 9A7A	鯨 9D34 FAA1	鴝 9DC0 9AA5	鷓 9E95 91AB	麇 9EC6 9AAD	鼈 9F5A 9F69		
靛 97B1 90E8	鞫 9814 FCBC	頤 98C7 9144	颺 9938 9652	饴 99C5 9A6F	駃 9A6C 89C6	駮 9B2D 9161	鯨 9B80 A067	鯨 9C26 8B56	鯨 9D39 91A7	鴝 9DC4 91A1	鷓 9E96 A070	麇 9EC7 89B6	鼈 9F62 91C8		

Annex I Lists of Characters in the GCCS Not Included in the HKSCS

1. Unified Characters

The characters in the second column of the following table are not included in the HKSCS. However, the code points in the first column are reserved as compatibility points for backward compatibility.

Big-5 Code (Compatibility point)	Character	Unified with	
		Code Point	Character
FA5F	倩	ADC5	倩
FA66	偽	B0B0	偽
FABD	包	A55D	包
FAC5	卅	A2CD	卅
FAD5	卿	ADEB	卿
FB48	嘅	9DEF	嘅
FBB8	婷	B440	婷
FBF3	𠂇	C9DB	𠂇
FBF9	廐	9DFB	廐
FC4F	彘	D8F4	彘
FC6C	愬	A0DC	愬
FCB9	撐	BCB5	撐
FCE2	晴	B4B8	晴
FCF1	杞	A7FB	杞
FDB7	泔	CB58	泔
FDB8	渝	B4FC	渝
FDBB	港	B4E4	港
FDF1	煮	B54E	煮
FE52	猪	9975	猪
FE6F	瑜	B7EC	瑜
FEAA	𣎵	A260	𣎵
FEDD	𣎵	CFF1	𣎵
8E69	箸	BAE6	箸
8E6F	窳	EDCA	窳

8E7E	糲	A261	糲
8EAB	緒	BAFC	緒
8EB4	績	BFA6	績
8ECD	者	AACC	者
8ED0	耨	BFAE	耨
8F57	菁	B5D7	菁
8F69	蒨	E3C8	蒨
8F6E	蒨	DB79	蒨
8FCB	覩	BFCC	覩
8FCC	覩	A0D4	覩
8FFE	起	B05F	起
906D	都	B3A3	都
907A	銹	F9D7	銹
90DC	靜	C052	靜
90F1	響	C554	響
91BF	叢	F1E3	叢
9244	強	9242	強
92AF	尅	A259	尅
92B0	尅	A25A	尅
92B1	尅	A25C	尅
92B2	尅	A25B	尅
92C8	鑰	A05F	鑰
92D1	臻	E6AB	臻
9447	涅	D256	涅
94CA	禛	E6D0	禛
95D9	邗	CA52	邗
9644	瀛	9CE4	瀛
96ED	澗	96EE	澗
96FC	嫫	E959	嫫
9B76	熾	EFF9	熾
9B78	轟	C5F7	轟
9B7B	類	F5E8	類
9BC6	駘	E8CD	駘
9BDE	鈇	D0C0	鈇

9BEC	愀	FD64	愀
9BF6	澶	BF47	澶
9C42	輻	EBC9	輻
9C53	悅	CDE7	悅
9C62	營	C0E7	營
9C68	鄧	DC52	鄧
9C6B	鷺	F86D	鷺
9C77	荷	DB5D	荷
9CBC	𠂇	C95C	𠂇
9CBD	秣	AFB0	秣
9CD0	婧	D4D1	婧
9D57	峯	E07C	峯
9D5A	筑	B5AE	筑
9DC4	拐	A9E4	拐
9EA9	恢	ABEC	恢
9EEF	痺	DECD	痺
9EFD	汙	C9FC	汙
9F60	鬪	F9C4	鬪
9F66	𧈧	91BE	𧈧
9FCB	僭	B9B0	僭
9FD8	弑	9361	弑
A063	蟻	8FB6	蟻
A077	拎	A9F0	拎
A0D5	璿	947A	璿
A0DF	莞	DE72	莞
A0E4	牖	9455	牖

2. Characters not verifiable

The following characters are not included in the HKSCS. However, the code points are reserved as compatibility points for backward compatibility.

Big-5 Code (Compatibility Point)	Character
9EAC	糴
9EC4	穢
9EF4	踣
9F4E	纏
9FAD	噁
9FB1	醜
9FC0	薛
9FC8	彘
9FDA	膺
9FE6	澹
9FEA	訶
9FEF	鉏
A054	執
A057	熵
A05A	恚
A062	癩
A072	𪗇
A0A5	嗽
A0AD	礮
A0AF	糲
A0D3	亂
A0E1	慙

Annex II List of Compatibility Points and Their Corresponding Characters in ISO 10646 v1.0

The following is an example of an entry in this Annex:

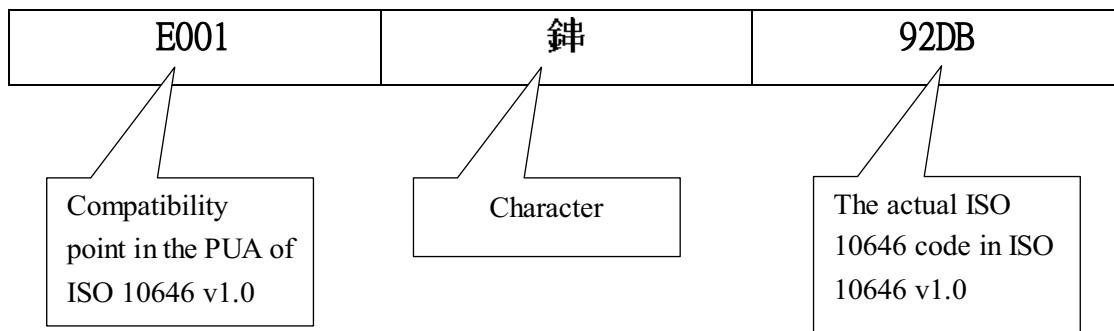

E001	錚	92DB
E004	藟	854C
E006	瑤	73EF
E007	况	51B5
E00B	鯨	9344
E00D	莅	82EE
E00F	砿	783C
E010	杆	6744
E011	拟	62DF
E017	佞	4FAB
E019	俅	5008
E01F	倩	**
E021	健	5FA4
E024	淫	6EDB
E026	僞	**
E027	僑	5101
E029	徹	510E
E02A	顛	986C
E02C	莧	8416
E02F	堯	5160
E031	兪	516A
E039	宀	5B82
E03A	蟪	877D
E03D	冲	51B2
E03E	泮	51B8
E03F	鴿	9D34
E040	凉	51C9
E041	減	51CF
E042	凌	51D1
E044	凜	51D3
E046	决	51B3
E047	儿	51E2
E048	儿	5342
E049	凭	51ED
E04A	蒼	83CD
E04B	榆	693E
E04D	彻	5F7B
E04E	刊	520B
E04F	刮	5226
E050	劫	523C
E051	券	52B5

E052	劓	5257
E053	劓	5294
E054	効	52B9
E055	勅	52C5
E056	斂	7C15
E057	勝	8542
E058	勳	52E0
E059	勳	860D
E05B	包	**
E05D	唛	5549
E05E	滙	6ED9
E062	匱	5333
E063	什	**
E065	泮	6CCB
E067	協	681B
E068	協	73D5
E069	協	604A
E06D	爆	71DD
E06F	叩	536D
E070	却	5374
E072	鄂	537E
E073	卿	**
E076	疾	77E6
E077	厓	5393
E079	厠	53A0
E07A	厥	53AB
E07B	厥	53AE
E07C	玃	73A7
E07F	玃	739C
E080	叁	53C1
E081	叁	53C5
E082	汉	6C49
E083	义	4E49
E084	堅	57FE
E085	叙	53D9
E088	叠	53E0
E08B	叶	53F6
E08D	吓	5413
E08E	炆	7079
E08F	唸	552B
E090	哈	6657

E091	滄	6D5B
E092	卮	546D
E095	啞	555D
E096	咏	548F
E097	咤	54A4
E09F	商	5547
E0A1	白	542F
E0A2	琫	7417
E0A3	喆	5586
E0A4	喻	55A9
E0A5	嚙	**
E0AA	瞽	66B3
E0AC	嗥	5637
E0AD	嗥	66CD
E0AF	嗥	66A4
E0B0	嗥	66AD
E0B1	噍	564D
E0B2	喻	564F
E0B3	磅	78F1
E0B4	鹵	56F1
E0B5	鞣	9787
E0B6	𠂔	53FE
E0B7	罔	5700
E0B8	罔	56EF
E0B9	罔	56ED
E0BD	坟	5746
E0BF	洵	6C6E
E0C0	烱	708B
E0C1	坂	5742
E0C4	塤	57E6
E0C6	塹	5803
E0C9	堦	5826
E0CB	塚	585C
E0CC	塹	58AA
E0CE	壠	58E0
E0CF	壘	58DC
E0D1	壻	58FB
E0D2	寿	5BFF
E0D3	玩	5743
E0D6	總	93D3
E0D8	够	591F

E0D9	梦	68A6
E0DB	湊	6E59
E0DD	裝	5A24
E0DE	啓	5553
E0E0	藹	8505
E0E1	姊	59C9
E0E6	姪	59D9
E0EA	派	6D71
E0ED	姪	59F9
E0EF	媿	5AAB
E0F0	媿	5A63
E0F3	媿	**
E0F5	媿	5A96
E0F6	璵	7465
E0F7	媿	5AD3
E0FE	広	5E83
E0FF	勑	52D0
E100	孳	5B76
E101	孳	6588
E102	孳	5B7C
E107	孳	5BD5
E108	傲	6160
E10C	寶	5BF3
E10D	宝	5B9D
E10F	尅	5C05
E111	尔	5C13
E112	尔	73CE
E113	尔	5C14
E116	屈	5C49
E118	岷	5C85
E119	峯	5CE9
E11A	峯	5CEF
E11B	嶼	5D8B
E11E	崑	5D10
E11F	崑	5D18
E120	替	5D46
E122	岑	5CBA
E123	巖	5DD7
E124	茱	82FC
E129	茱	8287
E12C	幫	5E2E

E12D	櫛	6A8A
E12E	𠂔	**
E12F	么	5E7A
E132	厦	53A6
E133	廉	4EB7
E134	廐	**
E135	厨	53A8
E137	盼	5E09
E138	𠂔	5EF4
E13A	迫	5EF9
E13B	廻	5EFB
E13D	迺	5EFC
E13E	栾	683E
E13F	鐸	941B
E140	式	5F0D
E146	强	5F3A
E149	彘	**
E14B	彘	5F63
E14C	轡	97BD
E14E	彘	5F72
E14F	錫	9340
E151	徧	5FA7
E152	徧	5DB6
E158	劔	91D6
E15B	忽	6031
E15C	暄	6685
E161	逦	5790
E163	祝	7971
E165	悞	609E
E166	息	**
E167	息	60B3
E16B	璉	74A4
E16C	德	50E1
E16D	媼	5AA0
E16E	愨	6164
E16F	萤	8424
E170	憑	6142
E173	悞	6181
E174	澗	51F4
E176	愨	6187
E177	究	5BAA

E17A	悞	61D3
E17D	懷	61D0
E181	恣	6023
E182	慙	615C
E183	攏	651E
E184	撼	638B
E186	担	62C5
E188	拈	62D5
E18A	拈	636C
E18D	撻	6438
E18E	撻	63F8
E191	撻	**
E192	撻	6F8A
E194	嶼	9814
E197	擡	64E1
E198	擎	64E5
E199	鑿	947B
E19B	携	643A
E19D	絃	654D
E19E	激	6F16
E1A1	敷	6585
E1A2	敷	656D
E1A3	敷	655F
E1A5	斷	65B5
E1A8	旃	65D1
E1AB	无	65E0
E1AC	既	65E3
E1AD	攸	5FDF
E1AF	舅	6618
E1B2	咄	6644
E1B5	晋	664B
E1B7	皓	6667
E1B9	皙	6673
E1BA	晴	**
E1C0	瞿	77C5
E1C2	鵠	99A4
E1C3	勗	6702
E1C7	穰	69FA
E1C9	杞	**
E1CA	杙	6767
E1CB	李	6762

E1CE	杙	67D7
E1D0	栢	6822
E1D1	泊	6E50
E1D2	鉞	923C
E1D3	柳	6801
E1D6	栲	685D
E1D8	榛	69E1
E1D9	槲	6A0B
E1DB	煤	6973
E1DC	黎	68C3
E1DE	椁	6901
E1DF	椁	6900
E1E4	枌	67AC
E1E5	榆	6961
E1E8	櫻	6936
E1E9	渠	6998
E1EC	榮	8363
E1ED	僑	5090
E1EE	棹	69F9
E1F1	撫	6A45
E1F3	檝	6A9D
E1F5	枱	67B1
E1F6	櫟	6AC8
E1F9	鬱	6B1D
E1FB	愀	60DE
E1FC	欸	6B35
E1FD	歷	6B74
E1FF	澱	6EB5
E204	吡	5421
E206	毡	6BE1
E208	毡	6BDC
E209	冰	6C37
E20D	污	6C5A
E20E	猷	8226
E20F	涵	6C79
E21A	鯁	9B83
E21D	彰	7F8F
E21E	样	6837
E222	涖	6D96
E223	浜	6D5C
E224	滉	6E7C

E225	滉	6F04
E229	菁	8533
E22B	淞	51C7
E22C	洗	**
E22D	渝	**
E22E	箭	842E
E230	港	**
E232	琰	7453
E234	焮	79CC
E235	湏	6E4F
E236	燻	5A91
E238	澹	6FF8
E23A	澗	6F9D
E23C	澗	6EFA
E240	鏞	93F0
E241	漱	6F44
E242	潛	6F5C
E244	潛	6F74
E247	凜	6F9F
E249	濂	6FD3
E250	澗	51DF
E255	澗	704B
E256	灾	707E
E257	焮	70A7
E258	炆	7081
E259	焮	70CC
E25A	威	70D5
E25B	裁	70D6
E25C	烟	70DF
E25F	熈	71B4
E260	焮	7196
E262	焮	712B
E263	熈	7145
E264	焮	5A88
E265	焮	714A
E266	煮	**
E267	邕	5C9C
E269	焮	714F
E26A	錫	9362
E26C	煬	712C
E270	煬	71BA

E272	焮	70BD
E273	燎	720E
E274	鑪	9442
E275	燮	7215
E276	燮	5911
E277	鑪	9443
E278	燼	7224
E279	斂	9341
E27B	脍	722E
E27C	牀	7240
E27E	楛	68BD
E27F	臆	7255
E280	牖	7257
E283	柱	680D
E284	渾	6F3D
E285	犂	7282
E286	猪	**
E287	猫	732B
E28C	獾	7328
E28D	猷	732E
E28E	珏	73CF
E28F	玲	73AA
E292	珉	73C9
E293	璫	7449
E297	眵	6623
E29C	玦	73F7
E29D	琕	7415
E29E	椐	6903
E2A0	棗	7439
E2A3	瑜	**
E2A5	璫	7460
E2A7	璫	7447
E2A8	瑤	73E4
E2A9	瑤	7476
E2AA	莹	83B9
E2AB	莹	746C
E2AD	穀	7474
E2AE	鐘	93F1
E2AF	櫛	6A2C
E2B0	璫	7482
E2B6	璫	5B46

E2B9	璫	74C8
E2BB	甌	750E
E2BC	甌	**
E2BD	甌	751E
E2C0	甌	5BD7
E2C2	鏢	9385
E2C3	哂	754D
E2C4	哂	754A
E2C5	畧	7567
E2C6	晦	756E
E2CA	疎	758E
E2CB	瑋	745D
E2CC	疔	759E
E2CD	疔	75B4
E2CE	瘞	7602
E2CF	瘰	762C
E2D0	瘰	7651
E2D1	瘰	764F
E2D2	瘰	766F
E2D3	𤑔	7676
E2D5	臬	7690
E2D6	臬	81EF
E2DA	皞	76A1
E2DB	皞	76A5
E2DC	鼓	76B7
E2DD	盃	76CC
E2DF	盞	8462
E2E3	眞	771E
E2E4	眦	7726
E2E5	着	7740
E2E6	擗	64AF
E2E8	畷	7758
E2EA	瞞	77AF
E2EE	矻	77F4
E2EF	善	**
E2F2	碁	68CA
E2F3	碁	78AF
E2F4	碁	78C7
E2F5	碁	78D3
E2F6	墮	96A5
E2F7	礮	792E

E2F9	磚	78D7
E2FA	礪	7934
E2FB	礪	78B1
E2FD	迈	8FB8
E2FE	袄	8884
E302	裨	7986
E303	祺	8900
E304	椽	6902
E305	稟	7980
E307	襖	799D
E309	礼	793C
E30A	襖	79A9
E30B	馮	6E2A
E30E	秆	79C6
E310	杭	79D4
E312	埠	57BE
E314	熇	713E
E317	椽	69A2
E319	香	5B74
E31A	釋	7A49
E31D	換	7A65
E31E	牽	7A7D
E320	窻	7ABB
E321	窻	7AB0
E322	窻	7AC2
E323	窻	7AC3
E324	燿	71D1
E327	竝	7ADA
E328	竝	7ADD
E329	豎	7AEA
E32B	咲	54B2
E32D	笋	7B0B
E32E	符	7B55
E32F	笱	7B29
E332	笱	7BA2
E333	筋	7B6F
E334	筱	839C
E337	籬	7BD0
E338	箔	8421
E339	箒	7B92
E33A	箒	**

E33E	篩	8492
E33F	籬	7BFA
E340	筵	**
E341	籬	7C35
E343	籬	7C44
E344	糝	7C83
E346	莽	7CA6
E347	琳	667D
E349	糗	7CC9
E34A	糗	7CC7
E34B	糗	7CE6
E34C	糗	7C74
E34D	糗	7CF3
E34E	糗	7CF5
E34F	糗	**
E350	糗	7E67
E353	綺	7D5D
E355	璣	748D
E356	綉	7D89
E357	綉	7DAB
E358	爛	7135
E359	綉	7DB3
E35A	緒	**
E35D	縹	7DE4
E35F	縹	7DF5
E361	縹	7DE5
E363	縹	**
E366	縹	7E6E
E367	縹	7E92
E369	縹	946C
E36A	縹	7E27
E36B	縹	7F40
E36C	縹	7F41
E36D	縹	7F47
E36E	縹	7936
E370	罵	99E1
E371	羗	7F97
E373	羗	7FA3
E37A	翽	7FFA
E37C	耆	**
E37D	耆	8008

E37E	粗	801D
E37F	穉	**
E380	穫	802F
E383	耻	803B
E384	聃	803C
E385	聰	8061
E38B	勝	6725
E38C	胚	80A7
E38E	脇	8107
E38F	脚	811A
E390	壇	58B0
E392	浮	6C7F
E395	攀	64E7
E397	館	8218
E399	櫛	6A53
E39D	肱	8229
E3A1	偃	4FF9
E3A3	萌	84E2
E3A4	芋	8362
E3AA	芪	82AA
E3AB	梳	691B
E3AE	莖	854B
E3AF	第	82D0
E3B0	節	831A
E3B6	芳	827B
E3B7	旨	82E2
E3B8	荔	8318
E3BF	苞	831D
E3C0	响	55EC
E3C1	莅	8385
E3C4	菟	83AC
E3C5	菁	**
E3C6	巢	83D3
E3C9	楠	6A57
E3CA	萼	855A
E3CE	蓄	8458
E3D0	葱	8471
E3D3	櫛	6AA7
E3D4	筭	844A
E3D6	祿	7958
E3D7	蓓	**

E3DB	齶	84DE
E3DC	齶	**
E3DD	峯	8391
E3DF	純	8493
E3E0	浸	84E4
E3E5	蘇	8534
E3E6	嫵	5AF2
E3E9	簡	8573
E3EB	枿	67BF
E3EC	藜	8616
E3EF	藁	85C1
E3F1	藜	8602
E3F6	藜	8628
E3F9	号	53F7
E3FB	虾	867E
E3FC	蠱	8771
E3FE	蟾	87EE
E400	蟹	87B1
E401	蟹	87DA
E402	蟹	880F
E403	瞻	5661
E404	虬	866C
E405	柚	6856
E407	岬	8845
E408	衆	8846
E40C	衛	885E
E40D	袜	889C
E40F	袴	88B4
E410	袂	88B5
E411	擯	63C1
E412	裝	88C5
E413	睫	7777
E415	霸	8987
E416	羈	898A
E417	覲	**
E418	覲	**
E419	覽	89A7
E41A	覲	89BC
E41C	解	89E7
E41F	諉	8A9C
E420	馴	7793

E421	鈺	91FE
E422	識	8A90
E424	焯	7AE9
E429	燭	717C
E42A	譌	8B0C
E42B	譌	8B1F
E42E	譌	8B3F
E42F	譌	8B4C
E430	磨	8B4D
E431	言	8AA9
E433	讐	8B90
E434	讐	8B9B
E435	詔	8AAF
E438	衍	884F
E439	獾	8C9B
E43F	賒	8CD6
E442	賢	8D12
E443	賤	8D03
E445	贊	8CDB
E446	瀛	705C
E447	贛	8D11
E44A	起	**
E44B	趕	8DA9
E452	靖	7AE7
E453	駝	8EAD
E454	裸	8EB6
E455	驪	8EC3
E456	鏡	92D4
E457	輒	8F19
E458	輒	8F2D
E45B	辭	8FA5
E45C	鑿	9303
E45F	麓	8FB3
E464	廸	5EF8
E466	迹	8FF9
E46D	邊	9037
E470	邈	9061
E473	邨	90A8
E475	邨	90C4
E477	邨	90AE
E478	邨	**

E479	酌	9167
E47B	醴	91A9
E47C	醴	91C4
E47D	糶	7CAC
E480	鈎	920E
E481	沟	6C9F
E482	鈇	9241
E483	鉢	9262
E485	鏽	**
E48B	鍊	932C
E48C	鏊	936B
E48F	炊	708F
E490	嬪	5AC3
E494	鉄	9244
E498	鑿	9373
E499	鑛	945B
E49A	脹	8EBC
E49B	閉	9585
E49C	閱	95A6
E49D	鏞	9426
E49E	閩	95A0
E49F	濶	6FF6
E4A6	氘	6C1C
E4A7	墜	967B
E4A8	隴	9696
E4AA	隣	96A3
E4AC	懔	61DA
E4AD	隸	96B6
E4AE	礪	78F5
E4B0	隼	96BD
E4B1	双	53CC
E4BB	霽	9731
E4BC	霧	8642
E4BD	霧	9736
E4C2	灵	7075
E4C3	霎	5B41
E4C4	霧	971B
E4C5	靜	**
E4C7	靛	9757
E4C8	嬪	5B4A
E4CA	輩	975F

E4CB	鐙	9425
E4CC	僭	50D0
E4CF	鞞	9789
E4D0	鞞	979F
E4D1	鞞	97B1
E4D2	鞞	97BE
E4D3	鞞	97C0
E4D4	鞞	97D2
E4D5	鞞	97E0
E4D7	鞞	97EE
E4D8	鞞	741C
E4DA	鞞	**
E4DB	鞞	97F5
E4DF	鞞	9834
E4E0	鞞	9833
E4E1	鞞	984B
E4E2	鞞	9866
E4E9	鞞	98CA
E4EA	鞞	98B7
E4EB	鞞	98C8
E4EC	鞞	98C7
E4F0	鞞	55B0
E4F1	鞞	98E1
E4F2	鞞	98E6
E4F3	鞞	98EC
E4F4	鞞	9378
E4F5	鞞	9939
E4FA	鞞	99F5
E4FB	鞞	9A0C
E4FC	鞞	9A3B
E4FD	鞞	9A10
E4FE	鞞	9A58
E503	鞞	9AE0
E504	鞞	9AE2
E506	鞞	9AF4
E508	鞞	9B14
E509	鞞	9B2D
E50B	鞞	5034
E50C	鞞	9B34
E510	鞞	9B50
E511	鞞	9B40

E513	媯	5A45
E515	媯	9B8E
E517	媯	9C02
E518	媯	9BFF
E519	媯	9C0C
E51B	媯	9DD4
E522	媯	9D7E
E523	媯	9D83
E525	媯	9E0E
E526	媯	6888
E527	媯	9DC4
E52D	媯	9D39
E530	媯	9E90
E531	媯	9E95
E532	媯	9E9E
E533	媯	9EA2
E535	媯	9EAA
E536	媯	9EAF
E538	媯	9EC1
E53C	媯	4F32
E53F	媯	9F02
E540	媯	9F08
E542	媯	9424
E544	媯	9F17
E545	媯	**
E546	媯	9F39
E547	媯	569F
E548	媯	568A
E549	媯	9F45
E54A	媯	99B8
E54C	媯	97F2
E54D	媯	847F
E54E	媯	9F62
E54F	媯	9F69
E550	媯	7ADC
E551	媯	9F8E
E552	媯	7216
E556	媯	7177
E55A	媯	739E
E55D	媯	799F
E560	媯	9369

E561	媯	93F3
E563	媯	92EC
E564	媯	9381
E565	媯	93CB
E568	媯	7217
E56A	媯	7772
E56B	媯	7A43
E56C	媯	70D0
E56F	媯	717E
E571	媯	70A3
E581	媯	575B
E587	媯	8503
E589	媯	**
E58A	媯	8455
E595	媯	67F9
E599	媯	586C
E59B	媯	6810
E5A2	媯	54CB
E5A3	媯	569E
E5A5	媯	5692
E5A9	媯	93C6
E5AB	媯	939C
E5AC	媯	4EF8
E5AD	媯	512B
E5B0	媯	4EBC
E5B3	媯	4F4B
E5B4	媯	4F8A
E5B6	媯	5A68
E5BD	媯	4F29
E5C1	媯	8ADA
E5C3	媯	4E98
E5C4	媯	50CD
E5C5	媯	510D
E5C6	媯	4FA2
E5C7	媯	4F03
E5CA	媯	4F42
E5CB	媯	502E
E5CC	媯	506C
E5CD	媯	5081
E5CE	媯	4FCC
E5CF	媯	4FE5

E5D0	媯	5058
E5D1	媯	50FC
E5D2	媯	**
E5D3	媯	**
E5D4	媯	**
E5D5	媯	**
E5D6	媯	6E76
E5DA	媯	6D72
E5DD	媯	51A8
E5DE	媯	51C3
E5E4	媯	8D7A
E5E7	媯	5259
E5E8	媯	52A4
E5EA	媯	52E1
E5EB	媯	**
E5ED	媯	718C
E5F2	媯	69D1
E5F4	媯	**
E5F6	媯	7499
E5F7	媯	7414
E5F8	媯	7456
E5F9	媯	7398
E5FD	媯	53D0
E5FF	媯	720F
E601	媯	55B4
E603	媯	54CD
E605	媯	571D
E606	媯	925D
E607	媯	96F4
E608	媯	9366
E609	媯	57DD
E60A	媯	578D
E60B	媯	577F
E60D	媯	58CB
E60E	媯	5A99
E613	媯	5A2C
E614	媯	59B8
E615	媯	928F
E616	媯	5A7E
E617	媯	5ACF
E618	媯	5A12

E61E	洩	6D05
E61F	瑤	7443
E620	媿	5A21
E622	嫵	5A81
E625	鑿	93E0
E626	瑣	748C
E628	焯	7105
E62A	鑄	9408
E62C	鑿	93BD
E62E	寮	5C1E
E62F	咋	5C9E
E630	樓	5E5E
E631	嶼	5E48
E635	廊	5ECD
E636	嬾	5B4F
E63E	睇	812A
E643	弑	5F0C
E644	弑	5F0E
E647	媿	5A6B
E649	嫵	5B44
E64A	贛	8614
E64C	衡	8860
E64D	忙	607E
E650	帆	5FDB
E656	愴	61C0
E65A	愴	6199
E65B	愴	6198
E65C	惠	6075
E661	撻	6471
E669	擲	6337
E66B	擲	64B6
E66C	撻	6331
E66D	捏	63D1
E670	护	62A4
E672	彝	643B
E673	敷	656B
E674	械	6972
E67A	皖	550D
E67E	曝	66CE
E689	礪	78EE
E691	暎	668E

E693	暎	666B
E695	暎	6630
E698	晰	6663
E69B	晒	661E
E6A3	璫	74D0
E6A5	枌	678F
E6A7	梔	68B6
E6A8	棗	681E
E6AA	森	6ABE
E6AE	榑	6A33
E6AF	榑	6A52
E6B0	櫥	6AC9
E6B1	櫥	6B05
E6B3	擲	6511
E6B4	梔	6898
E6B5	櫥	6A4C
E6B7	櫥	6A7A
E6B8	獻	6B57
E6BB	鏗	93A0
E6BC	鋏	92F2
E6BF	肆	9289
E6C2	鏡	9467
E6C3	淳	6DA5
E6C4	滌	6F0B
E6C6	涅	**
E6C9	洩	6E04
E6CB	嫁	5A3D
E6CC	淵	6E0A
E6CD	瑄	5847
E6CE	淦	6D24
E6CF	砗	7842
E6D0	焯	713B
E6D3	焯	70F1
E6D4	焯	7250
E6D5	彝	7287
E6D6	彝	7294
E6D9	茲	5179
E6DC	瑞	747A
E6E7	懶	60A7
E6E9	瓊	74CC
E6EA	瓊	743C

E6EB	錮	9387
E6EC	瑤	7437
E6F0	瞳	7583
E6F5	曷	7555
E6F6	癩	7673
E6F9	璫	7468
E703	鈺	91FA
E704	圻	5732
E705	銓	9342
E708	儼	50DF
E70B	睇	7778
E70D	眇	770E
E70E	映	770F
E70F	眩	777B
E714	瑋	7438
E715	璫	749B
E71C	鎔	9307
E71E	硃	781E
E71F	碍	788D
E720	碇	7888
E721	碇	78D2
E722	珞	73D0
E723	袜	7959
E727	禳	**
E728	冀	8496
E729	襪	79A5
E72A	襪	6A2D
E72C	穉	7A3A
E72D	稔	79F4
E731	鈔	9235
E732	桐	79F1
E739	嗜	556B
E73E	嫉	7AE2
E73F	嬋	5A59
E743	娥	5A0D
E745	礪	78F0
E746	媿	5A2A
E748	筮	7AFE
E74A	籟	7C5D
E74B	籟	7C6D
E750	糞	7CCD

E753	糞	7C8E
E754	糞	7C7C
E755	糞	7CAE
E756	糞	6AB2
E757	糞	7DDC
E758	糞	7E07
E759	糞	7DD3
E75A	糞	7F4E
E75E	網	7D97
E763	柶	67D6
E766	峰	57C4
E76A	翹	7FDD
E76B	箒	7B27
E76F	穿	7BOC
E771	鶯	99E6
E772	藤	8645
E773	驢	9A63
E774	樵	6A1C
E779	輸	9A1F
E77B	葦	8480
E77F	荆	8137
E781	胆	80C6
E782	脉	8109
E783	腓	8142
E785	颯	98C3
E787	艦	8262
E788	艦	8265
E78A	淇	8453
E78C	護	8610
E78E	嫵	5A86
E791	燦	5B2B
E793	燦	5AE4
E795	釜	86A0
E798	蠶	882D
E79A	媿	5A02
E79B	袞	886E
E79C	侏	4F45
E79D	衲	8887
E79E	袷	88BF
E79F	袷	88E6
E7A0	襪	8965

E7A1	襍	894D
E7A3	襍	8954
E7AB	襍	84A3
E7AF	詢	8A3D
E7B0	紛	8A1C
E7B2	曠	5F4D
E7B3	鉸	922B
E7B5	捷	65D4
E7B6	炯	7129
E7B7	炫	70C4
E7B9	鷓	9D6D
E7BA	貞	8C9F
E7BB	賒	8CE9
E7BD	姪	599A
E7BE	暉	77C3
E7BF	姁	59F0
E7C2	踪	8E2A
E7C3	躡	8EA7
E7C5	暢	8F30
E7C6	轉	8F4A
E7C8	汗	6C58
E7C9	濛	6FBB
E7CC	濛	6F79
E7CD	溢	6E8B
E7CF	輪	9BE9
E7D2	邨	90BB
E7D3	邨	**
E7D4	啱	5571
E7D6	鑄	91BB
E7D7	鑄	9404
E7DB	鑄	9427
E7DE	蓋	84E5
E7DF	訖	8A2B
E7E0	鬧	9599
E7E1	鬧	95A7
E7E2	鬧	9597
E7E3	鬧	9596
E7E5	堤	7445
E7EC	隨	968F
E7F4	瑋	7412
E7F5	瑤	746B

E7F7	靄	9741
E7F9	架	6847
E7FD	靄	**
E7FE	鏗	9368
E803	鑿	92BA
E804	鏡	5B11
E805	鏡	8B69
E807	城	73F9
E809	轄	979B
E80A	軋	9771
E80B	鏗	9938
E80D	嶠	5DC1
E810	頤	981F
E812	鏡	92F6
E814	鈔	91E5
E819	鑿	98DC
E81C	鉅	922A
E81E	摺	8414
E81F	饒	993B
E820	饒	994D
E823	馥	999B
E825	馥	99AA
E826	驛	9A5C
E829	櫟	6A8F
E82A	駟	9A21
E82B	嬌	5AFE
E82C	駟	9A2F
E830	駟	99BC
E833	鎬	937D
E834	場	5872
E836	塚	5822
E839	砒	7844
E83C	榑	68C5
E83E	鑄	9458
E840	惹	6150
E843	悵	6107
E844	鱒	9C4F
E845	鱒	9C53
E846	鱒	9C7B
E847	鱒	9C35
E848	鱒	9C10

E849	鯨	9B7F
E84A	鯨	9BCF
E84C	鯨	9B9F
E84F	鴟	9D21
E852	鸛	9E18
E854	鸛	9D0C
E859	鸛	9DA5
E85A	惹	84BD
E85E	惹	85FC
E863	萌	8420
E864	蘊	85EE
E868	矜	79E2
E86E	錦	93DB
E86F	錄	92BE
E870	鎡	9348
E872	碓	78B9
E873	拱	9277
E874	鑿	944D
E875	倂	4FE4
E877	馮	9064
E879	研	783D
E87A	砒	7854
E87B	磳	78B6
E87C	砒	784B
E881	佖	4F72
E882	灤	6FDA
E883	澗	6FD9
E884	澗	**
E885	澗	701E
E886	咄	5414
E888	坭	57BB
E889	壳	58F3
E88A	坭	578A
E88B	鴟	9D16
E88C	埒	57D7
E88D	焮	7134
E890	熾	71EB
E893	嫫	**
E896	煥	610C
E897	娉	5ACE
E898	娟	5A0B

E89E	鑛	93BB
E89F	鑛	93B8
E8A2	蓊	8472
E8A8	航	5994
E8AB	縻	7DA8
E8B1	錕	92E5
E8B2	琅	73E2
E8B4	璫	74B4
E8B9	櫛	6AD8
E8BA	璫	73F3
E8BB	璫	73FB
E8C4	璫	7448
E8C6	煇	70A5
E8C8	鉤	9284
E8C9	鉤	73E6
E8CA	鐳	935F
E8CC	鐳	9331
E8CF	鉤	9386
E8D4	燧	716B
E8D7	噤	56A4
E8DB	峪	5502
E8DC	籽	79C4
E8DE	纏	7DFE
E8E3	斲	9401
E8E7	姪	59B0
E8EB	嫫	5AA1
E8EF	鈺	925F
E8F0	嫫	5A79
E8F3	鎬	9374
E8F8	僮	50F4
E8FC	焮	7175
E8FF	漪	6E0F
E902	淩	6D57
E904	灑	7067
E905	砦	6CAF
E909	漫	6E02
E90A	瀟	6FOC
E90D	焮	7551
E913	媼	59C4
E914	鉶	926E
E916	輶	8F41

E919	垠	5812
E91A	垠	57C8
E91D	垠	70FE
E923	垠	68B9
E924	垠	6967
E92D	垠	6A1A
E930	垠	843E
E937	垠	6F17
E939	垠	833D
E93B	垠	83ED
E93F	垠	5989
E940	垠	5A82
E942	垠	5A61
E943	垠	5A71
E947	垠	59EF
E94A	垠	718E
E94B	垠	9390
E94C	垠	669A
E94E	垠	5A6E
E94F	垠	5A2B
E951	垠	6A2B
E956	垠	711D
E959	垠	4FB0
E95B	垠	5CC2
E95F	垠	6A0C
E962	垠	70A6
E963	垠	7133
E966	垠	6CDF
E969	垠	7E65
E96A	垠	59EB
E96B	垠	5D2F
E96D	垠	5F5C
E970	垠	7DA4
E971	垠	8426
E972	垠	5485
E976	垠	577E
E97C	垠	7003
E97E	垠	5D70
E97F	垠	738F
E980	垠	7CD3
E983	垠	4FC8

E984	垠	7FE7
E985	垠	72CD
E986	垠	7310
E988	垠	7338
E989	垠	7339
E98B	垠	7341
E98C	垠	7348
E98F	垠	906C
E990	垠	71F5
E992	垠	73E1
E993	垠	81F6
E995	垠	770C
E997	垠	6CA2
E998	垠	56FD
E999	垠	7419
E99A	垠	741E
E99B	垠	741F
E9A0	垠	74D3
E9A3	垠	7542
E9A4	垠	756D
E9A5	垠	7572
E9A6	垠	758D
E9A8	垠	75C8
E9A9	垠	75DC
E9AB	垠	764D
E9AD	垠	7674
E9AF	垠	767A
E9B1	垠	7188
E9B2	垠	5623
E9B3	垠	8980
E9B4	垠	5869
E9B6	垠	7743
E9B8	垠	6761
E9BB	垠	7798
E9BE	垠	5C5E
E9BF	垠	77BE
E9C0	垠	77CB
E9C1	垠	58F2
E9C2	垠	7818
E9C3	垠	70B9
E9C4	垠	781C

E9C6	垠	7839
E9C7	垠	7847
E9C8	垠	7851
E9C9	垠	7866
E9CA	垠	8448
E9CC	垠	7933
E9CD	垠	6803
E9CE	垠	7932
E9D1	垠	7991
E9D2	垠	7999
E9D3	垠	8FBB
E9D4	垠	7A06
E9D5	垠	8FBC
E9D7	垠	7A91
E9D9	垠	7ABC
E9DA	垠	8279
E9DC	垠	7ACF
E9DD	垠	7ADB
E9DF	垠	4E21
E9E0	垠	7B62
E9E1	垠	7B6C
E9E2	垠	7B7B
E9E3	垠	7C12
E9E4	垠	7C1B
E9E7	垠	7C7B
E9E8	垠	7C9C
E9EA	垠	7CB8
E9EC	垠	7CED
E9ED	垠	8F93
E9EE	垠	70C0
E9F0	垠	7DCF
E9F1	垠	7DD4
E9F2	垠	7DD0
E9F3	垠	7DFD
E9F4	垠	7FAE
E9F5	垠	7FB4
E9F6	垠	729F
E9F8	垠	8020
E9F9	垠	8025
E9FA	垠	7B39
E9FB	垠	802E

E9FC	垠	8031
E9FD	垠	8054
E9FF	垠	57B4
EA00	垠	70A0
EA01	垠	80B7
EA02	垠	80E9
EA04	垠	810C
EA05	垠	732A
EA06	垠	810E
EA07	垠	8112
EA08	垠	7560
EA09	垠	8114
EA0C	垠	8156
EA0D	垠	8159
EA0E	垠	815A
EA10	垠	583A
EA11	垠	817C
EA12	垠	8184
EA14	垠	8193
EA16	垠	81A5
EA17	垠	57EF
EA18	垠	81C1
EA19	垠	81E4
EA1A	垠	8254
EA1C	垠	82A6
EA1D	垠	8276
EA1E	垠	82CA
EA1F	垠	82D8
EA20	垠	82FF
EA22	垠	8357
EA23	垠	9669
EA24	垠	698A
EA25	垠	8405
EA26	垠	70F5
EA27	垠	8464
EA28	垠	60E3
EA29	垠	8488
EA2B	垠	84BE
EA2C	垠	84E1
EA2D	垠	84F8
EA2E	垠	8510

EA2F	菟	8538
EA30	蕒	8552
EA32	蔞	856F
EA33	蕒	8570
EA34	蕒	85E0
EA36	蚱	8672
EA37	蚱	8692
EA38	蚱	86B2
EA39	蚱	86EF
EA3A	际	9645
EA3B	蚱	878B
EA3E	祢	88AE
EA3F	椅	88FF
EA40	襖	8924
EA41	襖	8947
EA42	覬	8991
EA44	詈	8A29
EA45	詈	8A38
EA46	誕	8A94
EA47	諒	8AB4
EA48	黠	8C51
EA49	賁	8CD4
EA4A	賁	8CF2
EA4B	贓	8D1C
EA4D	莖	585F
EA4E	跃	8DC3
EA50	佞	4EEE
EA51	躡	8E3A
EA52	嚙	55D8
EA53	歪	5754
EA54	躡	8E71
EA55	唳	55F5
EA56	躡	8EB0
EA58	害	8ECE
EA59	轉	8EE2
EA5A	轉	8EE4
EA5B	轉	8EED
EA5C	帖	8EF2
EA5D	迂	8FB7
EA5E	迂	8FC1
EA5F	迂	8FCA

EA60	迕	8FCC
EA61	渣	9033
EA62	馱	99C4
EA64	餉	98E0
EA65	鈺	9213
EA67	鈺	9228
EA68	銻	9258
EA69	鉤	926B
EA6A	錦	92B1
EA6B	銻	92AE
EA6C	鋪	92BF
EA6D	鄒	92E3
EA6E	犁	92EB
EA6F	鑄	92F3
EA70	鏡	92F4
EA71	鍔	92FD
EA72	總	9343
EA73	銀	9384
EA74	鎮	93AD
EA77	鷹	9EBF
EA78	鏞	9417
EA79	兂	5301
EA7A	鏞	941D
EA7B	鏞	942D
EA7C	鏞	943E
EA7E	鏞	9454
EA7F	鏞	9479
EA80	錠	952D
EA81	閱	95A2
EA83	间	95F4
EA84	阳	9633
EA86	杵	67A0
EA88	囊	9740
EA8A	鞞	97B2
EA8B	鞞	97C2
EA8C	噎	5654
EA8E	慘	60E8
EA8F	鷹	98B9
EA91	殮	98F1
EA92	墻	5844
EA93	餉	990E

EA94	餉	9919
EA95	呀	51B4
EA96	餉	991C
EA97	餉	9937
EA98	餉	9942
EA99	餉	995D
EA9A	餉	9962
EA9C	馱	99C5
EA9E	聽	9A3C
EA9F	鬆	9B0F
EAA0	窃	7A83
EAA1	鮒	9B69
EAA2	鮒	9B81
EAA3	鮒	9BDD
EAA4	鮒	9BF1
EAA5	鮒	9BF4
EAA7	鮒	9C20
EAAA	鸞	9D49
EAAB	鸞	9C3A
EAAC	鸞	9EFE
EAAD	鸞	5650
EAAE	鸞	9D93
EAAF	鸞	9DBD
EAB0	鸞	9DC0
EAB1	鸞	9DFC
EAB2	銀	94F6
EAB3	之	8FB6
EAB4	謙	9E7B
EAB5	藪	9EAC
EAB6	藪	9EB1
EAB7	麼	9EBD
EAB8	鯁	9EC6
EAB9	銅	94DC
EABA	駿	9EE2
EABB	騰	9EF1
EABC	驢	9EF8
EABD	驢	7AC8
EABE	驢	9F44
EAC2	櫛	691A
EAC3	鈴	94C3
EAC4	妬	59AC

EAC6	墀	5840
EAC7	鉄	94C1
EACD	块	5757
EACE	焗	7173
EAD2	呪	546A
EAD5	呀	549E
EADB	惧	60E7
EADD	嘶	567A
EAE4	檣	6955
EAE5	鰓	9C2F
EAE6	鰓	87A5
EAED	鈔	5C20
EAEF	帑	5E0B
EAF3	暮	671E
E AFC	鹵	5364
EAFD	蕘	84AD
EB01	譚	8B81
EB06	嚙	4E78
EB07	炆	70BB
EB10	柝	62C3
EB13	熿	7198
EB14	柏	6855
EB16	槩	69E9
EB1E	菘	82FD
EB22	鯁	89A5
EB24	鼻	8FA0
EB26	鞞	97B8
EB28	頓	9847
EB29	駭	9ABD
EB3A	標	5FB1
EB3B	咬	6648
EB3C	嗜	66BF
EB40	熿	**
EB42	熿	**
EB45	類	**
EB47	墀	58B5
EB48	聆	670E
EB49	楚	6918
EB5C	渣	51D2
EB5E	晏	599F
EB64	堊	5788

EB6C	讓	8B5E
EB6E	駘	**
EB72	熾	7209
EB75	奧	5965
EB79	軼	8EDA
EB7B	劓	528F
EB7C	圻	573F
EB7D	焯	7171
EB82	噫	55BC
EB86	鉉	**
EB91	僭	5066
EB94	愀	**
EB9C	堊	57A1
EB9D	煑	7151
EB9E	澶	**
EBA1	適	9056
EBA4	譏	8B62
EBA7	崙	5D5B
EBA9	輜	**
EBAC	諄	8AEA
EBB5	鑪	9465
EBB7	橙	6195
EBB8	媿	5A27
EBBA	悅	**
EBBB	嶸	56B9
EBBE	洳	4E6A
EBC0	陵	9656
EBC1	涎	6D8F
EBC4	擗	8977
EBC9	營	**
EBCB	滌	7B42
EBCF	鄧	**
EBD1	穰	7A45
EBD2	鷲	**
EBD4	騶	9A26
EBD9	植	7983
EBDC	崱	5D2C
EBDE	荷	**
EBE2	画	753B
EBE3	补	8865
EBE5	堊	58B6

EBED	鉤	9281
EBF0	鉉	9330
EBF3	沘	6C39
EBF4	钟	949F
EBF7	臺	8827
EBF8	裴	88F5
EBFC	溱	6EB8
EC01	尠	**
EC02	秣	**
EC04	曠	66B6
EC07	襲	8943
EC0A	囀	56D6
EC11	焚	71AD
EC12	笨	8366
EC15	婧	**
EC1E	箇	7B43
EC1F	稜	797E
EC21	漸	6FB5
EC23	糊	6A03
EC25	厝	53A2
EC27	鎗	93BF
EC28	梱	6836
EC29	醜	975D
EC30	整	5D85
EC33	團	5715
EC34	頤	9823
EC36	嶸	5DAB
EC38	旆	65BE
EC39	櫟	69D5
EC3A	豸	53D2
EC3E	朶	6736
EC4E	擿	63E6
EC50	砢	7808
EC51	鉅	9255
EC59	妍	59F8
EC5B	峯	**
EC5E	筑	**
EC64	运	8FD0
EC65	擗	728F
EC66	疇	568B
EC74	纒	7E9F

EC78	鎮	9547
EC7A	燧	71A2
EC7D	逶	9012
EC81	达	8FBE
EC82	唬	55C1
EC83	辺	8FBA
EC85	辺	8FB9
EC88	鑑	7E7F
EC89	潛	6F56
EC8A	檟	6AB1
EC8B	儀	4EEA
EC90	躓	8E80
EC9C	亞	4E9A
EC9F	嚙	56BF
ECA1	跖	8E0E
ECA2	預	5B6D
ECA5	措	63DE
ECA6	拐	**
ECA9	劫	6530
ECAA	嘍	562D
ECAC	呬	541A
ECB1	嘢	5622
ECB2	嘞	561E
ECB3	罈	7F49
ECB5	玎	5975
ECB7	蝻	8770
ECB8	东	4E1C
ECBC	膈	8117
ECBD	鷲	9D5E
ECBE	贖	8D18
ECBF	瘰	763B
ECC0	鱸	9C45
ECC1	癩	764E
ECC2	蹇	77B9
ECC3	鉉	9345
ECC4	引	5432
ECC5	臍	8148
ECC6	甘	82F7
ECC7	岷	5625
ECC8	脉	8132
ECC9	葵	8418

ECCA	肱	80BD
ECCB	嗑	55EA
ECCC	祢	7962
ECCD	噤	5643
ECCE	吡	5416
ECD1	嘅	5605
ECD2	噲	55F1
ECD3	甲	66F1
ECD6	占	7534
ECD7	咽	55F0
ECD8	噤	55BA
ECD9	咗	5497
ECDA	啲	5572
ECDD	既	5ED0
ECE2	麤	9EAB
ECE3	緬	7D5A
ECE4	噉	55DE
ECE6	拗	629D
ECE7	韌	976D
ECE8	咋	5494
ECE9	脏	8CCD
ECEA	濃	71F6
ECEB	酶	9176
ECEC	擗	63FC
ECED	猛	63B9
ECEE	搵	63FE
ECEF	啱	5569
ECF1	鱻	9C72
ECF3	冫	519A
ECF6	冫	51A7
ECF7	呔	544D
ECF8	啱	551E
ECF9	啍	5513
ECFA	擗	7666
ECFB	躄	8E2D
ECFD	疮	75B1
ECFE	肱	80B6
ECFF	螭	8804
ED00	螭	8786
ED01	袖	88C7
ED02	膈	81B6

ED03	𪗇	841C
ED06	𪗈	7304
ED08	𪗉	5B90
ED09	𪗊	830B
ED0B	𪗋	567B
ED12	𪗌	9170
ED14	𪗍	9208
ED19	𪗎	7266
ED20	𪗏	9C5D
ED21	𪗐	651F
ED28	𪗑	**
ED2B	𪗒	##
ED2E	𪗓	71A3
ED2F	𪗔	7E8E
ED30	𪗕	9D50
ED31	𪗖	4E1A
ED32	𪗗	4E04
ED34	𪗘	5B0D
ED35	𪗙	6CB2
ED36	𪗚	5367
ED39	𪗛	537D
ED3C	𪗜	589A
ED3E	𪗝	822D
ED3F	𪗞	544B
ED40	𪗟	57AA
ED43	𪗠	##
ED46	𪗡	7374
ED49	𪗢	9BED
ED50	𪗣	845C
ED55	𪗤	632E
ED56	𪗥	7D25
ED5A	𪗦	9008
ED5B	𪗧	52CC
ED60	𪗨	7640
ED61	𪗩	5AF0
ED63	𪗪	787A
ED65	𪗫	58A7
ED67	𪗬	567C
ED68	𪗭	9B8B
ED69	𪗮	5D74
ED6A	𪗯	7654

ED6C	𪗰	9E85
ED6E	𪗱	**
ED70	𪗲	6119
ED73	𪗳	##
ED74	𪗴	565D
ED76	𪗵	57A7
ED79	𪗶	5234
ED7C	𪗷	**
ED7D	𪗸	9D7C
ED7E	𪗹	7C56
ED7F	𪗺	9B39
ED80	𪗻	57DE
ED82	𪗼	5C53
ED83	𪗽	64D3
ED87	𪗾	86AD
ED8C	𪗿	##
ED8D	𪗠	51FE
ED8F	𪗡	5D8E
ED90	𪗢	9703
ED92	𪗣	9E81
ED93	𪗤	904C
ED94	𪗥	7B1F
ED95	𪗦	9B02
ED96	𪗧	5CD1
ED97	𪗨	7BA3
ED98	𪗩	6268
ED99	𪗪	6335
ED9A	𪗫	9AFF
ED9B	𪗬	7BCF
ED9C	𪗭	9B2A
ED9D	𪗮	7C7E
ED9E	𪗯	**
ED9F	𪗰	7C42
EDA0	𪗱	7C86
EDA1	𪗲	9C15
EDA2	𪗳	7BFC
EDA3	𪗴	9B09
EDA4	𪗵	**
EDA5	𪗶	9C1B
EDA7	𪗷	9F5A
EDA8	𪗸	5573

EDA9	𪗹	5BC3
EDAA	𪗺	4FFD
EDAB	𪗻	9E98
EDAC	𪗼	4FF2
EDAD	𪗽	5260
EDAF	𪗾	52D1
EDB0	𪗿	5767
EDB1	𪗠	5056
EDB2	𪗡	59B7
EDB3	𪗢	5E12
EDB4	𪗣	97C8
EDB5	𪗤	9DAB
EDB6	𪗥	8F5C
EDB7	𪗦	5469
EDB8	𪗧	97B4
EDB9	𪗨	9940
EDBA	𪗩	97BA
EDBB	𪗪	532C
EDBC	𪗫	6130
EDBD	𪗬	692C
EDBE	𪗭	53DA
EDBF	𪗮	9C0A
EDC0	𪗯	9D02
EDC2	𪗰	9641
EDC3	𪗱	6980
EDC4	𪗲	50A6
EDC5	𪗳	7546
EDC7	𪗴	99DA
EDC8	𪗵	5273
EDC9	𪗶	##
EDCA	𪗷	9159
EDCB	𪗸	9681
EDCC	𪗹	915C
EDCD	𪗺	##
EDCE	𪗻	9151
EDD0	𪗼	637F
EDD2	𪗽	6ACA
EDD3	𪗾	5611
EDD4	𪗿	918E
EDD5	𪗠	757A
EDD6	𪗡	6285

EDD8	𪗢	734F
EDD9	𪗣	7C70
EDDC	𪗤	##
EDDE	𪗥	76D6
EDDF	𪗦	9B9D
EDE0	𪗧	4E2A
EDE2	𪗩	83BE
EDE3	𪗪	8842
EDE4	𪗫	##
EDE5	𪗬	5C4A
EDE6	𪗭	69C0
EDE7	𪗮	**
EDE8	𪗯	577A
EDE9	𪗰	521F
EDEA	𪗱	5DF5
EDEB	𪗲	4ECE
EDEC	𪗳	6C31
EDEE	𪗴	4F39
EDEF	𪗵	549C
EDF0	𪗶	54DA
EDF1	𪗷	529A
EDF2	𪗸	8D82
EDF4	𪗹	**
EDF6	𪗺	##
EDF7	𪗻	6B52
EDF8	𪗼	917C
EDF9	𪗽	9FA5
EDFA	𪗾	9B97
EDFB	𪗿	982E
EDFC	𪗠	98B4
EDFD	𪗡	9ABA
EDFE	𪗢	9EA8
EDFF	𪗣	9E84
EE00	𪗤	717A
EE01	𪗥	7B14
EE02	𪗦	##
EE03	𪗧	6BFA
EE04	𪗨	8818
EE05	𪗩	7F78
EE06	𪗪	##
EE07	𪗫	5620

EE09	蹙	8E77
EE0A	亂	9F53
EE0B	繩	##
EE0C	跣	8DD4
EE0D	蹶	8E4F
EE0E	鸚	9E1C
EE0F	蹶	8E01
EE10	狂	6282
EE12	蹶	8E28
EE13	蹙	8E75
EE14	耗	7AD3
EE16	稟	7A3E
EE17	磋	78D8
EE18	泪	6CEA
EE19	奢	8A67
EE1A	瘡	7607
EE1C	詔	9F26
EE1D	詐	6CCE
EE1E	蜥	87D6
EE1F	炫	75C3
EE21	磋	7853
EE23	蹙	8D0C
EE24	貉	72E2
EE25	獮	7371
EE26	謗	8B2D
EE27	猥	7302
EE28	飀	74F1
EE29	賣	8CEB
EE2B	盪	862F
EE2C	僥	5FBA
EE2D	麥	88A0
EE2F	袂	##
EE32	熵	##
EE33	詢	8A7E
EE35	悉	##
EE36	愠	60FD
EE37	瘳	7667
EE38	醴	9AD7
EE39	鷄	9D44
EE3A	鑰	936E
EE3B	鮭	9B8F

EE3C	蝟	87F5
EE3D	癩	##
EE3E	懈	**
EE3F	賣	8CF7
EE40	猜	732C
EE41	露	9721
EE42	鮑	9BB0
EE44	豺	72B2
EE46	糞	7C51
EE47	齧	994A
EE49	慙	6159
EE4B	糜	9E96
EE4C	憾	617D
EE4D	屯	##
EE4E	坟	575F
EE4F	傷	616F
EE50	柄	62A6
EE51	扈	6239
EE52	拾	**
EE54	愴	61E2
EE55	厖	53AA
EE57	搥	6364
EE58	姆	6802
EE5A	歲	5D57
EE5C	迥	8FDA
EE5E	嗽	##
EE5F	僇	50D9
EE61	礮	7906
EE62	隘	5332
EE63	隄	9638
EE66	譽	##
EE67	矾	77FE
EE68	糲	##
EE69	糗	7CC2
EE6B	糲	7CDA
EE6C	稽	7A2D
EE6D	聰	8066
EE6E	睨	8063
EE6F	紕	7D4D
EE70	礮	7505
EE71	醜	74F2

EE72	覓	8994
EE73	擔	821A
EE74	盼	670C
EE75	睨	8062
EE77	睥	805B
EE78	眈	74F0
EE79	脆	8103
EE7A	昵	7724
EE7B	羈	8989
EE7D	沓	7553
EE7F	蝮	87A9
EE80	蝮	87CE
EE81	臆	81C8
EE82	螢	878C
EE83	諷	8A49
EE84	質	8CAD
EE85	謔	8B43
EE86	眸	772B
EE87	逦	74F8
EE88	蔭	84DA
EE8A	楹	69B2
EE8B	趨	8DA6
EE8C	亂	##
EE8D	靚	89A9
EE8E	璫	**
EE8F	淒	6DB9
EE90	蠱	87C1
EE92	趾	74E7
EE94	焜	7176
EE95	愍	60A4
EE96	懣	619C
EE98	梵	**
EE99	恹	6077
EE9A	憊	##
EE9B	鬲	7F71
EE9D	腠	**
EE9E	懲	60E9
EEA0	刪	5220
EEAB	峁	5CC1
EEB3	蟻	5B1F
EEB5	齊	9F50

EEB6	麥	9EA6
F319	Ā	0100
F31A	Ǻ	00C1
F31B	ǻ	01CD
F31C	Ǽ	00C0
F31D	Ē	0112
F31E	É	00C9
F31F	Ë	011A
F320	È	00C8
F321	Ō	014C
F322	Ǫ	00D3
F323	ǫ	01D1
F324	Ǿ	00D2
F326	Ê	1EBE
F328	Ë	1EC0
F329	Ê	00CA
F32A	ā	0101
F32B	ǎ	00E1
F32C	ǎ	01CE
F32D	ǎ	00E0
F32E	ǎ	0251
F32F	ē	0113
F330	é	00E9
F331	ě	011B
F332	è	00E8
F333	ī	012B
F334	ī	00ED
F335	ǐ	01D0
F336	ì	00EC
F337	ō	014D
F338	ó	00F3
F339	ǒ	01D2
F33A	ò	00F2
F33B	ū	016B
F33C	ú	00FA
F33D	ǔ	01D4
F33E	ù	00F9
F33F	ū	01D6
F340	ú	01D8
F341	ǘ	01DA
F342	ü	01DC

F343	ü	00FC
F345	ě	1EBF
F347	è	1EC1
F348	e	00EA
F349	g	0261
F3A3	攪	650A
F3A6	丽	4E3D
F3A7	滝	6EDD
F3A8	鷄	9D4E
F3A9	釵	91DF
F3AD	撑	6491
F3AE	会	4F1A
F3AF	尢	4F28
F3B0	侨	4FA8
F3B1	究	5156
F3B2	兴	5174
F3B3	衣	519C
F3B4	夙	51E4
F3B5	务	52A1
F3B6	动	52A8
F3B7	医	533B
F3B8	华	534E
F3B9	发	53D1
F3BA	变	53D8
F3BB	团	56E2
F3BC	声	58F0
F3BD	处	5904
F3BE	备	5907
F3BF	夆	5932
F3C0	头	5934
F3C1	学	5B66
F3C2	实	5B9E
F3C3	寔	5B9F
F3C4	嵐	5C9A
F3C5	庆	5E86
F3C6	总	603B
F3C7	齐	6589
F3C8	柩	67FE
F3C9	荣	6804
F3CA	桥	6865
F3CB	济	6D4E

F3CC	炼	70BC
F3CD	电	7535
F3CE	纤	7EA4
F3CF	纬	7EAC
F3D0	纺	7EBA
F3D1	织	7EC7
F3D2	经	7ECF
F3D3	统	7EDF
F3D4	纜	7F06
F3D5	郇	7F37
F3D6	艺	827A
F3D7	苏	82CF
F3D8	药	836F
F3D9	视	89C6
F3DA	设	8BBE
F3DB	询	8BE2
F3DC	车	8F66
F3DD	轧	8F67
F3DE	轮	8F6E
F3DF	瑄	7411
F3E0	幼	7CFC
F3E1	緡	7DCD
F3E2	櫻	6946
F3E3	籠	7AC9
F3E4	刼	5227
F3E9	醜	918C
F3EA	颯	78B8
F3EB	酖	915E
F3EC	胼	80BC
F3EE	贗	8D0B
F3EF	胶	80F6
F3F3	肱	809F
F3F4	黠	9EC7
F3F6	鷓	9DC9
F3F7	鷓	9E0C
F3FB	鷓	9E0A
F3FF	浴	6E9A
F400	晒	823E
F401	貳	7519
F404	马	9A6C
F405	骏	9A8F

F406	龙	9F99
F407	褚	7987
F40C	两	4E24
F40D	乾	4E81
F40E	龜	4E80
F40F	尗	4E87
F410	亿	4EBF
F411	佻	4EEB
F412	佻	4F37
F414	偶	4FBD
F416	偕	5003
F417	僂	5088
F41B	卮	5186
F41C	牵	5905
F41D	凜	51DB
F41E	囡	51FC
F41F	办	5205
F420	争	4E89
F421	剡	5279
F422	剡	5290
F423	医	5327
F425	厥	53A9
F427	廠	53B0
F429	参	53C2
F42A	心	5423
F42E	呱	5493
F42F	咭	54A3
F430	咳	54B4
F431	唆	54B9
F432	哇	54D0
F433	覘	54EF
F434	啓	5518
F435	唿	5523
F436	嘞	5528
F438	唿	553F
F43B	噤	55D7
F43E	吟	5525
F443	嘞	5590
F447	蹶	8E46
F44C	睽	777A
F453	擿	64DD

F458	擿	648D
F459	躑	8E7E
F467	鮑	9AB2
F470	鷓	9D6E
F471	嶺	9815
F475	擿	64B4
F476	啞	54E3
F47F	擊	64EA
F482	蹶	8E68
F48A	燧	5873
F492	踞	5579
F499	臆	81AA
F49A	詐	98F5
F49C	擿	6379
F49F	踞	8DC0
F4A0	噤	56A1
F4A1	擿	647C
F4B1	噤	5652
F4B6	余	6C3D
F4C2	粃	7F93
F4D8	擿	6432
F4EA	閻	95AA
F4EB	嘖	54CC
F4EC	芊	82C4
F4ED	喙	55B9
F4F0	齧	9C26
F4F1	齧	9AB6
F4F4	焜	7140
F4F5	腩	816D
F4F6	齧	80EC
F4F7	余	5C1C
F4F9	胎	8134
F4FB	吓	535F
F4FD	醜	91B6
F506	嚙	56AF
F512	婁	5A54
F517	塚	579C
F527	墻	5899
F528	割	5268
F52B	箠	7BB2
F52C	弄	5B68

F52F	鼈	9F27
F531	鱗	9C1F
F532	鰈	9B8D
F535	噓	55FB
F537	噤	5689
F538	丨	4E28
F539	夂	5902
F53C	青	9751
F53E	フ	4E5B
F53F	亻	4EBB
F541	允	5C23
F542	彑	5F51
F543	卩	5FC4
F545	扌	624C
F546	夂	6535
F547	夕	6B7A
F548	彳	6C35
F549	氷	6C3A
F54A	灬	706C
F54B	囟	722B
F54C	斗	4E2C
F54D	彳	72AD
F54F	𠂇	7F52
F550	衤	793B
F551	糸	7CF9
F552	囟	7F53
F557	耂	8002
F558	耂	8080
F55B	卩	535D
F55C	衤	8864
F55D	见	89C1
F55F	丨	8BA0
F560	贝	8D1D
F561	耂	9485
F562	县	9578
F563	长	957F
F564	门	95E8
F566	韦	97E6
F567	页	9875
F568	风	98CE
F569	飞	98DE

F56A	𠂇	9963
F56C	鱼	9C7C
F56D	鸟	9E1F
F56E	黄	9EC4
F56F	齒	6B6F
F570	龜	9F9C
F571	𠂇	4E37
F573	卩	961D
F574	户	6237
F575	钢	94A2
F634	嶮	5D3E
F635	暖	5D48
F636	渣	5D56
F639	窠	5DA4
F63A	嶮	5DB9
F63D	冪	5E42
F63E	厲	5EBD
F63F	弥	5F25
F640	徃	5F83
F645	愆	60D7
F646	博	613D
F647	崢	5CE5
F649	憊	61B7
F64A	懷	61B9
F64B	情	61CF
F64D	戩	622C
F64E	拈	6290
F64F	拈	62E5
F650	撈	6318
F652	噉	56B1
F654	揸	63E2
F655	搥	63FB
F656	揸	6407
F657	揸	645A
F659	揸	64C0
F65A	崕	5D15
F65B	噉	5621
F65C	龟	9F9F
F65E	敦	6586
F660	昨	65FF
F661	晓	6653

F663	唄	6692
F665	腺	6716
F667	杖	67A4
F668	梔	6800
F66A	榮	684A
F66B	栖	6884
F66F	葉	6909
F670	榿	6943
F671	牛	725C
F672	櫛	6964
F673	梓	699F
F674	榿	6985
F676	橐	69D6
F678	窠	6A65
F679	櫟	6A74
F67A	櫛	6A71
F67B	櫛	6A82
F67D	櫛	6A99
F67F	櫛	6AAB
F680	櫛	6AB5
F681	櫛	6AD4
F682	櫛	6AF6
F683	歿	6B81
F684	毀	6BC1
F685	毳	6BEA
F686	泠	6C75
F687	沪	6CAA
F689	迹	6D02
F68A	涿	6D06
F68B	涿	6D26
F68C	滸	6D81
F68E	涿	6DA4
F68F	涿	6DB1
F690	涿	6E15
F691	涿	6E18
F692	温	6E29
F693	淑	6E86
F695	滂	6EBB
F696	滂	6EE2
F697	滚	6EDA
F698	齿	9F7F

F699	滨	6EE8
F69A	滩	6EE9
F69B	溲	6F24
F69C	溲	6F34
F69F	溲	6F81
F6A0	溲	6FBE
F6A3	溲	71B7
F6A4	吞	5C99
F6A6	瀨	702C
F6A8	溲	7050
F6A9	灑	7054
F6AA	灯	706F
F6AB	灿	707F
F6AC	炉	7089
F6B1	①	2460
F6B2	②	2461
F6B3	③	2462
F6B4	④	2463
F6B5	⑤	2464
F6B6	⑥	2465
F6B7	⑦	2466
F6B8	⑧	2467
F6B9	⑨	2468
F6BA	⑩	2469
F6BB	(1)	2474
F6BC	(2)	2475
F6BD	(3)	2476
F6BE	(4)	2477
F6BF	(5)	2478
F6C0	(6)	2479
F6C1	(7)	247A
F6C2	(8)	247B
F6C3	(9)	247C
F6C4	(10)	247D
F6C5	i	2170
F6C6	ii	2171
F6C7	iii	2172
F6C8	iv	2173
F6C9	v	2174
F6CA	vi	2175
F6CB	vii	2176

F6CC	viii	2177
F6CD	ix	2178
F6CE	x	2179
F6CF	ゝ	4E36
F6D0	ヅ	4E3F
F6D1	ヅ	4E85
F6D2	ㄒ	4EA0
F6D3	冂	5182
F6D4	ㄥ	5196
F6D5	ㄣ	51AB
F6D6	ㄣ	52F9
F6D7	匚	5338
F6D8	匚	5369
F6D9	ム	53B6
F6DA	女	590A
F6DB	宀	5B80
F6DC	≡	5DDB
F6DE	广	5E7F
F6E0	ㄣ	5F50
F6E1	ㄣ	5F61
F6E2	支	6534
F6E4	ㄣ	7592
F6E6	彳	8FB5
F6E8	〃	00A8
F6E9	ˆ	02C6
F6EA	ゝ	30FD
F6EB	ゝ	30FE
F6EC	ゝ	309D
F6ED	ゝ	309E
F6F0	々	3005
F6F1	ㄥ	3006
F6F2	○	3007
F6F3	一	30FC
F6F4	[FF3B
F6F5]	FF3D
F6F6	*	273D
F6F7	あ	3041
F6F8	あ	3042
F6F9	い	3043
F6FA	い	3044
F6FB	う	3045

F6FC	う	3046
F6FD	え	3047
F6FE	え	3048
F6FF	お	3049
F700	お	304A
F701	か	304B
F702	が	304C
F703	き	304D
F704	ぎ	304E
F705	く	304F
F706	く	3050
F707	け	3051
F708	げ	3052
F709	こ	3053
F70A	ご	3054
F70B	さ	3055
F70C	ざ	3056
F70D	し	3057
F70E	じ	3058
F70F	ず	3059
F710	ず	305A
F711	せ	305B
F712	ぜ	305C
F713	そ	305D
F714	ぞ	305E
F715	た	305F
F716	だ	3060
F717	ち	3061
F718	ぢ	3062
F719	っ	3063
F71A	っ	3064
F71B	づ	3065
F71C	て	3066
F71D	で	3067
F71E	と	3068
F71F	ど	3069
F720	な	306A
F721	に	306B
F722	ぬ	306C
F723	ね	306D
F724	の	306E

F725	は	306F
F726	ば	3070
F727	ぱ	3071
F728	ひ	3072
F729	び	3073
F72A	び	3074
F72B	ふ	3075
F72C	ぶ	3076
F72D	ぶ	3077
F72E	へ	3078
F72F	べ	3079
F730	ぺ	307A
F731	ほ	307B
F732	ぼ	307C
F733	ぼ	307D
F734	ま	307E
F735	み	307F
F736	む	3080
F737	め	3081
F738	も	3082
F739	や	3083
F73A	や	3084
F73B	ゆ	3085
F73C	ゆ	3086
F73D	よ	3087
F73E	よ	3088
F73F	ら	3089
F740	り	308A
F741	る	308B
F742	れ	308C
F743	ろ	308D
F744	わ	308E
F745	わ	308F
F746	ゐ	3090
F747	ゑ	3091
F748	を	3092
F749	ん	3093
F74A	ア	30A1
F74B	ア	30A2
F74C	イ	30A3
F74D	イ	30A4

F74E	ウ	30A5
F74F	ウ	30A6
F750	エ	30A7
F751	エ	30A8
F752	オ	30A9
F753	オ	30AA
F754	カ	30AB
F755	ガ	30AC
F756	キ	30AD
F757	ギ	30AE
F758	ク	30AF
F759	グ	30B0
F75A	ケ	30B1
F75B	ゲ	30B2
F75C	コ	30B3
F75D	ゴ	30B4
F75E	サ	30B5
F75F	ザ	30B6
F760	シ	30B7
F761	ジ	30B8
F762	ス	30B9
F763	ズ	30BA
F764	セ	30BB
F765	ゼ	30BC
F766	ソ	30BD
F767	ゾ	30BE
F768	タ	30BF
F769	ダ	30C0
F76A	チ	30C1
F76B	ヂ	30C2
F76C	ツ	30C3
F76D	ツ	30C4
F76E	ヅ	30C5
F76F	テ	30C6
F770	デ	30C7
F771	ト	30C8
F772	ド	30C9
F773	ナ	30CA
F774	ニ	30CB
F775	ヌ	30CC
F776	ネ	30CD

F777	ノ	30CE
F778	ハ	30CF
F779	バ	30D0
F77A	パ	30D1
F77B	ヒ	30D2
F77C	ピ	30D3
F77D	ポ	30D4
F77E	プ	30D5
F77F	ブ	30D6
F780	ブ	30D7
F781	ヘ	30D8
F782	ベ	30D9
F783	ペ	30DA
F784	ホ	30DB
F785	ポ	30DC
F786	ボ	30DD
F787	マ	30DE
F788	ミ	30DF
F789	ム	30E0
F78A	メ	30E1
F78B	モ	30E2
F78C	ヤ	30E3
F78D	ヤ	30E4
F78E	ユ	30E5
F78F	ユ	30E6
F790	ヨ	30E7
F791	ヨ	30E8
F792	ラ	30E9
F793	リ	30EA
F794	ル	30EB
F795	レ	30EC
F796	ロ	30ED
F797	ワ	30EE

F798	ワ	30EF
F799	ヰ	30F0
F79A	ヱ	30F1
F79B	ヲ	30F2
F79C	ン	30F3
F79D	ヴ	30F4
F79E	カ	30F5
F79F	ケ	30F6
F7A0	А	0410
F7A1	Б	0411
F7A2	В	0412
F7A3	Г	0413
F7A4	Д	0414
F7A5	Е	0415
F7A6	Ё	0401
F7A7	Ж	0416
F7A8	З	0417
F7A9	И	0418
F7AA	Й	0419
F7AB	К	041A
F7AC	Л	041B
F7AD	М	041C
F7AE	Н	041D
F7AF	О	041E
F7B0	П	041F
F7B1	Р	0420
F7B2	С	0421
F7B3	Т	0422
F7B4	У	0423
F7B5	Ф	0424
F7B6	Х	0425
F7B7	Ц	0426
F7B8	Ч	0427

F7B9	Ш	0428
F7BA	Щ	0429
F7BB	Ъ	042A
F7BC	Ы	042B
F7BD	Ь	042C
F7BE	Э	042D
F7BF	Ю	042E
F7C0	Я	042F
F7C1	а	0430
F7C2	б	0431
F7C3	в	0432
F7C4	г	0433
F7C5	д	0434
F7C6	е	0435
F7C7	ё	0451
F7C8	ж	0436
F7C9	з	0437
F7CA	и	0438
F7CB	й	0439
F7CC	к	043A
F7CD	л	043B
F7CE	м	043C
F7CF	н	043D
F7D0	о	043E
F7D1	п	043F
F7D2	р	0440
F7D3	с	0441
F7D4	т	0442
F7D5	у	0443
F7D6	ф	0444
F7D7	х	0445
F7D8	ц	0446
F7D9	ч	0447

F7DA	ш	0448
F7DB	щ	0449
F7DC	ъ	044A
F7DD	ы	044B
F7DE	ь	044C
F7DF	э	044D
F7E0	ю	044E
F7E1	я	044F
F7E2	ѐ	21E7
F7E3	ё	21B8
F7E4	ђ	21B9
F7E7	Љ	4E5A
F7E9	Њ	5202
F7EC	Ѓ	5188
F817	ѐ	FFE2
F818	ё	FFE4
F819	ђ	FF07
F81A	”	FF02
F81B	株	3231
F81C	№	2116
F81D	Тел	2121
F81E	°	309B
F81F	°	309C
F83F	ѓ	0283
F840	ѳ	0250
F841	ε	025B
F842	Ϸ	0254
F843	ϸ	0275
F844	œ	0153
F845	ø	00F8
F846	η	014B
F847	Ϸ	028A
F848	ı	026A

** To maintain backward compatibility, the corresponding PUA code points in ISO 10646 v1.0 of those unified characters will be reserved.

To maintain backward compatibility, the corresponding PUA code points in ISO 10646 v1.0 of those characters not verifiable will be reserved.

Annex III List of Compatibility Points and Their Corresponding Characters in ISO 10646 v2.0

The following is an example of an entry in this Annex:

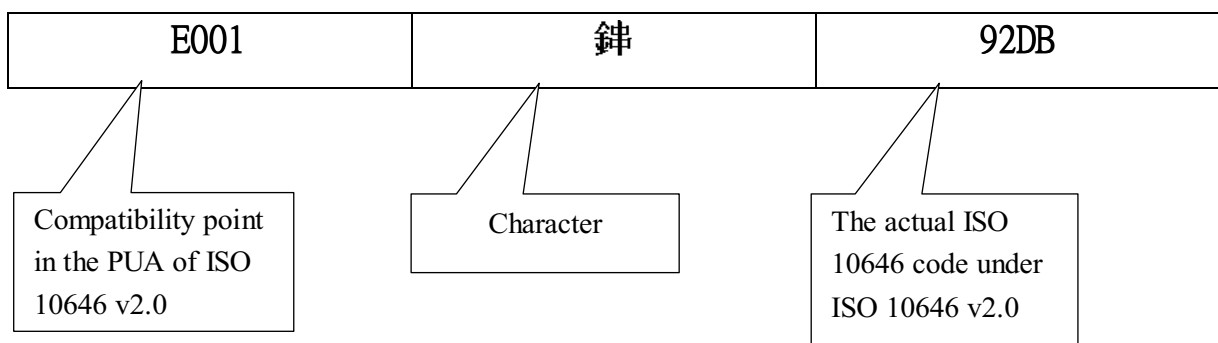

E001	鉷	92DB
E004	藟	854C
E005	紉	42B5
E006	琿	73EF
E007	況	51B5
E008	塤	3649
E00B	鯨	9344
E00D	苜	82EE
E00F	砣	783C
E010	杆	6744
E011	拟	62DF
E017	佞	4FAB
E019	徠	5008
E01F	倩	**
E021	健	5FA4
E024	滌	6EDB
E026	僞	**
E027	僑	5101
E028	僑	347A
E029	儼	510E
E02A	顛	986C
E02B	旒	3743
E02C	莧	8416
E02F	堯	5160
E031	兪	516A
E039	宄	5B82
E03A	蟪	877D
E03D	冲	51B2
E03E	泮	51B8
E03F	鴿	9D34
E040	涼	51C9
E041	減	51CF
E042	湊	51D1
E043	淋	3CDC
E044	凜	51D3
E046	決	51B3
E047	凡	51E2
E048	凡	5342
E049	凭	51ED
E04A	蒼	83CD

E04B	楸	693E
E04D	彻	5F7B
E04E	刊	520B
E04F	刮	5226
E050	劫	523C
E051	券	52B5
E052	剗	5257
E053	劒	5294
E054	効	52B9
E055	勅	52C5
E056	斂	7C15
E057	勝	8542
E058	勳	52E0
E059	勳	860D
E05B	包	**
E05D	唸	5549
E05E	滙	6ED9
E062	匱	5333
E063	什	**
E065	洸	6CCB
E067	協	681B
E068	協	73D5
E069	協	604A
E06A	卦	3EAA
E06B	卦	38CC
E06D	燂	71DD
E06E	茆	44A2
E06F	邛	536D
E070	却	5374
E072	鄂	537E
E073	卿	**
E076	蒺	77E6
E077	厓	5393
E079	厠	53A0
E07A	廩	53AB
E07B	廩	53AE
E07C	坑	73A7
E07E	吮	3F59
E07F	琮	739C
E080	叁	53C1

E081	叁	53C5
E082	汙	6C49
E083	义	4E49
E084	聖	57FE
E085	叙	53D9
E086	斂	3AAB
E088	疊	53E0
E08B	叶	53F6
E08D	吓	5413
E08E	炆	7079
E08F	唸	552B
E090	哈	6657
E091	滄	6D5B
E092	呖	546D
E095	啣	555D
E096	咏	548F
E097	咤	54A4
E098	趁	47A6
E09B	焯	3DB4
E09F	商	5547
E0A0	鵬	4CED
E0A1	旨	542F
E0A2	琫	7417
E0A3	喆	5586
E0A4	喻	55A9
E0A5	嘸	**
E0A8	藹	4552
E0AA	嚳	66B3
E0AC	嘯	5637
E0AD	嘯	66CD
E0AF	嘯	66A4
E0B0	嘯	66AD
E0B1	嚳	564D
E0B2	嚳	564F
E0B3	磅	78F1
E0B4	囪	56F1
E0B5	鞣	9787
E0B6	舌	53FE
E0B7	罨	5700
E0B8	国	56EF

E0B9	园	56ED
E0BB	圃	3623
E0BD	坟	5746
E0BF	沟	6C6E
E0C0	焯	708B
E0C1	坂	5742
E0C2	姪	36B1
E0C4	塤	57E6
E0C6	塹	5803
E0C9	堦	5826
E0CB	塚	585C
E0CC	整	58AA
E0CD	叡	3561
E0CE	壠	58E0
E0CF	壘	58DC
E0D1	壘	58FB
E0D2	寿	5BFF
E0D3	圪	5743
E0D6	鏢	93D3
E0D7	噉	35A1
E0D8	够	591F
E0D9	梦	68A6
E0DA	娶	36C3
E0DB	溲	6E59
E0DD	裝	5A24
E0DE	啓	5553
E0E0	蘭	8505
E0E1	姊	59C9
E0E6	姪	59D9
E0EA	派	6D71
E0ED	姪	59F9
E0EF	媿	5AAB
E0F0	媿	5A63
E0F1	媿	36E6
E0F3	媿	**
E0F4	媿	3708
E0F5	媿	5A96
E0F6	媿	7465
E0F7	媿	5AD3
E0FA	溲	3D85

E0FC	孃	3732
E0FE	広	5E83
E0FF	勛	52D0
E100	孳	5B76
E101	孳	6588
E102	孳	5B7C
E104	盜	4004
E105	輓	485D
E107	寧	5BD5
E108	傲	6160
E10C	寶	5BF3
E10D	宝	5B9D
E10E	鸚	4D10
E10F	尅	5C05
E111	尔	5C13
E112	珎	73CE
E113	尔	5C14
E116	屈	5C49
E117	鄺	48DD
E118	岷	5C85
E119	峩	5CE9
E11A	峩	5CEF
E11B	鳴	5D8B
E11E	崑	5D10
E11F	崑	5D18
E120	崑	5D46
E122	岑	5CBA
E123	巖	5DD7
E124	荏	82FC
E125	荏	382D
E129	芾	8287
E12A	帆	3836
E12B	滯	3BC2
E12C	幫	5E2E
E12D	櫛	6A8A
E12E	秆	**
E12F	么	5E7A
E132	厦	53A6
E133	廉	4EB7
E134	廐	**

E135	厨	53A8
E137	帔	5E09
E138	乚	5EF4
E13A	迫	5EF9
E13B	廻	5EFB
E13C	廻	38A0
E13D	廻	5EFC
E13E	柔	683E
E13F	鐐	941B
E140	式	5F0D
E143	叟	3ADE
E144	遙	48AE
E146	强	5F3A
E149	彘	**
E14B	彘	5F63
E14C	鞞	97BD
E14E	彘	5F72
E14F	錫	9340
E151	徧	5FA7
E152	徧	5DB6
E153	徧	3D5F
E158	鈔	91D6
E15B	忽	6031
E15C	哿	6685
E15E	憲	3963
E15F	斂	3DC7
E160	些	3639
E161	盜	5790
E163	祝	7971
E164	特	3E40
E165	悞	609E
E166	恩	**
E167	惠	60B3
E16B	瓊	74A4
E16C	德	50E1
E16D	媼	5AA0
E16E	慤	6164
E16F	黃	8424
E170	憑	6142
E173	憶	6181

E174	憑	51F4
E176	憇	6187
E177	宪	5BAA
E17A	懷	61D3
E17D	懷	61D0
E17E	恣	3932
E181	恣	6023
E182	慤	615C
E183	攞	651E
E184	抵	638B
E186	担	62C5
E188	扞	62D5
E18A	拊	636C
E18C	捷	3A17
E18D	揅	6438
E18E	揅	63F8
E191	撐	**
E192	溥	6F8A
E194	頓	9814
E197	擡	64E1
E198	擡	64E5
E199	鑄	947B
E19A	攜	3A66
E19B	携	643A
E19C	携	3A57
E19D	斂	654D
E19E	激	6F16
E1A1	斂	6585
E1A2	斂	656D
E1A3	斂	655F
E1A5	斂	65B5
E1A7	斂	4B37
E1A8	旃	65D1
E1A9	磴	40D8
E1AB	无	65E0
E1AC	旣	65E3
E1AD	攸	5FDF
E1AF	舅	6618
E1B2	眺	6644
E1B5	晋	664B

E1B7	皓	6667
E1B9	皙	6673
E1BA	晴	**
E1C0	矚	77C5
E1C2	鵠	99A4
E1C3	勗	6702
E1C6	誓	3B2B
E1C7	糠	69FA
E1C9	杞	**
E1CA	杌	6767
E1CB	杌	6762
E1CE	杌	67D7
E1CF	稜	44E9
E1D0	栢	6822
E1D1	洧	6E50
E1D2	鉞	923C
E1D3	柳	6801
E1D6	桲	685D
E1D8	榛	69E1
E1D9	榭	6A0B
E1DB	煤	6973
E1DC	黎	68C3
E1DE	桴	6901
E1DF	椀	6900
E1E0	漈	3D32
E1E1	揅	3A01
E1E3	榭	3B80
E1E4	枌	67AC
E1E5	榆	6961
E1E7	縵	42FC
E1E8	櫻	6936
E1E9	渠	6998
E1EA	渠	3BA1
E1EC	榮	8363
E1ED	僑	5090
E1EE	棹	69F9
E1F1	櫛	6A45
E1F3	櫛	6A9D
E1F4	櫛	3BF3
E1F5	枱	67B1

E1F6	櫟	6AC8
E1F8	槩	3C0D
E1F9	藪	6B1D
E1FB	愀	60DE
E1FC	欸	6B35
E1FD	歷	6B74
E1FF	激	6EB5
E203	盱	3740
E204	吡	5421
E206	毡	6BE1
E208	毡	6BDC
E209	水	6C37
E20D	污	6C5A
E20E	猷	8226
E20F	涵	6C79
E211	芥	44C5
E217	嬉	36E5
E218	沓	3CEB
E21A	鯀	9B83
E21D	彰	7F8F
E21E	样	6837
E222	泄	6D96
E223	浜	6D5C
E224	滢	6E7C
E225	滢	6F04
E229	菁	8533
E22B	淞	51C7
E22C	洗	**
E22D	渝	**
E22E	箭	842E
E230	港	**
E232	疎	7453
E234	焱	79CC
E235	湏	6E4F
E236	媼	5A91
E238	澹	6FF8
E239	嬉	370D
E23A	溜	6F9D
E23C	滌	6EFA
E23F	蔓	4555

E240	鏞	93F0
E241	漱	6F44
E242	潛	6F5C
E243	澗	3D4E
E244	潛	6F74
E246	澍	3D3B
E247	凜	6F9F
E249	濂	6FD3
E250	瀆	51DF
E255	澆	704B
E256	灾	707E
E257	施	70A7
E258	烝	7081
E259	焮	70CC
E25A	威	70D5
E25B	裁	70D6
E25C	烟	70DF
E25D	裊	4104
E25E	燦	3DE8
E25F	焯	71B4
E260	焯	7196
E262	焯	712B
E263	煨	7145
E264	嬋	5A88
E265	煊	714A
E266	煮	**
E267	岍	5C9C
E269	焜	714F
E26A	錫	9362
E26C	煬	712C
E270	熿	71BA
E272	焮	70BD
E273	熿	720E
E274	鑪	9442
E275	燮	7215
E276	燮	5911
E277	鑪	9443
E278	爛	7224
E279	斂	9341
E27B	虺	722E

E27C	牀	7240
E27E	栳	68BD
E27F	總	7255
E280	牖	7257
E281	羣	3E55
E283	牲	680D
E284	渾	6F3D
E285	犁	7282
E286	猜	**
E287	猫	732B
E28A	猷	48ED
E28C	獾	7328
E28D	猷	732E
E28E	珏	73CF
E28F	玲	73AA
E292	珉	73C9
E293	璫	7449
E297	眈	6623
E298	珥	36C5
E29C	珞	73F7
E29D	琿	7415
E29E	椳	6903
E2A0	棗	7439
E2A2	斐	3ED7
E2A3	瑜	**
E2A5	璫	7460
E2A7	璫	7447
E2A8	璫	73E4
E2A9	璫	7476
E2AA	莹	83B9
E2AB	璫	746C
E2AC	爍	3730
E2AD	穀	7474
E2AE	鐘	93F1
E2AF	櫛	6A2C
E2B0	璫	7482
E2B1	鏹	4953
E2B6	嫫	5B46
E2B9	璫	74C8
E2BB	甄	750E

E2BC	甞	**
E2BD	甞	751E
E2C0	甞	5BD7
E2C2	鐸	9385
E2C3	哢	754D
E2C4	哢	754A
E2C5	畧	7567
E2C6	晦	756E
E2C8	璣	3F04
E2CA	疎	758E
E2CB	璫	745D
E2CC	瘡	759E
E2CD	疴	75B4
E2CE	瘡	7602
E2CF	瘡	762C
E2D0	瘡	7651
E2D1	瘡	764F
E2D2	瘡	766F
E2D3	𠄎	7676
E2D5	阜	7690
E2D6	阜	81EF
E2D7	嶧	37F8
E2DA	皞	76A1
E2DB	皞	76A5
E2DC	鼓	76B7
E2DD	盃	76CC
E2DF	蓋	8462
E2E3	眞	771E
E2E4	眈	7726
E2E5	着	7740
E2E6	擗	64AF
E2E8	冨	7758
E2EA	矚	77AF
E2EE	矚	77F4
E2EF	善	**
E2F2	碁	68CA
E2F3	碁	78AF
E2F4	碁	78C7
E2F5	碁	78D3
E2F6	墮	96A5

E2F7	礮	792E
E2F9	磚	78D7
E2FA	礪	7934
E2FB	碱	78B1
E2FD	迈	8FB8
E2FE	袄	8884
E302	裨	7986
E303	祺	8900
E304	椽	6902
E305	稟	7980
E307	襪	799D
E309	礼	793C
E30A	祺	79A9
E30B	馮	6E2A
E30D	珙	3EA8
E30E	秆	79C6
E310	杭	79D4
E312	埠	57BE
E314	熇	713E
E316	城	364E
E317	椽	69A2
E319	香	5B74
E31A	釋	7A49
E31D	輿	7A65
E31E	穿	7A7D
E320	憲	7ABB
E321	審	7AB0
E322	寮	7AC2
E323	龜	7AC3
E324	燿	71D1
E326	竄	41CA
E327	竚	7ADA
E328	竝	7ADD
E329	豎	7AEA
E32A	管	41EF
E32B	咲	54B2
E32D	笋	7B0B
E32E	符	7B55
E32F	笱	7B29
E332	筍	7BA2

E333	筍	7B6F
E334	筱	839C
E337	籊	7BD0
E338	苕	8421
E339	筍	7B92
E33A	筍	**
E33C	焯	3DAD
E33E	薜	8492
E33F	籊	7BFA
E340	籊	**
E341	籊	7C35
E343	籊	7C44
E344	枇	7C83
E346	舜	7CA6
E347	唻	667D
E349	糗	7CC9
E34A	糗	7CC7
E34B	糗	7CE6
E34C	糗	7C74
E34D	糗	7CF3
E34E	糗	7CF5
E34F	糗	**
E350	糗	7E67
E351	糗	451D
E353	糗	7D5D
E355	糗	748D
E356	糗	7D89
E357	糗	7DAB
E358	糗	7135
E359	糗	7DB3
E35A	糗	**
E35D	糗	7DE4
E35E	糗	3D13
E35F	糗	7DF5
E361	糗	7DE5
E363	糗	**
E366	糗	7E6E
E367	糗	7E92
E368	糗	432B
E369	糗	946C

E36A	繅	7E27
E36B	繅	7F40
E36C	繅	7F41
E36D	繅	7F47
E36E	繅	7936
E370	罵	99E1
E371	羗	7F97
E373	羗	7FA3
E376	羗	455C
E378	羗	4503
E37A	羗	7FFA
E37C	羗	**
E37D	羗	8008
E37E	羗	801D
E37F	羗	**
E380	羗	802F
E383	羗	803B
E384	羗	803C
E385	羗	8061
E387	羗	4989
E38B	羗	6725
E38C	羗	80A7
E38E	羗	8107
E38F	羗	811A
E390	羗	58B0
E392	羗	6C7F
E395	羗	64E7
E397	羗	8218
E399	羗	6A53
E39C	羗	447A
E39D	羗	8229
E3A1	羗	4FF9
E3A3	羗	84E2
E3A4	羗	8362
E3AA	羗	82AA
E3AB	羗	691B
E3AD	羗	41DB
E3AE	羗	854B
E3AF	羗	82D0
E3B0	羗	831A

E3B3	羗	36C1
E3B6	羗	827B
E3B7	羗	82E2
E3B8	羗	8318
E3BE	羗	3DBF
E3BF	羗	831D
E3C0	羗	55EC
E3C1	羗	8385
E3C2	羗	450B
E3C4	羗	83AC
E3C5	羗	**
E3C6	羗	83D3
E3C7	羗	347E
E3C9	羗	6A57
E3CA	羗	855A
E3CB	羗	3496
E3CE	羗	8458
E3D0	羗	8471
E3D1	羗	3DD3
E3D2	羗	44E4
E3D3	羗	6AA7
E3D4	羗	844A
E3D6	羗	7958
E3D7	羗	**
E3DB	羗	84DE
E3DC	羗	**
E3DD	羗	8391
E3DE	羗	44A0
E3DF	羗	8493
E3E0	羗	84E4
E3E2	羗	4240
E3E4	羗	4543
E3E5	羗	8534
E3E6	羗	5AF2
E3E8	羗	4527
E3E9	羗	8573
E3EA	羗	4516
E3EB	羗	67BF
E3EC	羗	8616
E3EF	羗	85C1

E3F1	藜	8602
E3F5	薄	456A
E3F6	蓀	8628
E3F7	琥	3648
E3F9	号	53F7
E3FB	虾	867E
E3FC	蠹	8771
E3FE	蟾	87EE
E400	蟹	87B1
E401	螫	87DA
E402	蟻	880F
E403	蟾	5661
E404	虬	866C
E405	柚	6856
E406	邨	460F
E407	岬	8845
E408	衆	8846
E40C	衛	885E
E40D	袜	889C
E40E	袷	465B
E40F	袴	88B4
E410	袷	88B5
E411	損	63C1
E412	裝	88C5
E413	瞋	7777
E415	霸	8987
E416	羈	898A
E417	覲	**
E418	覲	**
E419	覽	89A7
E41A	覲	89BC
E41C	解	89E7
E41F	諛	8A9C
E420	瞞	7793
E421	銑	91FE
E422	識	8A90
E424	誼	7AE9
E427	諫	4713
E429	燭	717C
E42A	誦	8B0C

E42B	諂	8B1F
E42E	譎	8B3F
E42F	譎	8B4C
E430	磨	8B4D
E431	諳	8AA9
E433	讐	8B90
E434	讐	8B9B
E435	諳	8AAF
E437	衍	4615
E438	衍	884F
E439	穉	8C9B
E43D	嬾	3725
E43F	賒	8CD6
E442	賢	8D12
E443	聰	8D03
E445	贊	8CDB
E446	瀛	705C
E447	贛	8D11
E449	琰	3ED0
E44A	起	**
E44B	趕	8DA9
E44F	椿	3B7C
E452	娉	7AE7
E453	航	8EAD
E454	躲	8EB6
E455	躡	8EC3
E456	鏡	92D4
E457	輒	8F19
E458	輒	8F2D
E45B	辭	8FA5
E45C	鑿	9303
E45F	麓	8FB3
E460	錄	492A
E464	廸	5EF8
E466	迹	8FF9
E46B	慳	3980
E46D	邊	9037
E470	邈	9061
E473	邨	90A8
E475	邨	90C4

E477	郵	90AE
E478	都	**
E479	酌	9167
E47A	暇	3AF0
E47B	醴	91A9
E47C	醴	91C4
E47D	糶	7CAC
E480	鈎	920E
E481	沟	6C9F
E482	鈇	9241
E483	鉢	9262
E485	鏽	**
E48B	鍊	932C
E48C	鏊	936B
E48F	炊	708F
E490	嬪	5AC3
E493	鎌	4965
E494	鉄	9244
E498	鑒	9373
E499	鑛	945B
E49A	駝	8EBC
E49B	閉	9585
E49C	悶	95A6
E49D	鏞	9426
E49E	閩	95A0
E49F	濶	6FF6
E4A0	紆	42B9
E4A5	陷	49DF
E4A6	氘	6C1C
E4A7	陞	967B
E4A8	隴	9696
E4A9	楹	416C
E4AA	隣	96A3
E4AC	儼	61DA
E4AD	隶	96B6
E4AE	磳	78F5
E4B0	隼	96BD
E4B1	双	53CC
E4B2	閭	49A1
E4BB	霽	9731

E4BC	霧	8642
E4BD	霧	9736
E4BE	霰	4A0F
E4BF	蕩	453D
E4C0	靈	4585
E4C2	靈	7075
E4C3	靈	5B41
E4C4	霽	971B
E4C5	靜	**
E4C7	靛	9757
E4C8	嬪	5B4A
E4CA	鞏	975F
E4CB	鎔	9425
E4CC	僭	50D0
E4CF	鞞	9789
E4D0	鞞	979F
E4D1	鞞	97B1
E4D2	鞞	97BE
E4D3	鞞	97C0
E4D4	鞞	97D2
E4D5	鞞	97E0
E4D7	蕤	97EE
E4D8	球	741C
E4DA	響	**
E4DB	韻	97F5
E4DE	韻	4AD1
E4DF	韻	9834
E4E0	頰	9833
E4E1	頰	984B
E4E2	頰	9866
E4E3	晷	3B0E
E4E5	瀆	3D51
E4E9	颯	98CA
E4EA	颯	98B7
E4EB	颯	98C8
E4EC	颯	98C7
E4ED	颯	4AFF
E4F0	喰	55B0
E4F1	喰	98E1
E4F2	飡	98E6

E4F3	養	98EC
E4F4	鋤	9378
E4F5	齧	9939
E4F7	騎	4B72
E4FA	駟	99F5
E4FB	駟	9A0C
E4FC	駟	9A3B
E4FD	駟	9A10
E4FE	羸	9A58
E500	娥	36C4
E503	髡	9AE0
E504	髡	9AE2
E506	髡	9AF4
E507	髡	4C0E
E508	髡	9B14
E509	鬪	9B2D
E50B	倭	5034
E50C	黼	9B34
E50E	黼	38C3
E510	黼	9B50
E511	黼	9B40
E513	媼	5A45
E515	鮎	9B8E
E517	鯽	9C02
E518	鯽	9BFF
E519	鯽	9C0C
E51B	鯽	9DD4
E522	鴟	9D7E
E523	駝	9D83
E525	鸞	9E0E
E526	梲	6888
E527	鷄	9DC4
E52D	鴉	9D39
E530	磨	9E90
E531	磨	9E95
E532	磨	9E9E
E533	磨	9EA2
E534	麩	4D34
E535	麩	9EAA
E536	麩	9EAF

E538	磨	9EC1
E539	栲	3B60
E53A	栲	39E5
E53B	梨	3D1D
E53C	侏	4F32
E53D	岬	37BE
E53F	鼉	9F02
E540	鼉	9F08
E541	駟	4B96
E542	鑼	9424
E544	蠶	9F17
E545	蠶	**
E546	蠶	9F39
E547	嚙	569F
E548	嚙	568A
E549	駟	9F45
E54A	駟	99B8
E54C	蠶	97F2
E54D	層	847F
E54E	齡	9F62
E54F	齡	9F69
E550	竜	7ADC
E551	龐	9F8E
E552	癩	7216
E553	驢	4BBE
E556	燒	7177
E55A	玦	739E
E55D	襠	799F
E560	錯	9369
E561	錯	93F3
E563	鏊	92EC
E564	鄒	9381
E565	鏊	93CB
E568	燻	7217
E569	瑋	3EEB
E56A	瞿	7772
E56B	榕	7A43
E56C	焯	70D0
E56F	熨	717E
E571	灼	70A3

E574	玲	3EC7
E578	嫵	3722
E57B	媵	36E1
E57F	媵	3723
E581	坛	575B
E587	彊	8503
E589	彊	**
E58A	苻	8455
E591	蕘	44F4
E595	柿	67F9
E596	孃	3733
E597	樓	3C15
E598	塬	3DE7
E599	塬	586C
E59B	咏	6810
E59C	瞠	4057
E5A2	哧	54CB
E5A3	轟	569E
E5A5	噤	5692
E5A9	鑊	93C6
E5AB	鑊	939C
E5AC	沃	4EF8
E5AD	儻	512B
E5AE	嶮	3819
E5B0	△	4EBC
E5B3	侶	4F4B
E5B4	佻	4F8A
E5B6	媼	5A68
E5B9	懣	3999
E5BC	仔	3435
E5BD	仗	4F29
E5C1	錠	8ADA
E5C3	亘	4E98
E5C4	働	50CD
E5C5	僂	510D
E5C6	僂	4FA2
E5C7	仔	4F03
E5CA	征	4F42
E5CB	僂	502E
E5CC	僂	506C

E5CD	僂	5081
E5CE	僂	4FCC
E5CF	僂	4FE5
E5D0	僂	5058
E5D1	僂	50FC
E5D2	尅	**
E5D3	尅	**
E5D4	尅	**
E5D5	尅	**
E5D6	淥	6E76
E5DA	淥	6D72
E5DD	富	51A8
E5DE	涂	51C3
E5E0	盞	44DD
E5E4	趁	8D7A
E5E7	矜	5259
E5E8	矜	52A4
E5EA	勳	52E1
E5EB	鑰	**
E5EC	煨	467A
E5ED	潤	718C
E5F2	罨	69D1
E5F4	臻	**
E5F5	瑯	3EDE
E5F6	璋	7499
E5F7	琿	7414
E5F8	瑕	7456
E5F9	玳	7398
E5FA	駟	4B8E
E5FD	爰	53D0
E5FE	咄	3584
E5FF	燻	720F
E601	喊	55B4
E603	响	54CD
E605	鬪	571D
E606	鉸	925D
E607	壘	96F4
E608	鑊	9366
E609	埕	57DD
E60A	埕	578D

E60B	埶	577F
E60C	埶	363E
E60D	墻	58CB
E60E	媵	5A99
E613	媵	5A2C
E614	媵	59B8
E615	媵	928F
E616	媵	5A7E
E617	媵	5ACF
E618	媵	5A12
E61D	媵	36F5
E61E	媵	6D05
E61F	媵	7443
E620	媵	5A21
E622	媵	5A81
E625	媵	93E0
E626	媵	748C
E628	媵	7105
E629	媵	4972
E62A	媵	9408
E62C	媵	93BD
E62D	媵	37A0
E62E	媵	5C1E
E62F	媵	5C9E
E630	媵	5E5E
E631	媵	5E48
E635	媵	5ECD
E636	媵	5B4F
E639	媵	3701
E63B	媵	36DD
E63D	媵	36D3
E63E	媵	812A
E643	媵	5F0C
E644	媵	5F0E
E647	媵	5A6B
E649	媵	5B44
E64A	媵	8614
E64C	媵	8860
E64D	媵	607E
E650	媵	5FDB

E651	媵	3EB8
E656	媵	61C0
E65A	媵	6199
E65B	媵	6198
E65C	媵	6075
E661	媵	6471
E664	媵	3A29
E669	媵	6337
E66B	媵	64B6
E66C	媵	6331
E66D	媵	63D1
E670	媵	62A4
E672	媵	643B
E673	媵	656B
E674	媵	6972
E675	媵	3BF4
E67A	媵	550D
E67E	媵	66CE
E681	媵	3AE0
E682	媵	4190
E689	媵	78EE
E68D	媵	3464
E691	媵	668E
E693	媵	666B
E694	媵	4B93
E695	媵	6630
E698	媵	6663
E69B	媵	661E
E69D	媵	38D1
E6A0	媵	3B99
E6A3	媵	74D0
E6A4	媵	3B96
E6A5	媵	678F
E6A7	媵	68B6
E6A8	媵	681E
E6A9	媵	3BC4
E6AA	媵	6ABE
E6AB	媵	3863
E6AE	媵	6A33
E6AF	媵	6A52

E6B0	媵	6AC9
E6B1	媵	6B05
E6B3	媵	6511
E6B4	媵	6898
E6B5	媵	6A4C
E6B6	媵	3BD7
E6B7	媵	6A7A
E6B8	媵	6B57
E6BB	媵	93A0
E6BC	媵	92F2
E6BF	媵	9289
E6C2	媵	9467
E6C3	媵	6DA5
E6C4	媵	6F0B
E6C6	媵	**
E6C8	媵	3D8F
E6C9	媵	6E04
E6CB	媵	5A3D
E6CC	媵	6E0A
E6CD	媵	5847
E6CE	媵	6D24
E6CF	媵	7842
E6D0	媵	713B
E6D3	媵	70F1
E6D4	媵	7250
E6D5	媵	7287
E6D6	媵	7294
E6D9	媵	5179
E6DC	媵	747A
E6E2	媵	3F06
E6E3	媵	3EB1
E6E7	媵	60A7
E6E8	媵	3EF3
E6E9	媵	74CC
E6EA	媵	743C
E6EB	媵	9387
E6EC	媵	7437
E6ED	媵	449F
E6EF	媵	4551
E6F0	媵	7583

E6F1	媵	3F63
E6F4	媵	3F58
E6F5	媵	7555
E6F6	媵	7673
E6F8	媵	3B19
E6F9	媵	7468
E6FD	媵	3AFB
E6FE	媵	3DCD
E700	媵	3EFF
E703	媵	91FA
E704	媵	5732
E705	媵	9342
E708	媵	50DF
E70B	媵	7778
E70D	媵	770E
E70E	媵	770F
E70F	媵	777B
E712	媵	3A5E
E714	媵	7438
E715	媵	749B
E716	媵	3EBF
E719	媵	40C8
E71C	媵	9307
E71E	媵	781E
E71F	媵	788D
E720	媵	7888
E721	媵	78D2
E722	媵	73D0
E723	媵	7959
E726	媵	410E
E727	媵	**
E728	媵	8496
E729	媵	79A5
E72A	媵	6A2D
E72C	媵	7A3A
E72D	媵	79F4
E72E	媵	416E
E730	媵	4132
E731	媵	9235
E732	媵	79F1

E738	啐	3597
E739	嗜	556B
E73A	吒	3570
E73B	蚝	36AA
E73E	娒	7AE2
E73F	娒	5A59
E743	娒	5A0D
E745	娒	78F0
E746	娒	5A2A
E748	筊	7AFE
E749	筊	41F9
E74A	籊	7C5D
E74B	籊	7C6D
E74C	籊	4211
E750	糞	7CCD
E753	糞	7C8E
E754	糞	7C7C
E755	糞	7CAE
E756	糞	6AB2
E757	糞	7DDC
E758	糞	7E07
E759	糞	7DD3
E75A	糞	7F4E
E75E	糞	7D97
E760	糞	426A
E763	糞	67D6
E766	糞	57C4
E76A	糞	7FDD
E76B	糞	7B27
E76F	糞	7B0C
E771	糞	99E6
E772	糞	8645
E773	糞	9A63
E774	糞	6A1C
E776	糞	39E2
E779	糞	9A1F
E77B	糞	8480
E77E	糞	44EA
E77F	糞	8137
E780	糞	4402

E781	胆	80C6
E782	脉	8109
E783	脉	8142
E785	脉	98C3
E787	脉	8262
E788	脉	8265
E78A	脉	8453
E78C	脉	8610
E78E	脉	5A86
E78F	脉	417F
E791	脉	5B2B
E793	脉	5AE4
E795	脉	86A0
E798	脉	882D
E79A	脉	5A02
E79B	脉	886E
E79C	脉	4F45
E79D	脉	8887
E79E	脉	88BF
E79F	脉	88E6
E7A0	脉	8965
E7A1	脉	894D
E7A3	脉	8954
E7AA	脉	3EAD
E7AB	脉	84A3
E7AC	脉	46F5
E7AD	脉	46CF
E7AE	脉	37F2
E7AF	脉	8A3D
E7B0	脉	8A1C
E7B2	脉	5F4D
E7B3	脉	922B
E7B5	脉	65D4
E7B6	脉	7129
E7B7	脉	70C4
E7B9	脉	9D6D
E7BA	脉	8C9F
E7BB	脉	8CE9
E7BD	脉	599A
E7BE	脉	77C3

E7BF	娟	59F0
E7C0	玅	436E
E7C1	玅	36D4
E7C2	踪	8E2A
E7C3	躡	8EA7
E7C5	暢	8F30
E7C6	暢	8F4A
E7C7	綵	42F4
E7C8	汗	6C58
E7C9	澁	6FBB
E7CB	澁	489B
E7CC	澁	6F79
E7CD	澁	6E8B
E7CF	輪	9BE9
E7D0	終	36B5
E7D2	邛	90BB
E7D3	邛	**
E7D4	喏	5571
E7D5	醜	4906
E7D6	醜	91BB
E7D7	鑽	9404
E7D9	璇	4062
E7DB	鑽	9427
E7DE	蓋	84E5
E7DF	訖	8A2B
E7E0	閏	9599
E7E1	閏	95A7
E7E2	閏	9597
E7E3	閏	9596
E7E5	璉	7445
E7E6	璉	3EC2
E7EA	璉	3EE7
E7EC	隨	968F
E7F0	琮	3ECC
E7F4	瑋	7412
E7F5	瑋	746B
E7F6	瑋	3EFC
E7F7	璽	9741
E7F9	架	6847
E7FA	霽	4A1D

E7FD	齏	**
E7FE	鏌	9368
E803	鑿	92BA
E804	孃	5B11
E805	諶	8B69
E806	錄	493C
E807	城	73F9
E809	轄	979B
E80A	軻	9771
E80B	鑿	9938
E80D	嶠	5DC1
E810	頤	981F
E812	鏡	92F6
E814	鈔	91E5
E815	菩	44C0
E819	黼	98DC
E81B	璉	3F00
E81C	鉅	922A
E81D	鏡	4925
E81E	菴	8414
E81F	齏	993B
E820	齏	994D
E822	燔	3DFD
E823	馘	999B
E824	馘	4B6F
E825	馘	99AA
E826	驛	9A5C
E829	櫟	6A8F
E82A	驛	9A21
E82B	嬌	5AFE
E82C	驍	9A2F
E82E	駟	4B90
E830	駁	99BC
E831	驪	4BBD
E832	驪	4B97
E833	鑄	937D
E834	場	5872
E836	塚	5822
E839	砒	7844
E83C	樣	68C5

E83D	澗	3D7D
E83E	鑷	9458
E83F	恬	3927
E840	愆	6150
E843	悵	6107
E844	鱣	9C4F
E845	鱣	9C53
E846	鱣	9C7B
E847	鱣	9C35
E848	鱣	9C10
E849	鯨	9B7F
E84A	鯨	9BCF
E84C	鯨	9B9F
E84F	鵠	9D21
E850	鵠	4CAE
E852	鵠	9E18
E853	鵠	4CB0
E854	鵠	9D0C
E859	鵠	9DA5
E85A	鵠	84BD
E85E	鵠	85FC
E85F	鵠	4533
E863	萌	8420
E864	蘊	85EE
E868	矜	79E2
E86B	銜	492D
E86D	潘	3D62
E86E	錦	93DB
E86F	錄	92BE
E870	鏃	9348
E872	瑄	78B9
E873	銜	9277
E874	嬰	944D
E875	倂	4FE4
E876	伏	3440
E877	邁	9064
E879	礪	783D
E87A	礪	7854
E87B	礪	78B6
E87C	礪	784B

E880	吝	369A
E881	侖	4F72
E882	澗	6FDA
E883	澗	6FD9
E884	澗	**
E885	澗	701E
E886	咄	5414
E888	垠	57BB
E889	壳	58F3
E88A	垠	578A
E88B	鷗	9D16
E88C	埒	57D7
E88D	焞	7134
E88E	燁	34AF
E890	嫌	71EB
E893	嫫	**
E896	悞	610C
E897	娉	5ACE
E898	娟	5A0B
E899	紕	42BC
E89B	嬾	372C
E89C	駢	4B7B
E89E	鑰	93BB
E89F	鑄	93B8
E8A2	蕞	8472
E8A8	舫	5994
E8AB	棋	7DA8
E8B1	錕	92E5
E8B2	琅	73E2
E8B3	璣	3EE9
E8B4	璣	74B4
E8B7	璣	3EE1
E8B9	櫟	6AD8
E8BA	琰	73F3
E8BB	璣	73FB
E8BC	璣	3ED6
E8C4	璣	7448
E8C6	焯	70A5
E8C8	鉤	9284
E8C9	珣	73E6

E8CA	鐳	935F
E8CC	鑫	9331
E8CF	鎊	9386
E8D2	銜	4935
E8D4	燧	716B
E8D7	燧	56A4
E8DB	咂	5502
E8DC	籽	79C4
E8DE	纏	7DFE
E8E2	薪	452E
E8E3	斲	9401
E8E4	嫵	370A
E8E7	姪	59B0
E8EB	嫵	5AA1
E8EC	姪	36E2
E8EE	姪	36B0
E8EF	鈺	925F
E8F0	嫵	5A79
E8F3	銜	9374
E8F4	沛	3CCD
E8F6	馥	4A96
E8F7	憚	398A
E8F8	憚	50F4
E8F9	藻	3D69
E8FA	滙	3D4C
E8FC	燭	7175
E8FD	綉	42FB
E8FF	濤	6E0F
E901	萁	44EB
E902	球	6D57
E904	灑	7067
E905	峇	6CAF
E906	浓	3CD6
E909	漫	6E02
E90A	滙	6F0C
E90B	瀾	3D6F
E90D	焜	7551
E90E	姍	36BC
E90F	沔	34C8
E910	靚	4680

E911	珊	3EDA
E912	輻	4871
E913	娠	59C4
E914	鉅	926E
E915	鎔	493E
E916	輻	8F41
E919	垠	5812
E91A	垠	57C8
E91B	媵	36D6
E91D	鎔	70FE
E923	槓	68B9
E924	槓	6967
E92D	槓	6A1A
E930	蓋	843E
E931	萑	44DF
E932	葑	44CE
E937	漣	6F17
E939	葑	833D
E93B	落	83ED
E93F	妣	5989
E940	娣	5A82
E942	姝	5A61
E943	嫵	5A71
E946	嫵	372D
E947	姚	59EF
E949	姪	36C7
E94A	焜	718E
E94B	錕	9390
E94C	燭	669A
E94E	媵	5A6E
E94F	媵	5A2B
E951	櫟	6A2B
E956	焜	711D
E959	倂	4FB0
E95B	嶸	5CC2
E95F	檣	6A0C
E962	焜	70A6
E963	焜	7133
E965	焜	3DA5
E966	滙	6CDF

E969	縉	7E65
E96A	姬	59EB
E96B	嶮	5D2F
E96C	穰	3DF3
E96D	彝	5F5C
E970	縶	7DA4
E971	縶	8426
E972	音	5485
E976	圻	577E
E979	確	3FE5
E97C	湯	7003
E97E	嶮	5D70
E97F	玊	738F
E980	穀	7CD3
E983	佹	4FC8
E984	韻	7FE7
E985	狍	72CD
E986	狍	7310
E988	狍	7338
E989	狍	7339
E98B	狍	7341
E98C	狍	7348
E98D	玊	3EA9
E98F	邈	906C
E990	燧	71F5
E992	琴	73E1
E993	銜	81F6
E994	琬	3ECA
E995	帛	770C
E996	琿	3ED1
E997	沢	6CA2
E998	国	56FD
E999	域	7419
E99A	盟	741E
E99B	璫	741F
E99C	璫	3EE2
E99D	璫	3EF0
E99E	璫	3EF4
E99F	璫	3EFA
E9A0	璫	74D3

E9A1	縶	3F0E
E9A2	縶	3F53
E9A3	吹	7542
E9A4	唳	756D
E9A5	畜	7572
E9A6	登	758D
E9A7	痲	3F7C
E9A8	痲	75C8
E9A9	痲	75DC
E9AA	痲	3FC0
E9AB	痲	764D
E9AC	痲	3FD7
E9AD	痲	7674
E9AE	痲	3FDC
E9AF	癸	767A
E9B1	熙	7188
E9B2	嘯	5623
E9B3	西	8980
E9B4	塩	5869
E9B5	眦	401D
E9B6	睽	7743
E9B7	睽	4039
E9B8	条	6761
E9B9	瞞	4045
E9BA	嘆	35DB
E9BB	瞞	7798
E9BC	瞞	406A
E9BD	瞞	406F
E9BE	属	5C5E
E9BF	墨	77BE
E9C0	瞞	77CB
E9C1	壳	58F2
E9C2	砵	7818
E9C3	点	70B9
E9C4	砵	781C
E9C5	斫	40A8
E9C6	砵	7839
E9C7	砵	7847
E9C8	砵	7851
E9C9	砵	7866

E9CA	葉	8448
E9CC	磨	7933
E9CD	枋	6803
E9CE	礮	7932
E9CF	袂	4103
E9D0	襪	4109
E9D1	襪	7991
E9D2	襪	7999
E9D3	辻	8FBB
E9D4	稭	7A06
E9D5	込	8FBC
E9D6	稽	4167
E9D7	窑	7A91
E9D8	窳	41B2
E9D9	窳	7ABC
E9DA	彳	8279
E9DB	竝	41C4
E9DC	奸	7ACF
E9DD	岭	7ADB
E9DE	醇	41CF
E9DF	両	4E21
E9E0	箬	7B62
E9E1	箬	7B6C
E9E2	篔	7B7B
E9E3	篔	7C12
E9E4	箬	7C1B
E9E5	箬	4260
E9E6	糶	427A
E9E7	糶	7C7B
E9E8	糶	7C9C
E9E9	糶	428C
E9EA	糶	7CB8
E9EB	糶	4294
E9EC	糶	7CED
E9ED	輸	8F93
E9EE	焯	70C0
E9F0	縶	7DCF
E9F1	縶	7DD4
E9F2	縶	7DD0
E9F3	縶	7DFD

E9F4	羹	7FAE
E9F5	羹	7FB4
E9F6	鞏	729F
E9F7	翻	4397
E9F8	給	8020
E9F9	稍	8025
E9FA	筮	7B39
E9FB	榜	802E
E9FC	縶	8031
E9FD	联	8054
E9FE	婦	3DCC
E9FF	垢	57B4
EA00	焯	70A0
EA01	歆	80B7
EA02	肱	80E9
EA03	肱	43ED
EA04	肱	810C
EA05	猪	732A
EA06	肱	810E
EA07	肱	8112
EA08	肱	7560
EA09	齧	8114
EA0A	豚	4401
EA0B	豚	3B39
EA0C	肱	8156
EA0D	肱	8159
EA0E	肱	815A
EA0F	肱	4413
EA10	堺	583A
EA11	肱	817C
EA12	腹	8184
EA13	肱	4425
EA14	肱	8193
EA15	肱	442D
EA16	齧	81A5
EA17	掩	57EF
EA18	肱	81C1
EA19	馭	81E4
EA1A	艘	8254
EA1B	艷	448F

EA1C	芦	82A6
EA1D	艷	8276
EA1E	芎	82CA
EA1F	苧	82D8
EA20	茱	82FF
EA21	茺	44B0
EA22	茂	8357
EA23	險	9669
EA24	柗	698A
EA25	瞽	8405
EA26	灼	70F5
EA27	葑	8464
EA28	葱	60E3
EA29	瞽	8488
EA2A	葑	4504
EA2B	莖	84BE
EA2C	葑	84E1
EA2D	葑	84F8
EA2E	藹	8510
EA2F	菟	8538
EA30	蕒	8552
EA31	藪	453B
EA32	蔭	856F
EA33	蔭	8570
EA34	藪	85E0
EA35	藪	4577
EA36	蚶	8672
EA37	蚶	8692
EA38	蚶	86B2
EA39	蚶	86EF
EA3A	际	9645
EA3B	蝮	878B
EA3C	蟻	4606
EA3D	衛	4617
EA3E	祢	88AE
EA3F	椅	88FF
EA40	襖	8924
EA41	襖	8947
EA42	覬	8991
EA44	誦	8A29

EA45	詠	8A38
EA46	誕	8A94
EA47	諒	8AB4
EA48	豈	8C51
EA49	賔	8CD4
EA4A	賈	8CF2
EA4B	贓	8D1C
EA4C	趁	4798
EA4D	莖	585F
EA4E	跃	8DC3
EA4F	昨	47ED
EA50	佞	4EEE
EA51	隄	8E3A
EA52	嘆	55D8
EA53	坌	5754
EA54	躡	8E71
EA55	噏	55F5
EA56	躡	8EB0
EA57	桃	4837
EA58	害	8ECE
EA59	轉	8EE2
EA5A	軫	8EE4
EA5B	軛	8EED
EA5C	帖	8EF2
EA5D	疋	8FB7
EA5E	迂	8FC1
EA5F	迓	8FCA
EA60	迓	8FCC
EA61	迓	9033
EA62	馱	99C4
EA63	遠	48AD
EA64	食	98E0
EA65	鈺	9213
EA66	鈺	491E
EA67	鈺	9228
EA68	絳	9258
EA69	鉤	926B
EA6A	錦	92B1
EA6B	銜	92AE
EA6C	鋪	92BF

EA6D	鄧	92E3
EA6E	璽	92EB
EA6F	鑄	92F3
EA70	銳	92F4
EA71	錫	92FD
EA72	總	9343
EA73	銀	9384
EA74	鎮	93AD
EA75	璽	4945
EA76	鏤	4951
EA77	磨	9EBF
EA78	鋪	9417
EA79	匆	5301
EA7A	鏹	941D
EA7B	鏤	942D
EA7C	鑿	943E
EA7D	鏹	496A
EA7E	鏹	9454
EA7F	鏹	9479
EA80	錠	952D
EA81	閔	95A2
EA82	閔	49A7
EA83	间	95F4
EA84	阳	9633
EA85	隱	49E5
EA86	杵	67A0
EA87	靈	4A24
EA88	靈	9740
EA89	靈	4A35
EA8A	鞞	97B2
EA8B	鞞	97C2
EA8C	噫	5654
EA8D	顛	4AE4
EA8E	慘	60E8
EA8F	颯	98B9
EA90	颯	4B19
EA91	殮	98F1
EA92	垆	5844
EA93	饒	990E
EA94	饒	9919

EA95	冚	51B4
EA96	餽	991C
EA97	餽	9937
EA98	餽	9942
EA99	餽	995D
EA9A	饜	9962
EA9B	餽	4B70
EA9C	馱	99C5
EA9D	馱	4B9D
EA9E	馱	9A3C
EA9F	馱	9B0F
EAA0	竊	7A83
EAA1	鮪	9B69
EAA2	鮫	9B81
EAA3	鮪	9BDD
EAA4	鮪	9BF1
EAA5	鮪	9BF4
EAA6	鮪	4C6D
EAA7	鮪	9C20
EAA8	審	376F
EAAA	鳶	9D49
EAAB	鰲	9C3A
EAAC	鰲	9EFE
EAAD	鰲	5650
EAAE	鰲	9D93
EAAF	鰲	9DBD
EAB0	鰲	9DC0
EAB1	鰲	9DFC
EAB2	銀	94F6
EAB3	銀	8FB6
EAB4	鱗	9E7B
EAB5	菱	9EAC
EAB6	蒲	9EB1
EAB7	麼	9EBD
EAB8	鯪	9EC6
EAB9	銅	94DC
EABA	駿	9EE2
EABB	騰	9EF1
EABC	騰	9EF8
EABD	竈	7AC8

EABE	𩚑	9F44
EAC2	櫛	691A
EAC3	鈴	94C3
EAC4	妬	59AC
EAC6	𦉳	5840
EAC7	鉄	94C1
EAC8	岻	37B9
EACD	块	5757
EACE	焗	7173
EAD2	呪	546A
EAD5	呀	549E
EADB	惧	60E7
EADD	噤	567A
EAE4	楸	6955
EAE5	𩚑	9C2F
EAE6	𩚑	87A5
EAED	𩚑	5C20
EAEF	𩚑	5E0B
EAF3	𩚑	671E
EAF7	𩚑	3647
E AFC	𩚑	5364
EAFD	𩚑	84AD
EB01	𩚑	8B81
EB06	𩚑	4E78
EB07	𩚑	70BB
EB10	𩚑	62C3
EB13	𩚑	7198
EB14	𩚑	6855
EB16	𩚑	69E9
EB17	𩚑	36C8
EB1E	𩚑	82FD
EB22	𩚑	89A5
EB24	𩚑	8FA0
EB26	𩚑	97B8
EB28	𩚑	9847
EB29	𩚑	9ABD
EB3A	𩚑	5FB1
EB3B	𩚑	6648
EB3C	𩚑	66BF
EB40	𩚑	**

EB42	𩚑	**
EB45	𩚑	**
EB47	𩚑	58B5
EB48	𩚑	670E
EB49	𩚑	6918
EB51	𩚑	48D0
EB52	𩚑	4AB8
EB5C	𩚑	51D2
EB5E	𩚑	599F
EB60	𩚑	3BBE
EB64	𩚑	5788
EB66	𩚑	399B
EB6A	𩚑	3762
EB6C	𩚑	8B5E
EB6E	𩚑	**
EB72	𩚑	7209
EB75	𩚑	5965
EB79	𩚑	8EDA
EB7B	𩚑	528F
EB7C	𩚑	573F
EB7D	𩚑	7171
EB82	𩚑	55BC
EB86	𩚑	**
EB87	𩚑	3473
EB8B	𩚑	4718
EB91	𩚑	5066
EB92	𩚑	34FB
EB94	𩚑	**
EB96	𩚑	477C
EB9C	𩚑	57A1
EB9D	𩚑	7151
EB9E	𩚑	**
EBA1	𩚑	9056
EBA4	𩚑	8B62
EBA7	𩚑	5D5B
EBA9	𩚑	**
EBAC	𩚑	8AEA
EBB1	𩚑	4BC0
EBB5	𩚑	9465
EBB7	𩚑	6195

EBB8	𩚑	5A27
EBBA	𩚑	**
EBBB	𩚑	56B9
EBBE	𩚑	4E6A
EBC0	𩚑	9656
EBC1	𩚑	6D8F
EBC3	𩚑	3618
EBC4	𩚑	8977
EBC9	𩚑	**
EBCB	𩚑	7B42
EBCF	𩚑	**
EBD1	𩚑	7A45
EBD2	𩚑	**
EBD4	𩚑	9A26
EBD6	𩚑	365F
EBD9	𩚑	7983
EBDC	𩚑	5D2C
EBDE	𩚑	**
EBE0	𩚑	46D0
EBE2	𩚑	753B
EBE3	𩚑	8865
EBE5	𩚑	58B6
EBE6	𩚑	371C
EBEA	𩚑	3C54
EBED	𩚑	9281
EBF0	𩚑	9330
EBF3	𩚑	6C39
EBF4	𩚑	949F
EBF7	𩚑	8827
EBF8	𩚑	88F5
EBFC	𩚑	6EB8
EBFF	𩚑	39A4
EC00	𩚑	36B9
EC01	𩚑	**
EC02	𩚑	**
EC03	𩚑	453F
EC04	𩚑	66B6
EC07	𩚑	8943
EC0A	𩚑	56D6
EC0B	𩚑	40DF

EC0D	𩚑	39A1
EC11	𩚑	71AD
EC12	𩚑	8366
EC15	𩚑	**
EC16	𩚑	4CB7
EC1E	𩚑	7B43
EC1F	𩚑	797E
EC21	𩚑	6FB5
EC23	𩚑	6A03
EC25	𩚑	53A2
EC27	𩚑	93BF
EC28	𩚑	6836
EC29	𩚑	975D
EC30	𩚑	5D85
EC33	𩚑	5715
EC34	𩚑	9823
EC36	𩚑	5DAB
EC38	𩚑	65BE
EC39	𩚑	69D5
EC3A	𩚑	53D2
EC3D	𩚑	3C11
EC3E	𩚑	6736
EC4A	𩚑	35CA
EC4D	𩚑	48FA
EC4E	𩚑	63E6
EC50	𩚑	7808
EC51	𩚑	9255
EC53	𩚑	43F2
EC55	𩚑	43DF
EC59	𩚑	59F8
EC5B	𩚑	**
EC5E	𩚑	**
EC61	𩚑	3DF7
EC64	𩚑	8FD0
EC65	𩚑	728F
EC66	𩚑	568B
EC74	𩚑	7E9F
EC77	𩚑	4CA4
EC78	𩚑	9547
EC7A	𩚑	71A2

EC7C	𩺰	4D91
EC7D	逡	9012
EC7F	𩺰	4D9C
EC81	达	8FB E
EC82	𩺰	55C1
EC83	𩺰	8FBA
EC85	𩺰	8FB9
EC87	𩺰	4509
EC88	𩺰	7E7F
EC89	𩺰	6F56
EC8A	𩺰	6AB1
EC8B	𩺰	4EEA
EC8C	𩺰	34E4
EC8F	𩺰	373A
EC90	𩺰	8E80
EC97	𩺰	3DEB
EC9C	𩺰	4E9A
EC9F	𩺰	56BF
ECA1	𩺰	8E0E
ECA2	𩺰	5B6D
ECA5	𩺰	63DE
ECA6	𩺰	**
ECA9	𩺰	6530
ECAA	𩺰	562D
ECAC	𩺰	541A
ECAE	𩺰	3DC6
ECB0	𩺰	4C7D
ECB1	𩺰	5622
ECB2	𩺰	561E
ECB3	𩺰	7F49
ECB5	𩺰	5975
ECB7	𩺰	8770
ECB8	𩺰	4E1C
ECBC	𩺰	8117
ECBD	𩺰	9D5E
ECBE	𩺰	8D18
ECBF	𩺰	763B
ECC0	𩺰	9C45
ECC1	𩺰	764E
ECC2	𩺰	77B9

ECC3	𩺰	9345
ECC4	𩺰	5432
ECC5	𩺰	8148
ECC6	𩺰	82F7
ECC7	𩺰	5625
ECC8	𩺰	8132
ECC9	𩺰	8418
ECCA	𩺰	80BD
ECCB	𩺰	55EA
ECCC	𩺰	7962
ECCD	𩺰	5643
ECCE	𩺰	5416
ECD0	𩺰	35CE
ECD1	𩺰	5605
ECD2	𩺰	55F1
ECD3	𩺰	66F1
ECD5	𩺰	362D
ECD6	𩺰	7534
ECD7	𩺰	55F0
ECD8	𩺰	55BA
ECD9	𩺰	5497
ECDA	𩺰	5572
ECDD	𩺰	5ED0
ECE2	𩺰	9EAB
ECE3	𩺰	7D5A
ECE4	𩺰	55DE
ECE6	𩺰	629D
ECE7	𩺰	976D
ECE8	𩺰	5494
ECE9	𩺰	8CCD
ECEA	𩺰	71F6
ECEB	𩺰	9176
ECEC	𩺰	63FC
ECED	𩺰	63B9
ECEE	𩺰	63FE
ECEF	𩺰	5569
ECF1	𩺰	9C72
ECF3	𩺰	519A
ECF4	𩺰	34DF
ECF6	𩺰	51A7

ECF7	𩺰	544D
ECF8	𩺰	551E
ECF9	𩺰	5513
ECFA	𩺰	7666
ECFB	𩺰	8E2D
ECFD	𩺰	75B1
ECFE	𩺰	80B6
ECFF	𩺰	8804
ED00	𩺰	8786
ED01	𩺰	88C7
ED02	𩺰	81B6
ED03	𩺰	841C
ED05	𩺰	44EC
ED06	𩺰	7304
ED08	𩺰	5B90
ED09	𩺰	830B
ED0B	𩺰	567B
ED12	𩺰	9170
ED14	𩺰	9208
ED19	𩺰	7266
ED1B	𩺰	474E
ED1F	𩺰	40FA
ED20	𩺰	9C5D
ED21	𩺰	651F
ED23	𩺰	48F3
ED28	𩺰	**
ED2B	𩺰	##
ED2E	𩺰	71A3
ED2F	𩺰	7E8E
ED30	𩺰	9D50
ED31	𩺰	4E1A
ED32	𩺰	4E04
ED33	𩺰	3577
ED34	𩺰	5B0D
ED35	𩺰	6CB2
ED36	𩺰	5367
ED37	𩺰	36AC
ED38	𩺰	39DC
ED39	𩺰	537D
ED3A	𩺰	36A5

ED3C	𩺰	589A
ED3E	𩺰	822D
ED3F	𩺰	544B
ED40	𩺰	57AA
ED43	𩺰	##
ED44	𩺰	3A52
ED46	𩺰	7374
ED48	𩺰	4D09
ED49	𩺰	9BED
ED4C	𩺰	4C5B
ED50	𩺰	845C
ED55	𩺰	632E
ED56	𩺰	7D25
ED59	𩺰	3A2A
ED5A	𩺰	9008
ED5B	𩺰	52CC
ED5C	𩺰	3E74
ED5D	𩺰	367A
ED5E	𩺰	45E9
ED60	𩺰	7640
ED61	𩺰	5AF0
ED63	𩺰	787A
ED64	𩺰	47B6
ED65	𩺰	58A7
ED66	𩺰	40BF
ED67	𩺰	567C
ED68	𩺰	9B8B
ED69	𩺰	5D74
ED6A	𩺰	7654
ED6C	𩺰	9E85
ED6D	𩺰	4CE1
ED6E	𩺰	**
ED6F	𩺰	37FB
ED70	𩺰	6119
ED73	𩺰	##
ED74	𩺰	565D
ED76	𩺰	57A7
ED79	𩺰	5234
ED7B	𩺰	35AD
ED7C	𩺰	**

ED7D	鵠	9D7C
ED7E	籤	7C56
ED7F	鶯	9B39
ED80	垞	57DE
ED82	肩	5C53
ED83	摑	64D3
ED87	蛄	86AD
ED8C	纏	##
ED8D	函	51FE
ED8F	蔚	5D8E
ED90	霽	9703
ED92	龐	9E81
ED93	遄	904C
ED94	箴	7B1F
ED95	鬢	9B02
ED96	峯	5CD1
ED97	箭	7BA3
ED98	扞	6268
ED99	拚	6335
ED9A	髻	9AFF
ED9B	箴	7BCF
ED9C	鬪	9B2A
ED9D	初	7C7E
ED9E	鬪	**
ED9F	篩	7C42
EDA0	紗	7C86
EDA1	緞	9C15
EDA2	筍	7BFC
EDA3	髮	9B09
EDA4	叢	**
EDA5	鯧	9C1B
EDA7	鮪	9F5A
EDA8	噍	5573
EDA9	冤	5BC3
EDAA	倣	4FFD
EDAB	譽	9E98
EDAC	劬	4FF2
EDAD	剝	5260
EDAE	燎	3E06
EDAF	勑	52D1

EDB0	垢	5767
EDB1	偕	5056
EDB2	姝	59B7
EDB3	袋	5E12
EDB4	鞮	97C8
EDB5	鶉	9DAB
EDB6	轎	8F5C
EDB7	咏	5469
EDB8	鞴	97B4
EDB9	餡	9940
EDBA	鞮	97BA
EDBB	匱	532C
EDBC	悞	6130
EDBD	植	692C
EDBE	段	53DA
EDBF	鯨	9C0A
EDC0	鳩	9D02
EDC1	斂	4C3B
EDC2	陔	9641
EDC3	楮	6980
EDC4	偁	50A6
EDC5	畝	7546
EDC7	駛	99DA
EDC8	剖	5273
EDC9	唸	##
EDCA	斟	9159
EDCB	隄	9681
EDCC	醜	915C
EDCD	醜	##
EDCE	酏	9151
EDD0	棲	637F
EDD2	欄	6ACA
EDD3	噤	5611
EDD4	醜	918E
EDD5	量	757A
EDD6	拘	6285
EDD8	猥	734F
EDD9	變	7C70
EDDC	薛	##
EDDE	盖	76D6

EDDF	養	9B9D
EDE0	个	4E2A
EDE2	莽	83BE
EDE3	峒	8842
EDE4	季	##
EDE5	屈	5C4A
EDE6	稟	69C0
EDE7	僭	**
EDE8	垞	577A
EDE9	劄	521F
EDEA	卮	5DF5
EDEB	从	4ECE
EDEC	氲	6C31
EDEE	但	4F39
EDEF	咤	549C
EDF0	噪	54DA
EDF1	鬪	529A
EDF2	趁	8D82
EDF3	嘯	35FE
EDF4	弋	**
EDF5	塔	35F3
EDF6	膺	##
EDF7	敵	6B52
EDF8	醜	917C
EDF9	顛	9FA5
EDFA	鮫	9B97
EDFB	頰	982E
EDFC	颯	98B4
EDFD	骷	9ABA
EDFE	鈔	9EA8
EDFF	籊	9E84
EE00	煨	717A
EE01	笔	7B14
EE02	濬	##
EE03	瑜	6BFA
EE04	蠟	8818
EE05	罰	7F78
EE06	罰	##
EE07	嘎	5620
EE09	蹙	8E77

EE0A	亂	9F53
EE0B	鉅	##
EE0C	跼	8DD4
EE0D	蹙	8E4F
EE0E	鸛	9E1C
EE0F	踉	8E01
EE10	狂	6282
EE12	蹤	8E28
EE13	蹙	8E75
EE14	蚝	7AD3
EE16	稟	7A3E
EE17	磻	78D8
EE18	泪	6CEA
EE19	簪	8A67
EE1A	瘡	7607
EE1C	韶	9F26
EE1D	汜	6CCE
EE1E	蜥	87D6
EE1F	疝	75C3
EE21	砗	7853
EE23	賤	8D0C
EE24	猪	72E2
EE25	獮	7371
EE26	謗	8B2D
EE27	猥	7302
EE28	髓	74F1
EE29	賣	8CEB
EE2B	蓋	862F
EE2C	德	5FBA
EE2D	裴	88A0
EE2E	苦	44B7
EE2F	袂	##
EE32	熾	##
EE33	詢	8A7E
EE35	悉	##
EE36	惛	60FD
EE37	癩	7667
EE38	髓	9AD7
EE39	鷄	9D44
EE3A	鑰	936E

EE3B	鮭	9B8F
EE3C	蝸	87F5
EE3D	癩	##
EE3E	鱗	**
EE3F	賈	8CF7
EE40	狷	732C
EE41	霰	9721
EE42	鮑	9BB0
EE43	滔	35D6
EE44	豺	72B2
EE45	髻	4C07
EE46	簞	7C51
EE47	齧	994A
EE49	慙	6159
EE4A	鬚	4C04
EE4B	麋	9E96
EE4C	憾	617D
EE4D	𤝵	##
EE4E	坟	575F
EE4F	傷	616F
EE50	柄	62A6
EE51	𤝵	6239
EE52	拾	**
EE53	搯	3A5C
EE54	慚	61E2
EE55	廛	53AA
EE57	搥	6364
EE58	拇	6802
EE59	唳	35D2
EE5A	歲	5D57
EE5C	迥	8FDA
EE5E	嗽	##
EE5F	僮	50D9
EE61	礮	7906
EE62	匱	5332
EE63	隄	9638
EE65	睽	4065
EE66	譽	##
EE67	矾	77FE
EE68	糲	##

EE69	糲	7CC2
EE6B	糲	7CDA
EE6C	稽	7A2D
EE6D	聰	8066
EE6E	睨	8063
EE6F	紕	7D4D
EE70	暈	7505
EE71	𤝵	74F2
EE72	覓	8994
EE73	檐	821A
EE74	盼	670C
EE75	睨	8062
EE77	睥	805B
EE78	𤝵	74F0
EE79	𤝵	8103
EE7A	𤝵	7724
EE7B	羈	8989
EE7D	𤝵	7553
EE7F	𤝵	87A9
EE80	𤝵	87CE
EE81	𤝵	81C8
EE82	𤝵	878C
EE83	𤝵	8A49
EE84	𤝵	8CAD
EE85	𤝵	8B43
EE86	𤝵	772B
EE87	𤝵	74F8
EE88	𤝵	84DA
EE89	𤝵	3635
EE8A	𤝵	69B2
EE8B	𤝵	8DA6
EE8C	𤝵	##
EE8D	𤝵	89A9
EE8E	𤝵	**
EE8F	𤝵	6DB9
EE90	𤝵	87C1
EE92	𤝵	74E7
EE93	𤝵	3DDB
EE94	𤝵	7176
EE95	𤝵	60A4

EE96	懣	619C
EE97	漚	3CD1
EE98	甞	**
EE99	恁	6077
EE9A	懣	##
EE9B	𤝵	7F71
EE9D	𤝵	**
EE9E	懲	60E9
EE9F	馱	4B7E
EEA0	刪	5220
EEAB	峇	5CC1
EEB2	𤝵	4562
EEB3	𤝵	5B1F
EEB5	齊	9F50
EEB6	麥	9EA6
F319	Ā	0100
F31A	Á	00C1
F31B	Ă	01CD
F31C	Ä	00C0
F31D	Ē	0112
F31E	É	00C9
F31F	Ë	011A
F320	È	00C8
F321	Ī	014C
F322	Ī	00D3
F323	Ï	01D1
F324	Ï	00D2
F326	Ê	1EBE
F328	Ë	1EC0
F329	Ê	00CA
F32A	ā	0101
F32B	ǎ	00E1
F32C	ǎ	01CE
F32D	ǎ	00E0
F32E	ɑ	0251
F32F	ē	0113
F330	é	00E9
F331	ě	011B
F332	è	00E8
F333	ī	012B

F334	í	00ED
F335	ĩ	01D0
F336	ì	00EC
F337	ō	014D
F338	ó	00F3
F339	ǒ	01D2
F33A	ò	00F2
F33B	ū	016B
F33C	ú	00FA
F33D	ũ	01D4
F33E	ù	00F9
F33F	û	01D6
F340	ű	01D8
F341	ü	01DA
F342	ü	01DC
F343	ü	00FC
F345	é	1EBF
F347	è	1EC1
F348	ê	00EA
F349	g	0261
F3A3	攪	650A
F3A6	𤝵	4E3D
F3A7	𤝵	6EDD
F3A8	𤝵	9D4E
F3A9	𤝵	91DF
F3AD	撐	6491
F3AE	会	4F1A
F3AF	徇	4F28
F3B0	𤝵	4FA8
F3B1	𤝵	5156
F3B2	兴	5174
F3B3	衣	519C
F3B4	凤	51E4
F3B5	𤝵	52A1
F3B6	𤝵	52A8
F3B7	医	533B
F3B8	华	534E
F3B9	发	53D1
F3BA	变	53D8
F3BB	团	56E2

F3BC	声	58F0
F3BD	处	5904
F3BE	备	5907
F3BF	夆	5932
F3C0	头	5934
F3C1	学	5B66
F3C2	实	5B9E
F3C3	美	5B9F
F3C4	岚	5C9A
F3C5	庆	5E86
F3C6	总	603B
F3C7	齐	6589
F3C8	桎	67FE
F3C9	采	6804
F3CA	桥	6865
F3CB	济	6D4E
F3CC	炼	70BC
F3CD	电	7535
F3CE	纤	7EA4
F3CF	纬	7EAC
F3D0	纺	7EBA
F3D1	织	7EC7
F3D2	经	7ECF
F3D3	统	7EDF
F3D4	缆	7F06
F3D5	卸	7F37
F3D6	艺	827A
F3D7	苏	82CF
F3D8	药	836F
F3D9	视	89C6
F3DA	设	8BBE
F3DB	询	8BE2
F3DC	车	8F66
F3DD	轧	8F67
F3DE	轮	8F6E
F3DF	瑄	7411
F3E0	幼	7CFC
F3E1	緡	7DCD
F3E2	櫻	6946
F3E3	寵	7AC9

F3E4	劫	5227
F3E9	醜	918C
F3EA	颯	78B8
F3EB	猷	915E
F3EC	胼	80BC
F3EE	贗	8D0B
F3EF	肢	80F6
F3F3	肱	809F
F3F4	黏	9EC7
F3F5	鳩	4CCD
F3F6	鷓	9DC9
F3F7	鷲	9E0C
F3F8	鯢	4C3E
F3FB	鸛	9E0A
F3FD	嚶	35C1
F3FF	浴	6E9A
F400	晒	823E
F401	貳	7519
F403	醜	4911
F404	马	9A6C
F405	骏	9A8F
F406	龙	9F99
F407	褚	7987
F40C	两	4E24
F40D	乾	4E81
F40E	龜	4E80
F40F	尔	4E87
F410	亿	4EBF
F411	佻	4EEB
F412	佻	4F37
F413	佻	344C
F414	俾	4FBD
F415	犖	3E48
F416	僦	5003
F417	僦	5088
F418	僦	347D
F419	僦	3493
F41A	僦	34A5
F41B	卅	5186
F41C	牵	5905

F41D	凜	51DB
F41E	函	51FC
F41F	刃	5205
F420	争	4E89
F421	剗	5279
F422	剗	5290
F423	医	5327
F424	暇	35C7
F425	厥	53A9
F426	厨	3551
F427	廠	53B0
F428	屨	3553
F429	参	53C2
F42A	心	5423
F42B	吠	356D
F42C	味	3572
F42D	饒	3681
F42E	嘸	5493
F42F	咣	54A3
F430	恢	54B4
F431	咳	54B9
F432	喏	54D0
F433	喏	54EF
F434	啓	5518
F435	唵	5523
F436	啮	5528
F437	嘖	3598
F438	嚙	553F
F439	囙	35A5
F43A	哪	35BF
F43B	嚙	55D7
F43C	啁	35C5
F43E	吟	5525
F443	啁	5590
F445	孳	39EC
F447	蹶	8E46
F44A	瞶	4053
F44C	睽	777A
F44E	攬	3A34
F44F	跂	47D5

F453	攪	64DD
F458	攪	648D
F459	躑	8E7E
F464	蹶	47F4
F467	匏	9AB2
F468	擗	3A67
F46A	敝	3FED
F46B	擗	3506
F470	鸛	9D6E
F471	頤	9815
F473	眈	43D9
F475	擗	64B4
F476	啞	54E3
F47A	掾	39FB
F47F	擊	64EA
F482	蹶	8E68
F487	蹶	480B
F489	黻	3FFA
F48A	墜	5873
F492	啞	5579
F493	磔	40BB
F494	瞞	43BA
F496	頤	4AB4
F499	臍	81AA
F49A	詐	98F5
F49C	擗	6379
F49D	摠	39FE
F49F	踟	8DC0
F4A0	嚙	56A1
F4A1	擗	647C
F4A2	羣	3E43
F4AB	懼	3992
F4AC	淋	3A06
F4AE	啞	3578
F4B1	嚙	5652
F4B5	藹	34BC
F4B6	余	6C3D
F4C2	羣	7F93
F4C6	嚙	35FB
F4CB	瘡	3F93

F4D6	𩺰	3FF9
F4D8	𩺲	6432
F4E1	搯	3A18
F4EA	𩺶	95AA
F4EB	𩺷	54CC
F4EC	𩺸	82C4
F4ED	𩺹	55B9
F4F0	𩺻	9C26
F4F1	𩺼	9AB6
F4F4	𩺽	7140
F4F5	𩺾	816D
F4F6	𩺿	80EC
F4F7	𩻀	5C1C
F4F9	𩻁	8134
F4FA	𩻂	3797
F4FB	𩻃	535F
F4FD	𩻄	91B6
F502	𩻅	35DD
F504	𩻆	3609
F506	𩻇	56AF
F512	𩻈	5A54
F517	𩻉	579C
F51E	𩻊	3703
F527	𩻋	5899
F528	𩻌	5268
F529	𩻍	361A
F52B	𩻎	7BB2
F52C	𩻏	5B68
F52D	𩻐	4800
F52E	𩻑	4B2C
F52F	𩻒	9F27
F530	𩻓	49E7
F531	𩻔	9C1F
F532	𩻕	9B8D
F535	𩻖	55FB
F536	𩻗	35F2
F537	𩻘	5689
F538	𩻙	4E28
F539	𩻚	5902
F53C	𩻛	9751

F53E	𩻜	4E5B
F53F	𩻝	4EBB
F540	𩻞	353E
F541	𩻟	5C23
F542	𩻠	5F51
F543	𩻡	5FC4
F544	𩻢	38FA
F545	𩻣	624C
F546	𩻤	6535
F547	𩻥	6B7A
F548	𩻦	6C35
F549	𩻧	6C3A
F54A	𩻨	706C
F54B	𩻩	722B
F54C	𩻪	4E2C
F54D	𩻫	72AD
F54F	𩻬	7F52
F550	𩻭	793B
F551	𩻮	7CF9
F552	𩻯	7F53
F554	𩻰	34C1
F557	𩻱	8002
F558	𩻲	8080
F55B	𩻳	535D
F55C	𩻴	8864
F55D	𩻵	89C1
F55F	𩻶	8BA0
F560	𩻷	8D1D
F561	𩻸	9485
F562	𩻹	9578
F563	𩻺	957F
F564	𩻻	95E8
F566	𩻼	97E6
F567	𩻽	9875
F568	𩻾	98CE
F569	𩻿	98DE
F56A	𩼀	9963
F56C	𩼁	9C7C
F56D	𩼂	9E1F
F56E	𩼃	9EC4

F56F	𩼄	6B6F
F570	𩼅	9F9C
F571	𩼆	4E37
F573	𩼇	961D
F574	𩼈	6237
F575	𩼉	94A2
F634	𩼊	5D3E
F635	𩼋	5D48
F636	𩼌	5D56
F637	𩼍	3DFC
F638	𩼎	380F
F639	𩼏	5DA4
F63A	𩼐	5DB9
F63B	𩼑	3820
F63C	𩼒	3838
F63D	𩼓	5E42
F63E	𩼔	5EBD
F63F	𩼕	5F25
F640	𩼖	5F83
F641	𩼗	3908
F642	𩼘	3914
F643	𩼙	393F
F644	𩼚	394D
F645	𩼛	60D7
F646	𩼜	613D
F647	𩼝	5CE5
F648	𩼞	3989
F649	𩼟	61B7
F64A	𩼠	61B9
F64B	𩼡	61CF
F64C	𩼢	39B8
F64D	𩼣	622C
F64E	𩼤	6290
F64F	𩼥	62E5
F650	𩼦	6318
F651	𩼧	39F8
F652	𩼨	56B1
F653	𩼩	3A03
F654	𩼪	63E2
F655	𩼫	63FB

F656	𩼬	6407
F657	𩼭	645A
F658	𩼮	3A4B
F659	𩼯	64C0
F65A	𩼰	5D15
F65B	𩼱	5621
F65C	𩼲	9F9F
F65D	𩼳	3A97
F65E	𩼴	6586
F65F	𩼵	3ABD
F660	𩼶	65FF
F661	𩼷	6653
F662	𩼸	3AF2
F663	𩼹	6692
F664	𩼺	3B22
F665	𩼻	6716
F666	𩼼	3B42
F667	𩼽	67A4
F668	𩼾	6800
F669	𩼿	3B58
F66A	𩽀	684A
F66B	𩽁	6884
F66C	𩽂	3B72
F66D	𩽃	3B71
F66E	𩽄	3B7B
F66F	𩽅	6909
F670	𩽆	6943
F671	𩽇	725C
F672	𩽈	6964
F673	𩽉	699F
F674	𩽊	6985
F675	𩽋	3BBC
F676	𩽌	69D6
F677	𩽍	3BDD
F678	𩽎	6A65
F679	𩽏	6A74
F67A	𩽐	6A71
F67B	𩽑	6A82
F67C	𩽒	3BEC
F67D	𩽓	6A99

F67E	櫟	3BF2
F67F	櫟	6AAB
F680	櫟	6AB5
F681	櫟	6AD4
F682	櫟	6AF6
F683	歿	6B81
F684	毀	6BC1
F685	稔	6BEA
F686	沔	6C75
F687	沪	6CAA
F688	沂	3CCB
F689	沕	6D02
F68A	沕	6D06
F68B	沕	6D26
F68C	沕	6D81
F68D	沕	3CEF
F68E	沕	6DA4
F68F	沕	6DB1
F690	沕	6E15
F691	沕	6E18
F692	温	6E29
F693	灑	6E86
F695	灑	6EBB
F696	滢	6EE2
F697	滢	6EDA
F698	齿	9F7F
F699	滨	6EE8
F69A	滩	6EE9
F69B	濛	6F24
F69C	濛	6F34
F69D	濛	3D46
F69F	濛	6F81
F6A0	濛	6FBE
F6A1	濛	3D6A
F6A2	濛	3D75
F6A3	增	71B7
F6A4	吞	5C99
F6A5	瀨	3D8A
F6A6	瀨	702C
F6A7	瀨	3D91

F6A8	澄	7050
F6A9	灑	7054
F6AA	灯	706F
F6AB	灿	707F
F6AC	炉	7089
F6AE	睥	43C1
F6AF	噤	35F1
F6B1	①	2460
F6B2	②	2461
F6B3	③	2462
F6B4	④	2463
F6B5	⑤	2464
F6B6	⑥	2465
F6B7	⑦	2466
F6B8	⑧	2467
F6B9	⑨	2468
F6BA	⑩	2469
F6BB	(1)	2474
F6BC	(2)	2475
F6BD	(3)	2476
F6BE	(4)	2477
F6BF	(5)	2478
F6C0	(6)	2479
F6C1	(7)	247A
F6C2	(8)	247B
F6C3	(9)	247C
F6C4	(10)	247D
F6C5	i	2170
F6C6	ii	2171
F6C7	iii	2172
F6C8	iv	2173
F6C9	v	2174
F6CA	vi	2175
F6CB	vii	2176
F6CC	viii	2177
F6CD	ix	2178
F6CE	x	2179
F6CF	\	4E36
F6D0	J	4E3F
F6D1	J	4E85

F6D2	一	4EA0
F6D3	冂	5182
F6D4	一	5196
F6D5	彳	51AB
F6D6	勺	52F9
F6D7	匚	5338
F6D8	冂	5369
F6D9	厶	53B6
F6DA	女	590A
F6DB	宀	5B80
F6DC	ㄩ	5DDB
F6DD	么	2F33
F6DE	广	5E7F
F6E0	厶	5F50
F6E1	彳	5F61
F6E2	支	6534
F6E4	广	7592
F6E6	彳	8FB5
F6E8	〃	00A8
F6E9	^	02C6
F6EA	\	30FD
F6EB	彳	30FE
F6EC	\	309D
F6ED	彳	309E
F6F0	々	3005
F6F1	彳	3006
F6F2	〇	3007
F6F3	一	30FC
F6F4	[FF3B
F6F5]	FF3D
F6F6	*	273D
F6F7	あ	3041
F6F8	あ	3042
F6F9	い	3043
F6FA	い	3044
F6FB	う	3045
F6FC	う	3046
F6FD	え	3047
F6FE	え	3048
F6FF	お	3049

F700	お	304A
F701	か	304B
F702	が	304C
F703	き	304D
F704	ぎ	304E
F705	く	304F
F706	ぐ	3050
F707	け	3051
F708	げ	3052
F709	こ	3053
F70A	ご	3054
F70B	さ	3055
F70C	ざ	3056
F70D	し	3057
F70E	じ	3058
F70F	ず	3059
F710	ず	305A
F711	せ	305B
F712	ぜ	305C
F713	そ	305D
F714	ぞ	305E
F715	た	305F
F716	だ	3060
F717	ち	3061
F718	ぢ	3062
F719	っ	3063
F71A	っ	3064
F71B	づ	3065
F71C	て	3066
F71D	で	3067
F71E	と	3068
F71F	ど	3069
F720	な	306A
F721	に	306B
F722	ぬ	306C
F723	ね	306D
F724	の	306E
F725	は	306F
F726	ば	3070
F727	ば	3071

F728	ひ	3072
F729	び	3073
F72A	び	3074
F72B	ふ	3075
F72C	ぶ	3076
F72D	ぶ	3077
F72E	へ	3078
F72F	べ	3079
F730	ぺ	307A
F731	ほ	307B
F732	ほ	307C
F733	ほ	307D
F734	ま	307E
F735	み	307F
F736	む	3080
F737	め	3081
F738	も	3082
F739	や	3083
F73A	や	3084
F73B	ゆ	3085
F73C	ゆ	3086
F73D	よ	3087
F73E	よ	3088
F73F	ら	3089
F740	り	308A
F741	る	308B
F742	れ	308C
F743	ろ	308D
F744	わ	308E
F745	わ	308F
F746	ゐ	3090
F747	ゑ	3091
F748	を	3092
F749	ん	3093
F74A	ア	30A1
F74B	ア	30A2
F74C	イ	30A3
F74D	イ	30A4
F74E	ウ	30A5
F74F	ウ	30A6

F750	エ	30A7
F751	エ	30A8
F752	オ	30A9
F753	オ	30AA
F754	カ	30AB
F755	ガ	30AC
F756	キ	30AD
F757	ギ	30AE
F758	ク	30AF
F759	グ	30B0
F75A	ケ	30B1
F75B	ゲ	30B2
F75C	コ	30B3
F75D	ゴ	30B4
F75E	サ	30B5
F75F	ザ	30B6
F760	シ	30B7
F761	ジ	30B8
F762	ス	30B9
F763	ズ	30BA
F764	セ	30BB
F765	ゼ	30BC
F766	ソ	30BD
F767	ゾ	30BE
F768	タ	30BF
F769	ダ	30C0
F76A	チ	30C1
F76B	ヂ	30C2
F76C	ツ	30C3
F76D	ツ	30C4
F76E	ヅ	30C5
F76F	テ	30C6
F770	デ	30C7
F771	ト	30C8
F772	ド	30C9
F773	ナ	30CA
F774	ニ	30CB
F775	ヌ	30CC
F776	ネ	30CD
F777	ノ	30CE

F778	ハ	30CF
F779	バ	30D0
F77A	バ	30D1
F77B	ヒ	30D2
F77C	ビ	30D3
F77D	ピ	30D4
F77E	フ	30D5
F77F	ブ	30D6
F780	ブ	30D7
F781	ヘ	30D8
F782	ベ	30D9
F783	ペ	30DA
F784	ホ	30DB
F785	ボ	30DC
F786	ボ	30DD
F787	マ	30DE
F788	ミ	30DF
F789	ム	30E0
F78A	メ	30E1
F78B	モ	30E2
F78C	ヤ	30E3
F78D	ヤ	30E4
F78E	ユ	30E5
F78F	ユ	30E6
F790	ヨ	30E7
F791	ヨ	30E8
F792	ラ	30E9
F793	リ	30EA
F794	ル	30EB
F795	レ	30EC
F796	ロ	30ED
F797	ワ	30EE
F798	ワ	30EF
F799	ヰ	30F0
F79A	エ	30F1
F79B	ヲ	30F2
F79C	ン	30F3
F79D	ヴ	30F4
F79E	カ	30F5
F79F	ケ	30F6

F7A0	A	0410
F7A1	B	0411
F7A2	B	0412
F7A3	Г	0413
F7A4	Д	0414
F7A5	E	0415
F7A6	È	0401
F7A7	Ж	0416
F7A8	З	0417
F7A9	И	0418
F7AA	Й	0419
F7AB	К	041A
F7AC	Л	041B
F7AD	M	041C
F7AE	H	041D
F7AF	О	041E
F7B0	П	041F
F7B1	P	0420
F7B2	C	0421
F7B3	T	0422
F7B4	У	0423
F7B5	Ф	0424
F7B6	X	0425
F7B7	Ц	0426
F7B8	Ч	0427
F7B9	Ш	0428
F7BA	Щ	0429
F7BB	Ъ	042A
F7BC	Ы	042B
F7BD	Ь	042C
F7BE	Э	042D
F7BF	Ю	042E
F7C0	Я	042F
F7C1	a	0430
F7C2	б	0431
F7C3	в	0432
F7C4	г	0433
F7C5	д	0434
F7C6	e	0435
F7C7	ë	0451

F7C8	ж	0436
F7C9	з	0437
F7CA	и	0438
F7CB	й	0439
F7CC	к	043A
F7CD	л	043B
F7CE	м	043C
F7CF	н	043D
F7D0	о	043E
F7D1	п	043F
F7D2	р	0440
F7D3	с	0441
F7D4	т	0442
F7D5	у	0443
F7D6	ф	0444
F7D7	х	0445
F7D8	ц	0446
F7D9	ч	0447
F7DA	ш	0448
F7DB	щ	0449

F7DC	ъ	044A
F7DD	ы	044B
F7DE	ь	044C
F7DF	э	044D
F7E0	ю	044E
F7E1	я	044F
F7E2	†	21E7
F7E3	↖	21B8
F7E4	↔	21B9
F7E7	ℓ	4E5A
F7E9	ℓ	5202
F7EC	☒	5188
F817	¬	FFE2
F818	¡	FFE4
F819	'	FF07
F81A	”	FF02
F81B	株	3231
F81C	No.	2116
F81D	Tel	2121
F81E	ˆ	309B

F81F	ˆ	309C
F820	ˆ	2E80
F821	↵	2E84
F822	∟	2E86
F823	∟	2E87
F824	↘	2E88
F825	†	2E8A
F826	ˆ	2E8C
F827	ˆ	2E8D
F828	≡	2E95
F829	≡	2E9C
F82A	月	2E9D
F82B	ˆ	2EA5
F82C	ˆ	2EA7
F82D	ˆ	2EAA
F82E	ˆ	2EAC
F82F	ˆ	2EAE
F830	ˆ	2EB6
F831	月	2EBC
F832	ˆ	2EBE

F833	角	2EC6
F834	𠃉	2ECA
F835	𠃉	2ECC
F836	𠃉	2ECD
F837	𠃉	2ECF
F838	𠃉	2ED6
F839	𠃉	2ED7
F83A	𠃉	2EDE
F83B	骨	2EE3
F83F	ƒ	0283
F840	ɸ	0250
F841	ε	025B
F842	ɔ	0254
F843	θ	0275
F844	œ	0153
F845	ø	00F8
F846	η	014B
F847	ϋ	028A
F848	ı	026A

** To maintain backward compatibility, the corresponding PUA code points in ISO 10646 v2.0 of those unified characters will be reserved.

To maintain backward compatibility, the corresponding PUA code points in ISO 10646 v2.0 of those characters not verifiable will be reserved.